

2007 Hummer H3

2007 TRANSMISSION Manual Transmission - Aisin AR5 - H3

2007 TRANSMISSION

Manual Transmission - Aisin AR5 - H3

SPECIFICATIONS

FASTENER TIGHTENING SPECIFICATIONS

Fastener Tightening Specifications

Application	Specification	
	Metric	English
Backup Lamp Switch	44 N.m	32 lb ft
Control Lever Boot Screw	2.5 N.m	22 lb in
Drain Plug	37 N.m	27 lb ft
Fill Plug	37 N.m	27 lb ft
Fuel Hose/Pipe Brackets Nut	20 N.m	15 lb ft
Input Shaft Bearing Retainer Bolt	17 N.m	13 lb ft
Shift Lever Assembly Bolt	20 N.m	15 lb ft
Transmission Mount Bolt	60 N.m	44 lb ft
Transmission Mount Nut	57 N.m	42 lb ft
Transmission Mounting Bolt	50 N.m	37 lb ft
Vehicle Speed Sensor (VSS)	17 N.m	13 lb ft

SEALERS, ADHESIVES AND LUBRICANTS

Sealers, Adhesives and Lubricants

Application	Type of Material	GM Part Number	
		United States	Canada
Input Shaft Bearing Retainer	Sealant	89020326	89021188
Input Shaft Bearing Retainer Bolts	Pipe Sealant	12346004	10953480
Transmission Fluid	75W-90 Gear Oil	89021806	89021807

LUBRICATION SPECIFICATIONS

Lubrication Specifications

Application	Specification	
	Metric	English
Manual Transmission Fluid		

2007 Hummer H3

2007 TRANSMISSION Manual Transmission - Aisin AR5 - H3

API AI-A or GL-3 SAE 75W-90 GM P/N 89021806 (Canadian P/N 89021807)	RWD: 2.2 liters 4WD: 2.3 liters	RWD: 2.3 quarts 4WD: 2.4 quarts
--	------------------------------------	------------------------------------

TRANSMISSION CLEARANCE SPECIFICATIONS

Gear Axial Clearance

Application	Standard Clearance Metric	Maximum Clearance Metric	Standard Clearance English	Maximum Clearance English
1st Gear	0.20-0.45 mm	0.50 mm	0.0079-0.0177 in	0.0197 in
2nd Gear	0.10-0.25 mm	0.30 mm	0.0039-0.00098 in	0.0118 in
3rd Gear	0.10-0.25 mm	0.30 mm	0.0039-0.00098 in	0.0118 in
5th Countershaft Gear	0.10-0.35 mm	0.40 mm	0.0039-0.0138 in	0.0157 in

Gear Radial Clearance

Application	Standard Clearance Metric	Maximum Clearance Metric	Standard Clearance English	Maximum Clearance English
1st Gear	0.020-0.073 mm	0.160 mm	0.0008-0.0029 in	0.0063 in
2nd Gear	0.015-0.068 mm	0.160 mm	0.0006-0.0027 in	0.0063 in
3rd Gear	0.015-0.068 mm	0.160 mm	0.0006-0.0027 in	0.0063 in
5th Countershaft Gear	0.015-0.068 mm	0.160 mm	0.0006-0.0027 in	0.0063 in
Reverse Idler Gear	0.040-0.082 mm	0.130 mm	0.0016-0.0032 in	0.0051 in

Output Shaft

Application	Specification	
	Metric	English
Runout - Maximum	0.06 mm	0.0024 in
Flange Thickness - Minimum	4.70 mm	0.1859 in

Output Shaft Bearing Journals - Minimum Diameter

	Specification	

2007 Hummer H3

2007 TRANSMISSION Manual Transmission - Aisin AR5 - H3

Application	Metric	English
1st Gear	38.860 mm	1.5299 in
2nd Gear	46.860 mm	1.8449 in
3rd Gear	37.860 mm	1.4905 in

Countershaft Bearing Journals - Minimum Diameter

Application	Specification	
	Metric	English
5th Countershaft Gear Bearing	29.86 mm	1.1756 in

Synchronizer Blocker Ring to Gear - Minimum Clearance

Application	Specification	
	Metric	English
1st Gear	0.8 mm	0.031 in
2nd Gear	0.8 mm	0.031 in
3rd Gear	0.8 mm	0.031 in
4th Gear	0.8 mm	0.031 in
5th Gear	0.8 mm	0.031 in

Synchronizer Sleeve to Shift Fork - Maximum Clearance

Application	Specification	
	Metric	English
1st/2nd Gear	1.0 mm	0.039 in
3rd/4th Gear	1.0 mm	0.039 in
5th Gear	1.0 mm	0.039 in
Reverse Idler Gear	0.50 mm	0.0197 in

1ST AND 2ND GEAR SYNCHRONIZER RETAINING RING SPECIFICATIONS**1st and 2nd Gear Synchronizer Retaining Ring Specifications**

Mark	Thickness (mm)	Thickness (in)
A	2.30-2.35	0.0906-0.0925
B	2.35-2.40	0.0925-0.0945
C	2.40-2.45	0.0945-0.0965
D	2.45-2.50	0.0965-0.0984
E	2.50-2.55	0.0984-0.1004

2007 Hummer H3

2007 TRANSMISSION Manual Transmission - Aisin AR5 - H3

F	2.55-2.60	0.1004-0.1024
G	2.60-2.65	0.1024-0.1043

3RD AND 4TH GEAR SYNCHRONIZER RETAINING RING SPECIFICATIONS**3rd and 4th Gear Synchronizer Retaining Ring Specifications**

Mark	Thickness (mm)	Thickness (in)
A	1.80-1.85	0.0709-0.0728
B	1.85-1.90	0.0728-0.0748
C	1.90-1.95	0.0748-0.0768
D	1.95-2.00	0.0768-0.0787
E	2.00-2.05	0.0787-0.0807
F	2.05-2.10	0.0807-0.0827
G	2.10-2.15	0.0827-0.0846

5TH GEAR SYNCHRONIZER RETAINING RING SPECIFICATIONS**5th Gear Synchronizer Retaining Ring Specifications**

Mark	Thickness (mm)	Thickness (in)
A	2.80-2.85	0.1102-0.1122
B	2.85-2.90	0.1122-0.1142
C	2.90-2.95	0.1142-0.1161
D	2.95-3.00	0.1161-0.1181
E	3.00-3.05	0.1181-0.1201
F	3.05-3.10	0.1201-0.1220
G	3.10-3.15	0.1220-0.1240

COUNTERSHAFT FRONT BEARING RETAINING RING SPECIFICATIONS**Countershaft Front Bearing Retaining Ring Specifications**

Mark	Thickness (mm)	Thickness (in)
A	2.05-2.10	0.0807-0.0827
B	2.10-2.15	0.0827-0.0846
C	2.15-2.20	0.0846-0.0866
D	2.20-2.25	0.0866-0.0886
E	2.25-2.30	0.0886-0.0906
F	2.30-2.35	0.0906-0.0925

2007 Hummer H3

2007 TRANSMISSION Manual Transmission - Aisin AR5 - H3

INPUT SHAFT BEARING RETAINING RING SPECIFICATIONS

Input Shaft Bearing Retaining Ring Specifications

Mark	Thickness (mm)	Thickness (in)
A	2.10-2.15	0.0827-0.0846
B	2.15-2.20	0.0846-0.0866
C	2.20-2.25	0.0866-0.0886
D	2.25-2.30	0.0886-0.0906
E	2.30-2.35	0.0906-0.0925
F	2.35-2.40	0.0925-0.0945
G	2.40-2.45	0.0945-0.0965

FIFTH GEAR RETAINING RING SPECIFICATIONS

Fifth Gear Retaining Ring Specifications

Mark	Thickness (mm)	Thickness (in)
C	2.75-2.80	0.1083-0.1102
D	2.80-2.85	0.1102-0.1122
E	2.85-2.90	0.1122-0.1142
F	2.90-2.95	0.1142-0.1161
G	2.95-3.00	0.1161-0.1181
H	3.00-3.05	0.1181-0.1201
J	3.05-3.10	0.1201-0.1220
K	3.10-3.15	0.1220-0.1240
L	3.15-3.20	0.1240-0.1260
M	3.20-3.25	0.1260-0.1280
N	3.25-3.30	0.1280-0.1299
P	3.30-3.35	0.1299-0.1319

COMPONENT RESISTANCE



Component Resistance

Component	Pass Through Pins	Resistance 25° C (77°F)	Resistance 150° C (302°F)	Resistance to Ground (Case)
Vehicle Speed Sensor	1, 2	1,300-1,500 ohms	2,360-3,160 ohms	Greater than 10 M ohms

SCHEMATIC AND ROUTING DIAGRAMS

MANUAL TRANSMISSION SCHEMATIC ICONS

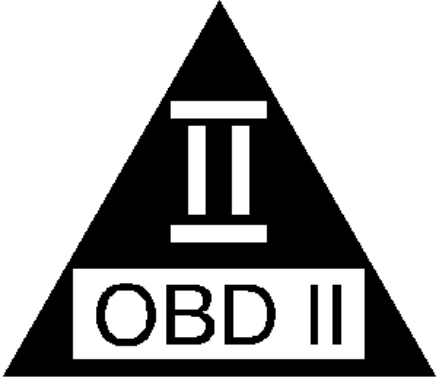
Manual Transmission Schematic Icons

Icon	Icon Definition
	<p>NOTE:</p> <p>The OBD II symbol is used on the circuit diagrams in order to alert the technician that the circuit is essential for proper OBD II emission control circuit operation. Any circuit which fails and causes the malfunction indicator lamp (MIL) to turn ON or causes emissions-related component damage, is identified as an OBD II circuit.</p>
	<p>IMPORTANT:</p> <p>Twisted-pair wires provide an effective "shield" that helps protect sensitive electronic components from electrical interference. If the wires were covered with shielding, install new shielding.</p> <p>In order to prevent electrical interference from degrading the performance of the connected components, you must maintain the proper specification when making any repairs to the twisted-pair wires shown :</p> <ul style="list-style-type: none"> ● The wires must be twisted a minimum of 9 turns per 31 cm (12 in) as measured anywhere along the length of the wires. ● The outside diameter of the twisted wires must not exceed 6.0 mm (.25 in). <p>Refer to <u>Splicing Twisted or Shielded Cable</u> .</p>

MANUAL TRANSMISSION SCHEMATICS

2007 Hummer H3

2007 TRANSMISSION Manual Transmission - Aisin AR5 - H3

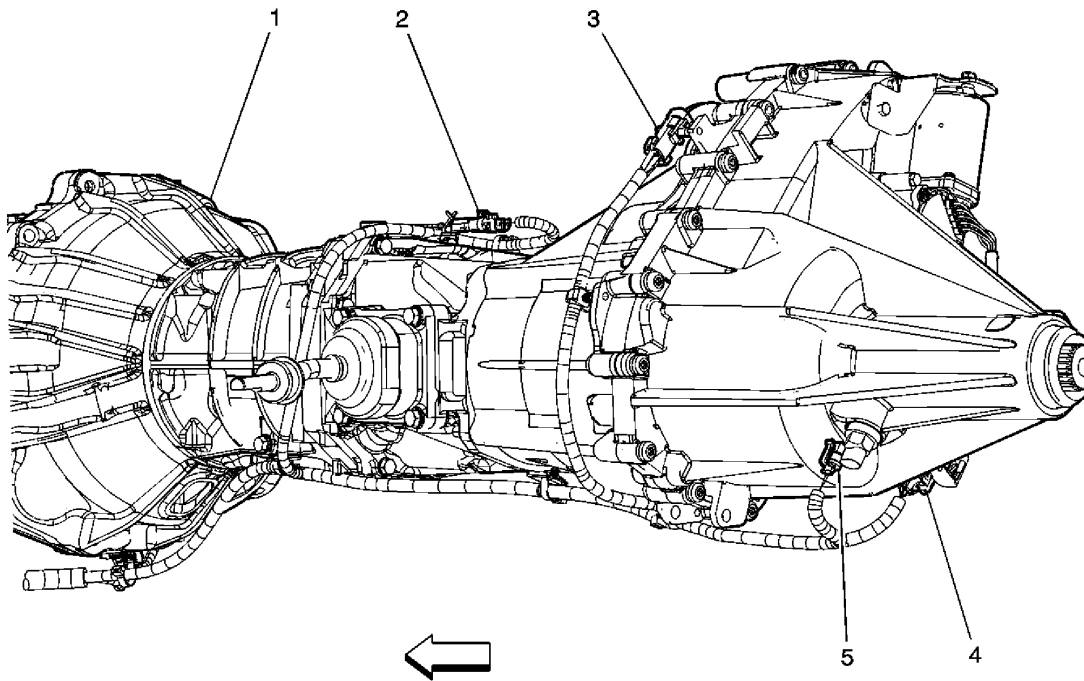

Fig. 2: Identifying Rear Engine Harness (MA5)
Courtesy of GENERAL MOTORS CORP.

Callouts For Fig. 2

Callout	Component Name
1	Transmission Case
2	Backup Lamp Switch
3	Heated Oxygen Sensor (HO2S) 2
4	Transfer Case Encoder Motor Connector
5	Vehicle Speed Sensor (VSS) Connector

MANUAL TRANSMISSION CONNECTOR END VIEWS

Vehicle Speed Sensor (VSS)

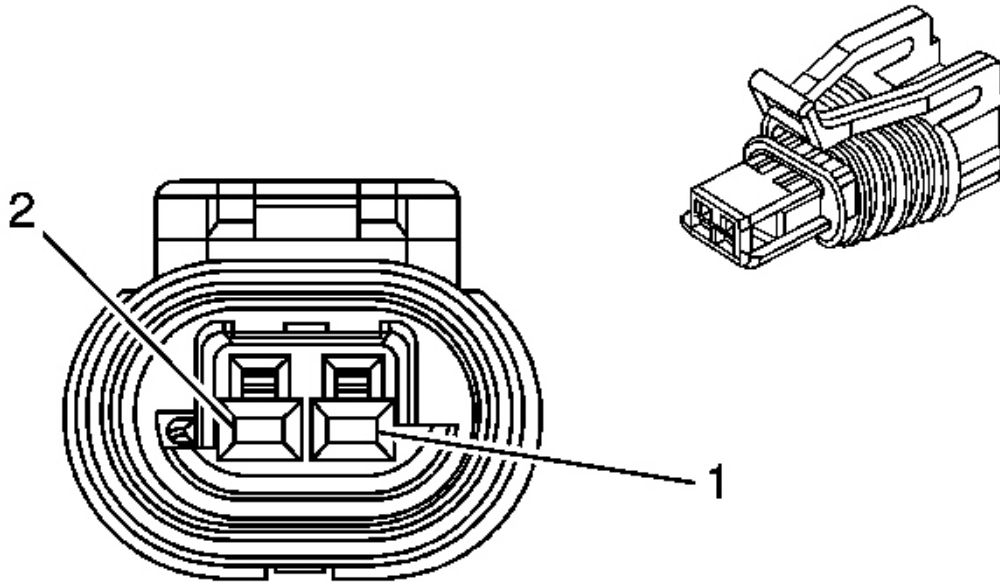

Fig. 3: Vehicle Speed Sensor (VSS) Connector End View
 Courtesy of GENERAL MOTORS CORP.

Vehicle Speed Sensor (VSS) Connector Parts Information

Connector Part Information

- OEM: 15359365
- Service:
- Description: 2-Way F GT 150 Series Sealed (BK)

Terminal Part Information

- Terminal/Tray:
- Core/Insulation Crimp:
- Release Tool/Test Probe:

Vehicle Speed Sensor (VSS) Connector Terminal Identification

Pin	Wire Color	Circuit No.	Function
1	PU	401	VSS Low Signal

VISUAL IDENTIFICATION

DISASSEMBLED VIEWS

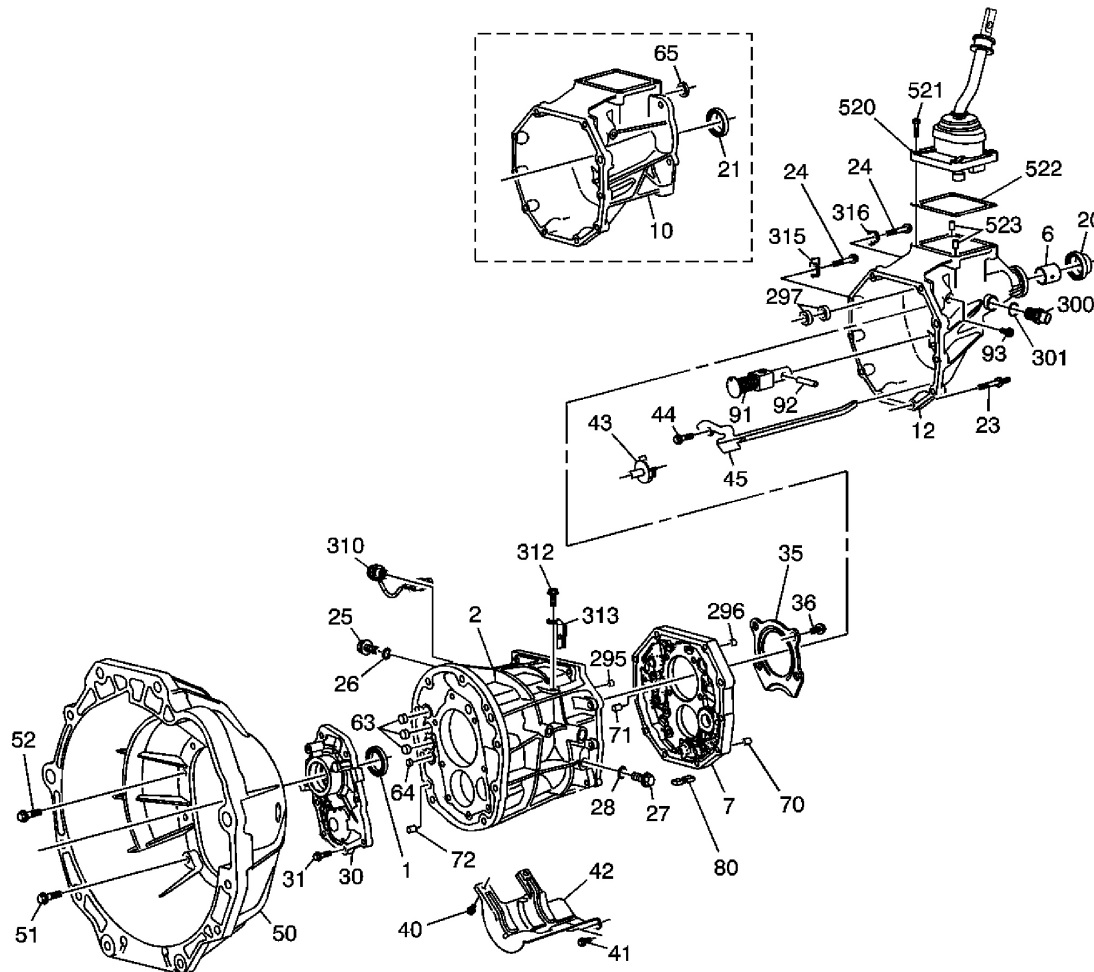

Fig. 4: Transmission Cases Disassembled View
 Courtesy of GENERAL MOTORS CORP.

Callouts For Fig. 4

Callout	Component Name
1	Input Shaft Seal
2	Transmission Front Case
6	Rear Bushing

2007 Hummer H3

2007 TRANSMISSION Manual Transmission - Aisin AR5 - H3

7	Transmission Intermediate Case
10	4WD Extension Housing
12	RWD Extension Housing
20	RWD Output Shaft Seal
21	4WD Output Shaft Seal
23	Extension Housing Stud
24	Extension Housing Bolt
24	Extension Housing Bolt
25	Oil Drain Plug
26	Oil Drain Plug Gasket
27	Oil Fill Plug
28	Oil Fill Plug Gasket
30	Front Bearing Retainer
31	Front Bearing Retainer Bolt
35	Rear Bearing Retainer
36	Rear Bearing Retainer Bolt
40	Oil Baffle Bolt to Shift Shaft
41	Oil Baffle Bolt to Intermediate Case
42	Oil Baffle
43	Oil Receiver
44	Oil Trough Bolt, RWD Only
45	Oil Trough, RWD Only
50	Clutch Housing
51	Clutch Housing Bolt
52	Clutch Housing Bolt with Sealer
63	Shift Shaft Bushing Large Plug
64	Shift Shaft Bushing Small Plug
65	Shift Rail Plug
70	Intermediate Case Rear Location Pin
71	Intermediate Case Front Location Pin
72	Case Location Pin
80	Chip Collector Magnet
91	Reverse Control Lever Restrictor
92	Reverse Control Lever Restrictor Pin
93	Reverse Control Lever Restrictor Pin Plug

2007 Hummer H3

2007 TRANSMISSION Manual Transmission - Aisin AR5 - H3

	Front Case Shift Shaft Bushing
296	Intermediate Case Shift Shaft Bushing
297	Extension Housing Shift Shaft Bushing
300	Vehicle Speed Sensor (VSS), RWD Only
301	VSS O-Ring Seal, RWD Only
310	Backup Lamp Switch
312	Bracket Bolt
313	Wiring Harness Bracket
315	Extension Lower Bracket
316	Extension Upper Bracket
520	Shift Control Lever Assembly
521	Control Lever Housing Bolt
522	Shift Control Housing Gasket
523	Shift Control Housing Location Pin

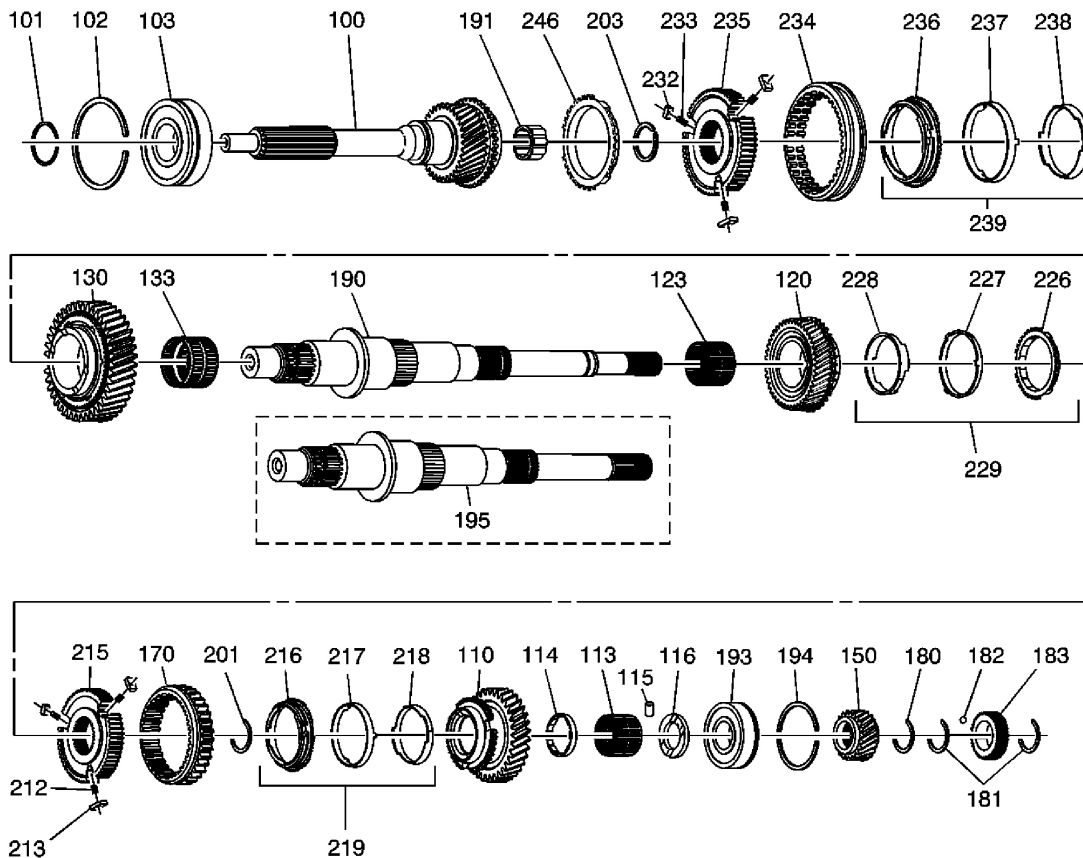

Fig. 5: Input Shaft and Output Shaft Components Disassembled View

2007 Hummer H3

2007 TRANSMISSION Manual Transmission - Aisin AR5 - H3

Courtesy of GENERAL MOTORS CORP.**Callouts For Fig. 5**

Callout	Component Name
100	Input Shaft
101	Input Shaft Bearing Retaining Ring
102	Input Shaft Bearing Outer Retaining Ring
103	Input Shaft Bearing
110	1st Gear
113	1st Gear Bearing
114	1st Gear Bearing Spacer
115	1st Gear Thrust Washer Lock Pin
116	1st Gear Thrust Washer
120	2nd Gear
123	2nd Gear Bearing
130	3rd Gear
133	3rd Gear Bearing
150	5th Gear
170	Reverse Gear
180	5th Gear Retaining Ring
181	Speed Sensor Reluctor Wheel Retaining Ring, RWD Only
182	Speed Sensor Reluctor Wheel Locating Ball, RWD Only
183	Speed Sensor Reluctor Wheel, RWD Only
190	RWD Output Shaft
191	Output Shaft Front Support Bearing
193	Output Shaft Rear Bearing
194	Output Shaft Rear Bearing Outer Retaining Ring
195	4WD Output Shaft
201	1st/2nd Gear Synchronizer Hub Retaining Ring
203	3rd/4th Gear Synchronizer Hub Retaining Ring
212	1st/2nd Gear Synchronizer Spring
213	1st/2nd Gear Synchronizer Insert
215	1st/2nd Gear Synchronizer Hub
216	1st Gear Outer Blocking Ring
217	1st Gear Internal Blocking Ring

2007 Hummer H3

2007 TRANSMISSION Manual Transmission - Aisin AR5 - H3

218	1st Gear Inner Blocking Ring
219	1st Gear Blocking Ring Assembly
226	2nd Gear Outer Blocking Ring
227	2nd Gear Internal Blocking Ring
228	2nd Gear Inner Blocking Ring
229	2nd Gear Blocking Ring Assembly
232	3rd/4th Gear Synchronizer Insert
233	3rd/4th Gear Synchronizer Spring
234	3rd/4th Gear Synchronizer Sleeve
235	3rd/4th Gear Synchronizer Hub
236	3rd Gear Outer Blocking Ring
237	3rd Gear Internal Blocking Ring
238	3rd Gear Inner Blocking Ring
239	3rd Gear Blocking Ring Assembly
246	4th Gear Blocking Ring

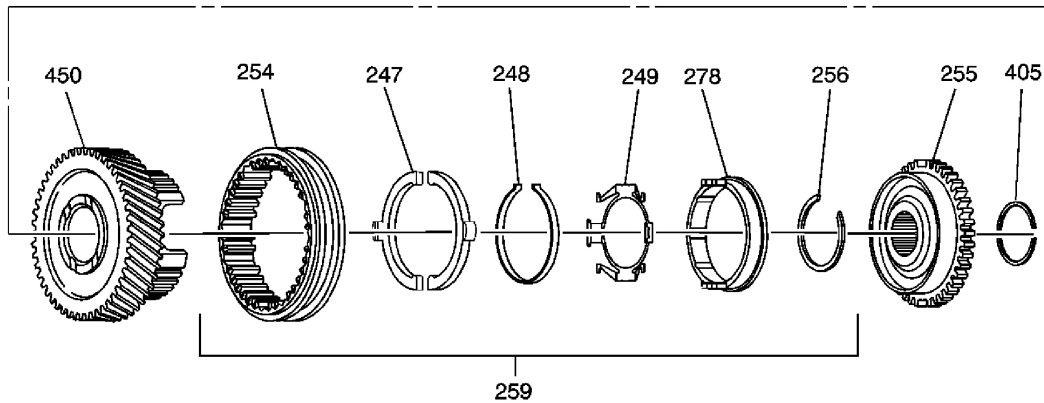
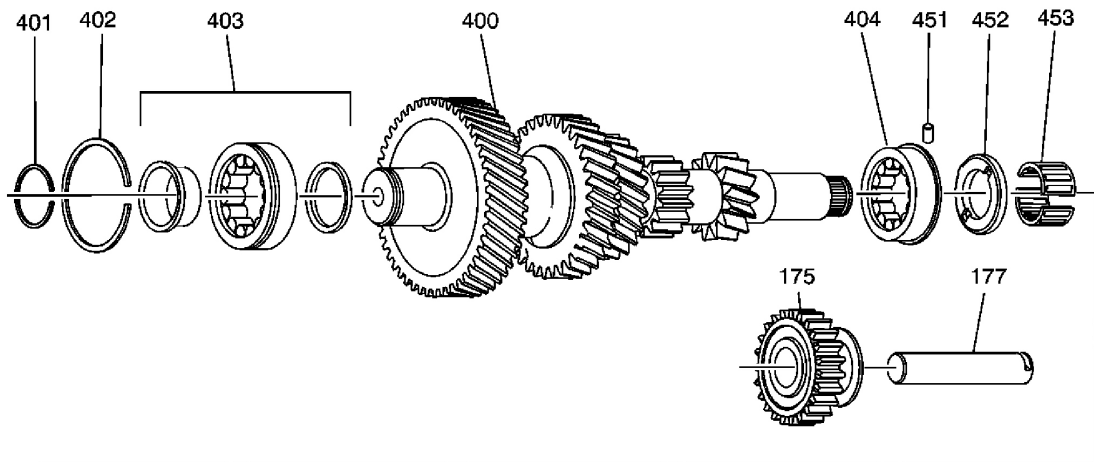

Fig. 6: Countershaft & Reverse Idler Shaft Components Disassembled View
Courtesy of GENERAL MOTORS CORP.

Callouts For Fig. 6

Callout	Component Name
175	Reverse Idler Gear
177	Reverse Idler Gear Shaft
247	5th Gear Synchronizer Insert
248	5th Gear Synchronizer Spring
249	5th Gear/Reverse Synchronizer Spring
254	5th/Reverse Synchronizer Sleeve
255	5th Synchronizer Gear
256	5th Gear/Reverse Synchronizer Spring Retainer Ring
259	5th/Reverse Gear Synchronizer Assembly
278	Reverse/5th Gear Synchronizer Ring
400	Countershaft
401	Countershaft Front Bearing Retaining Ring
402	Countershaft Front Bearing Outer Retaining Ring
403	Countershaft Front Bearing
404	Countershaft Rear Bearing
405	5th Synchronizer Gear Retaining Ring
450	5th Countershaft Gear
451	5th Countershaft Gear Thrust Washer Lock Pin
452	5th Countershaft Gear Thrust Washer
453	5th Countershaft Gear Bearing

2007 Hummer H3

2007 TRANSMISSION Manual Transmission - Aisin AR5 - H3

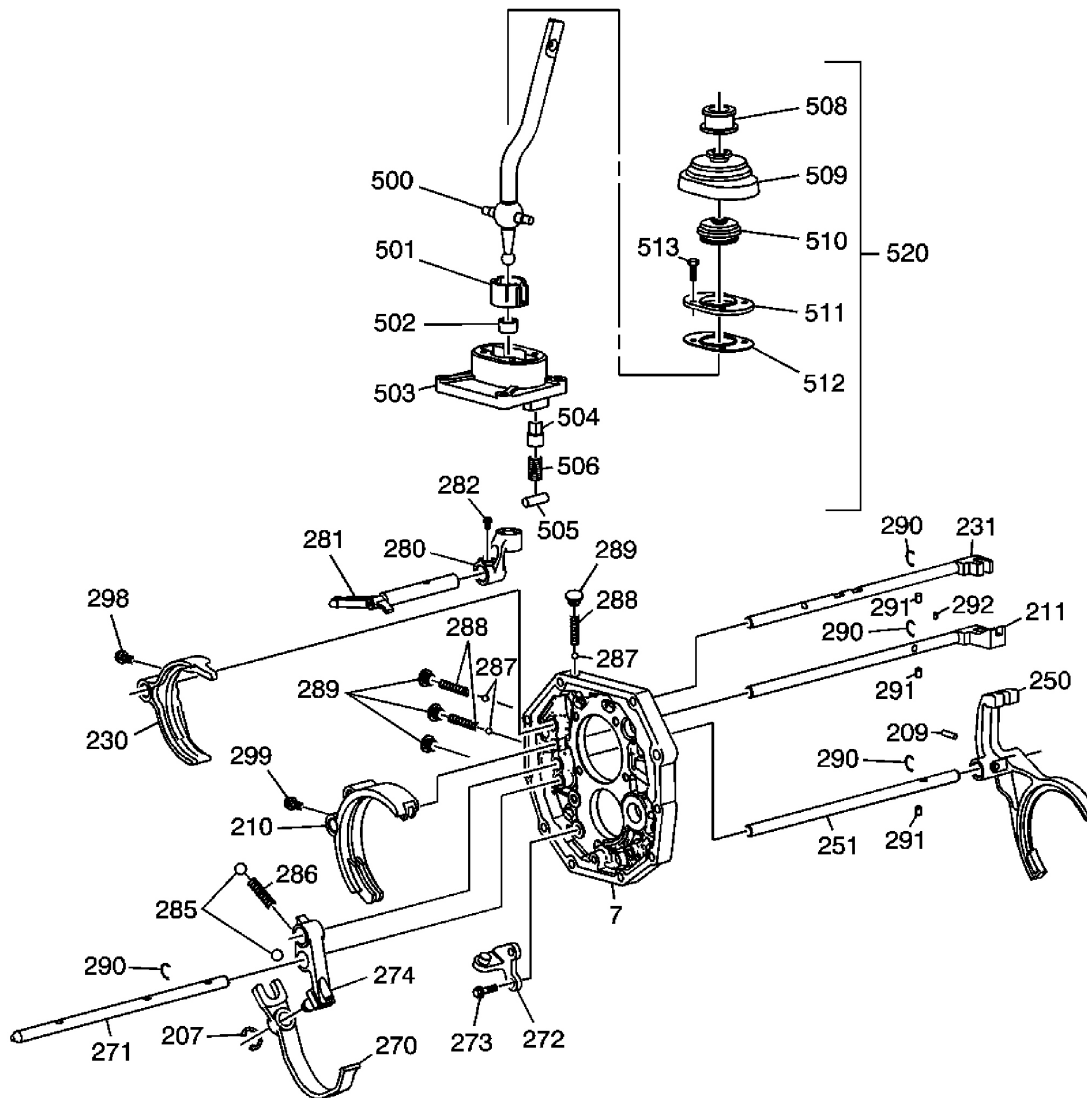

Fig. 7: Shift Control & Shift Components Disassembled View
 Courtesy of GENERAL MOTORS CORP.

Callouts For Fig. 7

Callout	Component Name
7	Transmission Intermediate Case
207	Reverse Shift Fork Retaining Ring
209	5th Shift Fork Pin
210	1st/2nd Shift Fork
211	1st/2nd Shift Shaft
230	3rd/4th Shift Fork

2007 Hummer H3

2007 TRANSMISSION Manual Transmission - Aisin AR5 - H3

231	3rd/4th Shift Shaft
250	5th Shift Fork
251	5th Shift Shaft
270	Reverse Shift Fork
271	Reverse Shift Shaft
272	Reverse Shift Fork Bracket
273	Reverse Shift Fork Bracket Bolt
274	Reverse Shift Lever
280	Shift Control Lever Socket
281	Shift Control Shaft
282	Shift Control Lever Socket Bolt
285	Reverse Shift Shaft Detent Ball
286	Reverse Shift Shaft Detent Spring
287	Shift Shaft Detent Ball
287	Shift Shaft Detent Ball
288	Shift Shaft Detent Spring
288	Shift Shaft Detent Spring
289	Shift Shaft Detent Plug
289	Shift Shaft Detent Plug
290	Shift Shaft Retaining Ring
290	Shift Shaft Retaining Ring
290	Shift Shaft Retaining Ring
290	Shift Shaft Retaining Ring
291	Shift Shaft Interlock Pin
291	Shift Shaft Interlock Pin
291	Shift Shaft Interlock Pin
292	1st/2nd Shift Shaft Interlock Pin
298	3rd/4th Shift Fork Bolt
299	1st/2nd Shift Fork Bolt
500	Shift Control Lever
501	Shift Control Lever Spring Seat
502	Shift Control Lever Shaft Bushing
503	Shift Control Housing
504	Shift Control Lever Plunger
505	Shift Lever Pin

2007 Hummer H3

2007 TRANSMISSION Manual Transmission - Aisin AR5 - H3

	Shift Control Lever Shaft Spring
508	Shift Control Lever Shaft Seal
509	Control Lever Boot
510	Shift Control Shaft Boot
511	Shift Control Lever Retainer
512	Control Lever Housing Gasket
513	Shift Control Lever Retainer Bolt
520	Shift Control Lever Assembly

DIAGNOSTIC INFORMATION AND PROCEDURES

DIAGNOSTIC CODE INDEX

DIAGNOSTIC CODE INDEX

DTC	Description
DTC P0502	Vehicle Speed Sensor (VSS) Circuit Low Voltage
DTC P0503	Vehicle Speed Sensor (VSS) Circuit Intermittent

DIAGNOSTIC STARTING POINT - MANUAL TRANSMISSION

Begin the system diagnosis with **Diagnostic System Check - Vehicle** . The Diagnostic System Check will provide the following information:

- The identification of the control module or modules which command the system.
- The ability of the control module or modules to communicate through the serial data circuit.
- The identification of any stored DTCs and the status of the codes.

Use the **Diagnostic System Check - Vehicle** in order to identify the correct procedure for diagnosing the system and where the procedure is located.

SCAN TOOL DATA LIST

Use the scan tool data values under the following conditions:

- The **Diagnostic System Check - Vehicle** is complete.
- The on-board diagnostics (OBDS) are functioning properly.
- No DTCs are present.

The values below represent a typical display recorded from a properly functioning system.

IMPORTANT: Do not use a scan tool that displays faulty data. Report the condition to the scan tool manufacturer. The use of a faulty scan tool can result in misdiagnosis and the unnecessary replacement of parts.

Only the parameters listed below are used in this manual for diagnosing. If a scan tool displays other parameters, the values are not recommended by General Motors for use in diagnosis.

Scan tool values below were recorded under the following conditions:

- Engine at idle
- Upper radiator hose hot
- Closed throttle
- Transmission in Neutral
- Closed Loop operation
- Accessories OFF
- Brake pedal not applied

Scan Tool Data List

Scan Tool Parameter	Data List*	Units Displayed	Typical Data Values
Vehicle Speed Sensor	ALL	km/h (mph)	0

*Data List Legend

- Engine Data (1)
- Air Data (2)
- CMP Data (3)
- Evap Data (4)
- Fuel Trim Data (5)
- HO2S Data (6)
- Ignition Data (7)
- Induction Data (8)
- Misfire Data (9)
- TAC Data (10)
- Cooling/HVAC Data (11)
- Cruise Control Data (12)

- Electrical/Theft Data (13)
- IPC Data (14)
- I/M Data (15)

SCAN TOOL DATA DEFINITIONS

The Transmission Scan Tool Data Definitions contain a brief description of manual transmission related parameters available on the scan tool. The list is in alphabetical order. A given parameter may appear in any one of the data lists. In some cases, the parameter may appear more than once or in more than one data list in order to group certain related parameters together.

Vehicle Speed Sensor

This parameter displays the speed at which the vehicle is traveling. The scan tool displays vehicle speed as kilometers per hour (km/h), miles per hour (mph). The vehicle speed is calculated based on the input signal from the vehicle speed sensor.

DIAGNOSTIC TROUBLE CODE (DTC) TYPE DEFINITIONS

DTCs are categorized into emissions and non-emissions related types. If a DTC is set, the malfunction indicator lamp (MIL) and failure data are utilized by the control module diagnostic executive according to the DTC type. Each DTC is set based upon the individual DTCs running and setting criteria. Read the Action Taken When the DTC Sets and Conditions for Clearing the MIL/DTC in the supporting text for taking appropriate action to each DTC.

Emissions Related DTCs

Type A

The following actions occur at the time of the first failure:

- The MIL is turned ON.
- A DTC is stored in memory.
- The Freeze Frame/Failure Records are stored.
- The Failure Records are updated after the first failure of each ignition cycle.

Some Type A DTCs will not perform the above actions when the DTC first detects a failure. Two consecutive failures are required. This allows systems, such as evaporative emission (EVAP), to accurately identify what failure exists before setting a DTC and requesting MIL illumination.

Type B

The following actions occur at one of the following times:

- First failure:
 - The MIL is not turned ON.
 - A DTC is stored in memory as a Failed Last Test.
 - The Failure Records are stored.
- Second consecutive drive cycle with a failure:
 - The MIL is turned ON.
 - A DTC is stored in memory as a history DTC.
 - The Freeze Frame data is stored.
 - The Failure Records are stored.
- Second non-consecutive drive cycle with a failure:
 - The MIL is not turned ON.
 - A DTC is stored in memory as a Failed Last Test.
 - The Failure Records are stored.

Non-Emissions Related DTCs

Type C

The following actions occur at the time of a failure:

- The MIL does not turn ON.
- A DTC is stored in memory as a history DTC.
- The Failure Records are stored.
- The Failure Records are updated after the first failure of each ignition cycle.
- Some Type C DTCs may also cause an auxiliary service lamp to be illuminated, and/or display a message to the vehicle operator.

Type X

Actions did not occur. These DTCs are coded into the control module software, but will not run for one of the following reasons:

- The associated hardware is not installed with the vehicle emission package.
- The diagnostic is not required for the vehicle emission package.

DIAGNOSTIC TROUBLE CODE (DTC) LIST/TYPE

Diagnostic Trouble Code (DTC) List/Type

Description	Federal and California Emissions	Unleaded Fuel Export
DTC P0502	B	B
DTC P0503	B	B

DTC P0502

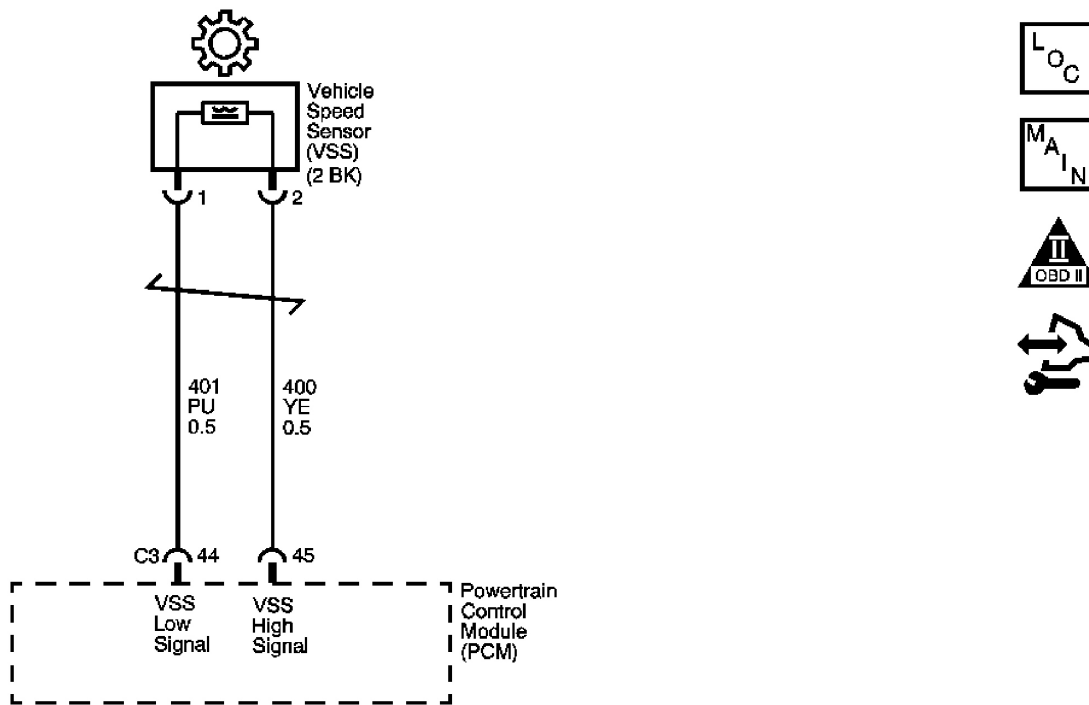

Fig. 8: Vehicle Speed Sensor (VSS) Circuit Schematic
 Courtesy of GENERAL MOTORS CORP.

Circuit Description

The vehicle speed sensor (VSS) assembly provides vehicle speed information to the powertrain control module (PCM). The VSS assembly is a permanent magnet generator. The VSS produces alternating current (AC) as the rotor teeth on the output shaft of the transmission, 2WD or transfer case, 4WD, pass through the magnetic field of the sensor. The frequency and amplitude of the AC waveform increase as vehicle speed increases.

If the PCM detects no vehicle speed for a specified length of time, while other sensors indicate that the vehicle is moving, DTC P0502 sets. DTC P0502 is a type B DTC.

DTC Descriptor

This diagnostic procedure supports the following DTC:

DTC P0502 Vehicle Speed Sensor (VSS) Circuit Low Voltage

Conditions for Running the DTC

- No VSS DTC P0503.
- No TP sensor DTCs P0120 or P0121.
- The TP sensor angle is 12 percent or more.
- The engine speed is 1,000-6,800 RPM for 8 seconds.
- The system voltage is 10-18 V.
- Engine torque is 40-300 N.m (30-221 lb ft).

Conditions for Setting the DTC

The transmission output speed is 100 RPM or less for 3 seconds.

Action Taken When the DTC Sets

- The PCM illuminates the malfunction indicator lamp (MIL) during the second consecutive trip in which the Conditions for Setting the DTC are met.
- The PCM disables Cruise Control.
- The PCM records the operating conditions when the Conditions for Setting the DTC are met. The PCM stores this information as Freeze Frame and Failure Records.
- The PCM stores DTC P0502 in PCM history during the second consecutive trip in which the Conditions for Setting the DTC are met.

Conditions for Clearing the MIL/DTC

- The PCM turns OFF the MIL during the third consecutive ignition cycles in which the diagnostic test runs and passes.
- A scan tool can clear the MIL/DTC.
- The PCM clears the DTC from PCM history if the vehicle completes 40 warm-up cycles without an emission-related diagnostic fault occurring.
- The PCM cancels the DTC default actions when the fault no longer exists and the DTC passes.

Diagnostic Aids

Ensure the VSS is correctly torqued to the transmission housing.

Test Description

The numbers below refer to the step numbers on the diagnostic table.

3: This step tests the ability of the VSS to produce an AC voltage. This step also verifies the integrity of the wiring to the PCM.

4: This step tests the VSS circuit for correct resistance.

DTC P0502

Step	Action	Value(s)	Yes	No
1	Did you perform the Diagnostic System Check - Vehicle?	-	Go to Step 2	Go to <u>Diagnostic System Check - Vehicle</u>
2	<ol style="list-style-type: none"> 1. Install a scan tool. 2. Turn ON the ignition, with the engine OFF. <p>IMPORTANT: Before clearing the DTC, use the scan tool in order to record the Freeze Frame and Failure Records. Using the Clear Info function erases the Freeze Frame and Failure Records from the PCM.</p> <ol style="list-style-type: none"> 3. Record the DTC Freeze Frame and Failure Records. 4. Clear the DTC. 5. Raise and support the drive wheels. 6. Start and idle the engine. 7. Engage the transmission in 2nd gear. 8. Select Vehicle Speed 	-	Go to <u>Testing</u> for	

2007 Hummer H3

2007 TRANSMISSION Manual Transmission - Aisin AR5 - H3

	Sensor on the scan tool. With the drive wheels rotating, does the VSS increase when the wheel speed increases?		<u>Intermittent Conditions and Poor Connections</u>	
				Go to Step 3
3	<ol style="list-style-type: none"> 1. Turn OFF the ignition. 2. Disconnect the PCM connector C3. 3. Using the J 35616 GM terminal test kit, connect the DMM between the VSS high signal circuit and the VSS low signal circuit at the PCM connector. 4. Select AC volts on the DMM. 5. Turn ON the ignition, with the engine OFF. 6. Rotate the right front drive wheel by hand. 7. Observe the DMM display. <p>Can a voltage greater than the specified value be obtained?</p>	0.5 V AC	Go to Step 14	
4	<ol style="list-style-type: none"> 1. Leave the DMM test leads connected. 2. Measure circuit resistance. <p>Is the circuit resistance within the specified range?</p>	1,300-3,160 ohms	Go to Step 8	Go to Step 5
5	Is the circuit resistance greater than the specified value?	3,160 ohms	Go to Step 11	Go to Step 6
6	<ol style="list-style-type: none"> 1. Leave the DMM test leads connected. 2. Disconnect the VSS connector at the transmission. 	1,300 ohms		

2007 Hummer H3

2007 TRANSMISSION Manual Transmission - Aisin AR5 - H3

	Is the circuit resistance less than the specified value?		Go to Step 7	Go to Step 13
7	Test the high signal circuit and the low signal circuit of the VSS for being shorted together. Refer to <u>Circuit Testing</u> and <u>Wiring Repairs</u> . Did you find and correct the condition?	-	Go to Step 15	-
8	Test the high signal circuit of the VSS for a short to ground. Refer to <u>Testing for Short to Ground</u> and <u>Wiring Repairs</u> . Did you find and correct the condition?	-	Go to Step 15	Go to Step 9
9	<ol style="list-style-type: none"> 1. Connect PCM connector C3. 2. Disconnect the VSS. 3. Select DC volts on the DMM. 4. Using the J 35616 , connect the DMM test leads to the VSS high signal circuit and the VSS low signal circuit of the VSS wiring harness connector. 5. Turn ON the ignition, with the engine OFF. Does the DMM display system voltage?	-	Go to Step 10	Go to Step 12
10	Test the high signal circuit of the VSS for a short to voltage. Refer to <u>Testing for a Short to Voltage</u> and <u>Wiring Repairs</u> . Did you find and correct the condition?	-	Go to Step 15	-

2007 Hummer H3

2007 TRANSMISSION Manual Transmission - Aisin AR5 - H3

11	<p>1. Test the high signal circuit of the VSS for an open.</p> <p>2. Test the low signal circuit of the VSS for an open.</p> <p>Refer to <u>Testing for Continuity</u> and <u>Wiring Repairs</u> .Did you find and correct a condition?</p>	-	Go to Step 15	Go to Step 13
12	<p>1. Remove the VSS. Refer to <u>Vehicle Speed Sensor Replacement</u>.</p> <p>2. Inspect the VSS and the transmission for the following conditions:</p> <ul style="list-style-type: none"> • Incorrect VSS • VSS damage • Excessive VSS to speed sensor rotor gap • Incorrect speed sensor rotor alignment • Speed sensor rotor damage <p>3. Repair any of the above conditions as necessary.</p> <p>Did you complete the repair?</p>	-	Go to Step 15	-
13	<p>Replace the VSS. Refer to <u>Vehicle Speed Sensor Replacement</u>.</p> <p>Did you complete the replacement?</p>	-	Go to Step 15	-
14	<p>Replace the PCM. Refer to <u>Control Module References</u> for replacement, setup and programming.</p> <p>Did you complete the replacement?</p>	-	Go to Step 15	-

15	<p>Perform the following procedure in order to verify the repair:</p> <ol style="list-style-type: none"> 1. Select DTC. 2. Select Clear Info. 3. Test drive the vehicle. 4. Select Specific DTC. 5. Enter DTC P0502. <p>Has the test run and passed?</p>	-	Go to Step 16	Go to Step 2
16	<p>With the scan tool, observe the stored information, capture info and DTC info.</p> <p>Does the scan tool display any DTCs that you have not diagnosed?</p>	-	Go to <u>Diagnostic Trouble Code (DTC) List - Vehicle</u>	System OK

DTC P0503

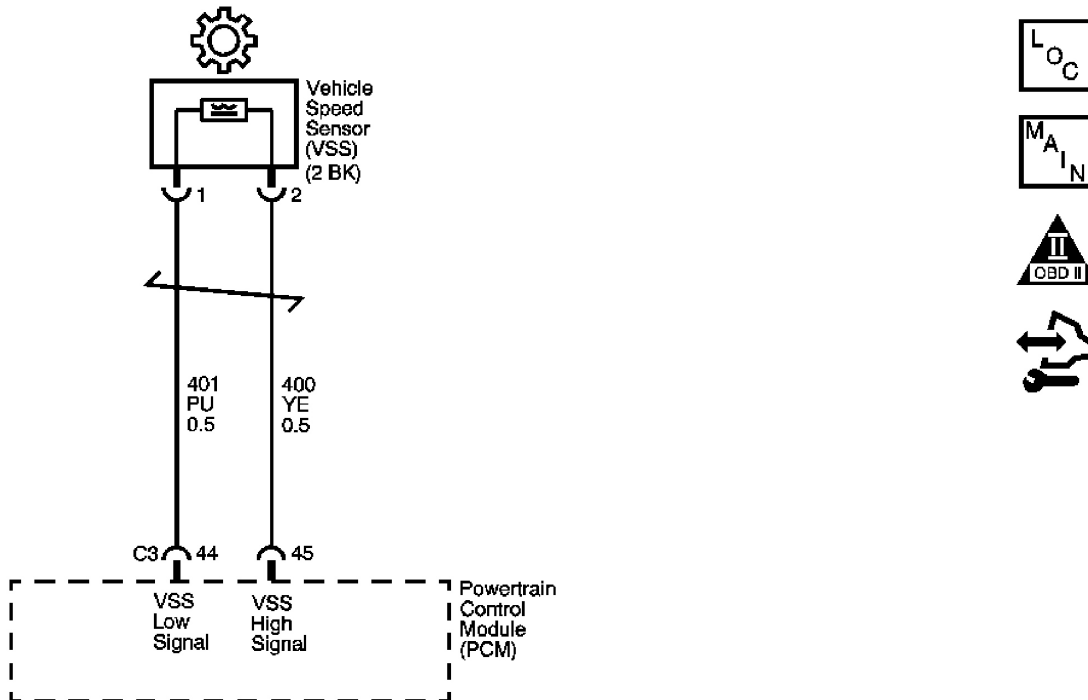

Fig. 9: Vehicle Speed Sensor (VSS) Circuit Schematic

Courtesy of GENERAL MOTORS CORP.

Circuit Description

The vehicle speed sensor (VSS) assembly provides vehicle speed information to the powertrain control module (PCM). The VSS assembly is a permanent magnet generator. The VSS produces alternating current (AC) as the rotor teeth on the output shaft of the transmission, 2WD or transfer case, 4WD, pass through the magnetic field of the sensor. The frequency and amplitude of the AC waveform increase as vehicle speed increases.

If the PCM detects no vehicle speed for a specified length of time, while other sensors indicate that the vehicle is moving, DTC P0503 sets. DTC P0503 is a type B DTC.

DTC Descriptor

This diagnostic procedure supports the following DTC:

DTC P0503 Vehicle Speed Sensor (VSS) Circuit Intermittent

Conditions for Running the DTC

- No VSS DTCs P0502.
- The engine speed is 450-6,800 RPM for 8 seconds.
- The system voltage is 10-18 V.
- The time since the last gear change is 6 seconds or more.
- The time since the last transfer case gear change is 3 seconds or more.
- The engine speed change is more than 500 RPM in 2 seconds.

Conditions for Setting the DTC

The transmission output speed must drop by 1,500 RPM in 0.5 seconds.

Action Taken When the DTC Sets

- The PCM illuminates the malfunction indicator lamp (MIL) during the second consecutive trip in which the Conditions for Setting the DTC are met.
- The PCM disables Cruise Control.
- The PCM records the operating conditions when the Conditions for Setting the DTC are met. The PCM stores this information as Freeze Frame and Failure Records.
- The PCM stores DTC P0503 in PCM history during the second consecutive trip in which the Conditions for Setting the DTC are met.

Conditions for Clearing the MIL/DTC

- The PCM turns OFF the MIL during the third consecutive ignition cycles in which the diagnostic test runs and passes.
- A scan tool can clear the MIL/DTC.
- The PCM clears the DTC from PCM history if the vehicle completes 40 warm-up cycles without an emission-related diagnostic fault occurring.
- The PCM cancels the DTC default actions when the fault no longer exists and the DTC passes.

Diagnostic Aids

Ensure the VSS is correctly torqued to the transmission housing.

Test Description

The numbers below refer to the step numbers on the diagnostic table.

3: This step tests the ability of the VSS to produce an AC voltage. This step also verifies the integrity of the wiring to the PCM.

4: This step tests the VSS circuit for correct resistance.

DTC P0503

Step	Action	Value(s)	Yes	No
1	Did you perform the Diagnostic System Check - Vehicle?	-	Go to Step 2	Go to <u>Diagnostic System Check - Vehicle</u>
	1. Install a scan tool. 2. Turn ON the ignition, with the engine OFF. IMPORTANT: Before clearing the DTC, use the scan tool in order to record the Freeze Frame and Failure Records. Using the Clear Info function erases the Freeze Frame and Failure Records from the PCM.			

2007 Hummer H3

2007 TRANSMISSION Manual Transmission - Aisin AR5 - H3

<p align="center">2</p>	<ol style="list-style-type: none"> 3. Record the DTC Freeze Frame and Failure Records. 4. Clear the DTC. 5. Raise and support the drive wheels. 6. Start and idle the engine. 7. Engage the transmission in 2nd gear. 8. Select Vehicle Speed Sensor on the scan tool. <p>With the drive wheels rotating, does the VSS increase when the wheel speed increases?</p>	<p align="center">-</p>	<p align="center">Go to <u>Testing for Intermittent Conditions and Poor Connections</u></p>	<p align="center">Go to Step 3</p>
<p align="center">3</p>	<ol style="list-style-type: none"> 1. Turn OFF the ignition. 2. Disconnect the PCM connector C3. 3. Using the J 35616 GM terminal test kit, connect the DMM between the VSS high signal circuit and the VSS low signal circuit at the PCM connector. 4. Select AC volts on the DMM. 5. Turn ON the ignition, with the engine OFF. 6. Rotate the right front drive wheel by hand. 7. Observe the DMM display. <p>Can a voltage greater than the specified value be obtained?</p>	<p align="center">0.5 V AC</p>	<p align="center">Go to Step 14</p>	<p align="center">Go to Step 4</p>
<p align="center">4</p>	<ol style="list-style-type: none"> 1. Leave the DMM test leads connected. 2. Measure circuit resistance. 	<p align="center">1,300-3,160</p>		

2007 Hummer H3

2007 TRANSMISSION Manual Transmission - Aisin AR5 - H3

	Is the circuit resistance within the specified range?	ohms	Go to Step 8	Go to Step 5
5	Is the circuit resistance greater than the specified value?	3,160 ohms	Go to Step 11	Go to Step 6
6	<ol style="list-style-type: none"> 1. Leave the DMM test leads connected. 2. Disconnect the VSS connector at the transmission. <p>Is the circuit resistance less than the specified value?</p>	1,300 ohms	Go to Step 7	Go to Step 13
7	<p>Test the high signal circuit and the low signal circuit of the VSS for being shorted together. Refer to <u>Circuit Testing</u> and <u>Wiring Repairs</u> .</p> <p>Did you find and correct the condition?</p>	-	Go to Step 15	-
8	<p>Test the high signal circuit of the VSS for a short to ground. Refer to <u>Testing for Short to Ground</u> and <u>Wiring Repairs</u> .</p> <p>Did you find and correct the condition?</p>	-	Go to Step 15	Go to Step 9
9	<ol style="list-style-type: none"> 1. Connect PCM connector C3. 2. Disconnect the VSS. 3. Select DC volts on the DMM. 4. Using the J 35616 , connect the DMM test leads to the VSS high signal circuit and the VSS low signal circuit of the VSS wiring harness connector. 5. Turn ON the ignition, with 	-		

2007 Hummer H3

2007 TRANSMISSION Manual Transmission - Aisin AR5 - H3

	the engine OFF. Does the DMM display system voltage?		Go to Step 10	Go to Step 12
10	Test the high signal circuit of the VSS for a short to voltage. Refer to <u>Testing for a Short to Voltage</u> and <u>Wiring Repairs</u> . Did you find and correct the condition?	-	Go to Step 15	-
11	1. Test the high signal circuit of the VSS for an open. 2. Test the low signal circuit of the VSS for an open. Refer to <u>Testing for Continuity</u> and <u>Wiring Repairs</u> .Did you find and correct a condition?	-	Go to Step 15	Go to Step 13
12	1. Remove the VSS. Refer to <u>Vehicle Speed Sensor Replacement</u> . 2. Inspect the VSS and the transmission for the following conditions: <ul style="list-style-type: none"> • Incorrect VSS • VSS damage • Excessive VSS to speed sensor rotor gap • Incorrect speed sensor rotor alignment • Speed sensor rotor damage 3. Repair any of the above conditions as necessary. Did you complete the repair?	-	Go to Step 15	-
	Replace the VSS. Refer to			

2007 Hummer H3

2007 TRANSMISSION Manual Transmission - Aisin AR5 - H3

13	<p><u>Vehicle Speed Sensor Replacement.</u> Did you complete the replacement?</p>	-	Go to Step 15	-
14	<p>Replace the PCM. Refer to <u>Control Module References</u> for replacement, setup and programming. Did you complete the replacement?</p>	-	Go to Step 15	-
15	<p>Perform the following procedure in order to verify the repair:</p> <ol style="list-style-type: none"> 1. Select DTC. 2. Select Clear Info. 3. Test drive the vehicle. 4. Select Specific DTC. 5. Enter DTC P0503. <p>Has the test run and passed?</p>	-	Go to Step 16	Go to Step 2
16	<p>With the scan tool, observe the stored information, capture info and DTC info. Does the scan tool display any DTCs that you have not diagnosed?</p>	-	Go to <u>Diagnostic Trouble Code (DTC) List - Vehicle</u>	System OK

SYMPTOMS - MANUAL TRANSMISSION

Strategy Based Diagnostics

Review the system operations in order to familiarize yourself with the system functions. Refer to **Transmission System Description and Operation.**

Visual/Physical Inspection

- Inspect the easily accessible or visible system components for obvious damage or conditions which could cause the symptom.

- Inspect the manual transmission for the correct fluid level.
- Inspect the manual transmission for fluid leaks.
- Inspect the manual transmission for broken or loose transmission mounts.

Intermittent

Test the vehicle under the same conditions that the customer reported in order to verify the system is operating properly.

Symptom List

Refer to a symptom diagnostic procedure from the following list in order to diagnose the symptom:

- **Transmission Shifts Hard**
- **Transmission Gear Clash When Shifting Gears**
- **Transmission Noisy**
- **Transmission Does Not Shift into One Gear**
- **Transmission Jumps Out of Gear**
- **Transmission Locked in One Gear**
- **Transmission Clunk on Acceleration or Deceleration**
- **Transmission Fluid Leak Diagnosis**

TRANSMISSION SHIFTS HARD

Diagnostic Aids

An intermittent hard shift may be caused by an intermittent clutch condition.

Test Description

The numbers below refer to the step numbers on the diagnostic table.

3: A static shift test is performed by shifting into all of the gear positions with the engine not operating. While performing the test, you should note how the shift lever movement is felt. Also, while shifting from one gear to another, feel for binding in the shift rails. You should be able to feel the detent plungers operating when coming out of a gear and going into a gear.

5: A dynamic shift test is performed by shifting into the gear positions with the engine

operating. Test for the correct mesh of the synchronizers and for the clutch releasing correctly. When shifting into and out of a gear, feel for the shift detent plungers and for the synchronizers sleeve for moving freely.

7: The transmission uses a special transmission fluid that allows proper synchronizer operation. The incorrect fluid may cause hard shifting by varnish build up or not enough lubrication for proper synchronizer operation.

Transmission Shifts Hard

Step	Action	Yes	No
<p>DEFINITION: The transmission does not shift smoothly or without difficulty, from one gear to the other.</p>			
1	<p>Did you review the Symptoms - Manual Transmission and perform the necessary inspections?</p>	Go to Step 2	Go to Symptoms - Manual Transmission
2	<p>Inspect the clutch system for proper operation. Refer to Clutch System Description and Operation . Did you find or repair the condition?</p>	Go to Step 11	Go to Step 3
3	<p>1. Perform a static shift test on the transmission. 2. Test for the following conditions:</p> <ul style="list-style-type: none"> • Blockage, preventing full shift lever movement • Excessive movement in the shift lever • Binding in the shift lever • Detent plungers or shift rails binding <p>Are you able to shift into all gears?</p>	Go to Step 5	Go to Step 4
4	<p>Remove the shift control housing and inspect for worn or faulty components. Refer to Control Lever and/or Boot Replacement. Did you find and repair the condition?</p>	Go to Step 11	Go to Step 5
	<p>1. Perform a dynamic shift test on the transmission.</p>		

2007 Hummer H3

2007 TRANSMISSION Manual Transmission - Aisin AR5 - H3

<p align="center">5</p>	<p>2. Test for the following conditions:</p> <ul style="list-style-type: none"> • Detent plungers or shift rails binding • Synchronizer sleeve binding • Gear clash into only one gear • Gear clash into all gears <p>Did the transmission shift hard into all gears?</p>	<p align="center">Go to Step 6</p>	<p align="center">Go to Step 10</p>
<p align="center">6</p>	<p>Inspect the transmission for the correct fluid level and type of transmission fluid. Refer to <u>Transmission Fluid Replacement</u>. Is the transmission fluid at the correct level and the proper fluid being used?</p>	<p align="center">Go to Step 8</p>	<p align="center">Go to Step 7</p>
<p align="center">7</p>	<p>Drain and fill the transmission with the correct type of fluid. Refer to <u>Transmission Fluid Replacement</u>. Did you find and repair the condition?</p>	<p align="center">Go to Step 11</p>	<p align="center">Go to Step 8</p>
<p align="center">8</p>	<p>1. Remove the transmission. Refer to <u>Transmission Replacement</u>.</p> <p>2. Inspect the clutch pressure plate and/or clutch driven plate.</p> <p>Is the clutch pressure plate and/or clutch driven plate worn or faulty?</p>	<p align="center">Go to Step 9</p>	<p align="center">Go to Step 10</p>
<p align="center">9</p>	<p>Replace the clutch assembly. Refer to <u>Clutch Assembly Replacement</u> . Did you find and repair the condition?</p>	<p align="center">Go to Step 11</p>	<p align="center">Go to Step 10</p>
	<p>1. Disassemble the transmission. Refer to <u>Transmission Disassemble</u>.</p> <p>2. Inspect the following components for being faulty, in the gear that is hard to shift or clashing:</p> <ul style="list-style-type: none"> • Excessive synchronizers blocking ring to gear clearance • Synchronizer hub external 		

2007 Hummer H3

2007 TRANSMISSION Manual Transmission - Aisin AR5 - H3

10	<p>splines worn or damaged</p> <ul style="list-style-type: none"> • Synchronizer sleeve spline edges worn or damaged • Excessive axial clearance in the speed gear from mainshaft, speed gear or thrust washer thrust surfaces worn or damaged • Mainshaft to speed gear bearing or journal worn • Shift rail and the internal shift control lever components for wear or damage • Shift fork worn or damaged <p>3. Replace worn or damaged components as necessary.</p>	Go to Step 10	Go to <u>Diagnostic Aids</u>
11	<p>Operate the system in order to verify the repair.</p> <p>Did you correct the condition?</p>	System OK	Go to Step 1

TRANSMISSION GEAR CLASH WHEN SHIFTING GEARS

Diagnostic Aids

Gear clash may be caused by shifting at too high of an engine RPM or by rushing the shift. If gear clash occurs in more than one gear, the clutch may not be releasing properly for proper synchronizer operation.

Test Description

The numbers below refer to the step numbers on the diagnostic table.

2: This step tests for the proper releasing of the clutch. If the clutch reserve is not proper, the mainshaft gears may still be turning, causing gear clash.

5: This step inspects for the proper transmission fluid. A special fluid is required for the correct lubrication of the synchronizers.

7: A static shift test is performed by shifting into all of the gear positions with the engine not operating. While performing the test, you should note how the shift lever movement is felt.

Also, while shifting from one gear to another, feel for binding in the shift rails. You should be able to feel the detent plungers operating when coming out of a gear and going into a gear. Excessive play in the gear shift lever may prevent the shift forks from fully engaging the synchronizer.

9: A dynamic shift test is performed by shifting into all of the gear positions with the engine operating. Test for the correct mesh of the synchronizers and for the clutch releasing correctly. Move the shift lever and feel for the synchronizer sleeve to just release from the gear, then let up on the clutch pedal. Depress the clutch pedal and move the shift lever to engage that gear again. If it shifts back into the gear without clashing, the clutch is releasing correctly and the synchronizer is working. If clashing occurs, test on another gear. If all gears clash, the clutch is not releasing correctly.

Transmission Gear Clash When Shifting Gears

Step	Action	Yes	No
DEFINITION: Noise from the transmission when shifting gears. A grinding or grating sound when the synchronizer sleeve is engaging with the selector teeth on the speed gear. A suspected internal transmission condition if the noise only occurs in one gear.			
1	Did you review the Symptoms - Manual Transmission and perform the necessary inspections?	Go to Step 2	Go to Symptoms - Manual Transmission
2	With the engine operating, does the transmission shift from neutral to any gear without the vehicle lurching or gear clashing?	Go to Step 5	Go to Step 3
3	Inspect for proper clutch operation. Refer to Clutch System Description and Operation . Does the clutch operate properly?	Go to Step 5	Go to Step 4
4	Repair the clutch system. Refer to Symptoms - Clutch . Did you find and repair the condition?	Go to Step 11	Go to Step 5
5	Inspect for the correct transmission fluid level and the proper fluid. Refer to Transmission Fluid Replacement . Is the transmission fluid level correct and at the proper level?	Go to Step 7	Go to Step 6
6	Fill the transmission fluid to the correct level or change the transmission fluid if it		

2007 Hummer H3

2007 TRANSMISSION Manual Transmission - Aisin AR5 - H3

	is not the correct type. Does the transmission still have gear clash?	Go to Step 7	Go to Step 11
7	<ol style="list-style-type: none"> 1. Perform a static shift test on the transmission. 2. Test for the following conditions: <ul style="list-style-type: none"> • Blockage, preventing full shift lever movement • Excessive movement in the shift lever • Binding in the shift lever • Detent plungers or shift rails binding <p>Did the transmission shift smoothly into the gear that is clashing?</p>	Go to Step 9	Go to Step 8
8	<p>Remove the shift control housing and inspect for damage or worn components. Refer to <u>Control Lever and/or Boot Replacement</u>.</p> <p>Did you find and repair the condition?</p>	Go to Step 11	Go to Step 9
9	<ol style="list-style-type: none"> 1. Perform a dynamic shift test on the transmission. 2. Test for the following conditions: <ul style="list-style-type: none"> • Detent plungers or shift rails binding • Synchronizer sleeve binding • Gear clashing in more than the suspected gear <p>Is the transmission hard to shift into all gears?</p>	Go to <u>Transmission Shifts Hard</u>	Go to Step 10
	<ol style="list-style-type: none"> 1. Disassemble the transmission. Refer to <u>Transmission Disassemble</u>. 2. Inspect the following transmission components for the gear that is clashing: 		

2007 Hummer H3

2007 TRANSMISSION Manual Transmission - Aisin AR5 - H3

10	<ul style="list-style-type: none"> • Excessive synchronizer blocking ring to gear clearance • Synchronizer sleeve to hub clearance excessive • Synchronizer sleeve spline edges worn or damaged • Excessive axial clearance in the speed gear from mainshaft and speed gear thrust surfaces worn or damaged • Mainshaft to speed gear bearing or journal worn • Shift fork worn or damaged • Internal shift control worn or damaged • Mainshaft bearing worn or damaged • Input gear bearing or pilot bearing worn • Countershaft bearings worn or damaged 		
	Did you find and repair the condition?	Go to Step 11	Go to <u>Diagnostic Aids</u>
11	Operate the system and verify the repair. Did you correct the condition?	System OK	Go to Step 1

TRANSMISSION NOISY

Test Description

The numbers below refer to the step numbers on the diagnostic table.

2: This step inspects for vibration causing a noise. If the vehicle is equipped with an aftermarket box or is carrying a certain load, the driveline axle may not be correct and could cause a vibration. The vibration maybe resonating into the transmission, causing a noise.

6: This step inspects for the correct transmission fluid level. If the transmission fluid level is excessively low, damage may have occurred to the transmission components.

8: This step inspects for the correct type of transmission fluid. The transmission uses a special fluid. If the incorrect fluid was used, there may have been an overheating condition. Overheating may cause damage to the transmission components.

10: This step inspects for noise coming into the driver compartment. Improper sealing of the shift tower may be allowing normal transmission noise to be heard by the driver.

16: This step tests to determine if clutch components are making the noise. Depress the clutch pedal slowly and listen for the change in noise. If the noise changes while pressing the pedal, the transmission component is faulty. If the noise does not change until the clutch is completely disengaged, it may be a faulty clutch component.

Transmission Noisy

Step	Action	Yes	No
DEFINITION: The transmission is making a noise. The different noises may be a whine or a growl caused by faulty bearings or gears. The noise may also be caused by a faulty component, causing a vibration noise or rattle.			
1	Did you review the Symptoms - Manual Transmission and perform the necessary inspections?	Go to Step 2	Go to Symptoms - Manual Transmission
2	Is the noise present at a certain road speed or with a certain load?	Go to Step 3	Go to Step 4
3	Inspect for the correct driveline angle. Refer to Driveline Working Angles Measurement . Did you find and repair the condition?	Go to Step 19	Go to Step 4
4	Is the noise present in all gears?	Go to Step 6	Go to Step 5
5	Is the noise present in just one gear?	Go to Step 18	Go to Step 6
6	Inspect the transmission fluid level. Is the fluid level correct?	Go to Step 8	Go to Step 7
7	Add transmission fluid. Refer to Transmission Fluid Replacement . Did you find and repair the condition?	Go to Step 19	Go to Step 8
8	Inspect the transmission for the correct fluid type. Refer to Lubrication Specifications . Is the transmission fluid the correct type?	Go to Step 10	Go to Step 9
9	Drain and fill the transmission with the correct type fluid. Refer to Transmission		

2007 Hummer H3

2007 TRANSMISSION Manual Transmission - Aisin AR5 - H3

	<u>Fluid Replacement.</u> Did you find and repair the condition?	Go to Step 19	Go to Step 10
10	Inspect the shift tower boot. Is the closeout boot loose or damaged?	Go to Step 11	Go to Step 12
11	Position and tighten the shift tower boot to specifications. Refer to <u>Control Lever and/or Boot Replacement.</u> Did you find and repair the condition?	Go to Step 19	Go to Step 12
12	Is the vehicle equipped with a transfer case?	Go to Step 13	Go to Step 14
13	Engage the transfer case in the different modes. Is the noise still present or the same?	Go to Step 14	Go to <u>Symptoms - Transfer Case</u>
14	<ol style="list-style-type: none"> 1. Inspect for engine to transmission alignment. 2. Inspect for loose transmission mounting bolts. Are there any loose transmission mounting bolts?	Go to Step 15	Go to Step 16
15	Replace and tighten the transmission mounting bolts. Refer to <u>Transmission Mount Replacement.</u> Is the noise still present?	Go to Step 16	Go to Step 19
16	With the engine operating, depress the clutch pedal. Is the noise still present?	Go to Step 17	Go to Step 18
17	<ol style="list-style-type: none"> 1. Remove the clutch. Refer to <u>Clutch Assembly Replacement .</u> 2. Inspect the following components for being the cause of the noise: <ul style="list-style-type: none"> • The release bearing • The pilot bearing • The pressure plate • The clutch disc • The engine crankshaft end play 		

2007 Hummer H3

2007 TRANSMISSION Manual Transmission - Aisin AR5 - H3

	Did you find and repair the condition?	Go to Step 19	Go to Step 18
18	1. Remove the transmission. Refer to <u>Transmission Replacement</u> . 2. Disassemble the transmission. Refer to <u>Transmission Disassemble</u> . Use the information in the Cleaning and Inspection section to determine if any of the transmission components are faulty.		-
	Did you find and repair the condition?	Go to Step 19	
19	Operate the system in order to verify the repair. Did you correct the condition?	System OK	Go to Step 1

TRANSMISSION DOES NOT SHIFT INTO ONE GEAR

Diagnostic Aids

If the transmission shifts into gear and then jumps out of gear, refer to **Transmission Jumps Out of Gear**. If the vehicle is equipped with a transfer case, during certain load conditions, the transfer case may fail. If it is an intermittent condition, other driveline components may be faulty.

Test Description

The numbers below refer to the step numbers on the diagnostic table.

2: This step is to confirm that the clutch is not slipping. During certain conditions, the clutch may slip and feel as though the transmission is not in gear.

3: A static shift test is performed by shifting into all gears with the engine not operating. While performing the test, you should note how the shift lever movement feels. Also, feel for the shift rails moving freely, the detent plungers operating when coming out of a gear and going in the next gear and the synchronizer sleeve movement.

5: A dynamic shift test is performed by shifting into all gears with the engine operating. Test for the correct mesh of the synchronizers sleeve and the speed gear selector teeth. Move the shift lever and feel for the synchronizer sleeve to just release from the gear, then let up on the clutch pedal. Depress the clutch pedal and move the shift lever to engage that gear again, to ensure full travel of the shift components.

Transmission Does Not Shift into One Gear

2007 Hummer H3

2007 TRANSMISSION Manual Transmission - Aisin AR5 - H3

Step	Action	Yes	No
DEFINITION: The shift lever will not move into a particular gear position or when it is in a gear position, power is not delivered through the transmission.			
1	Did you review the Symptoms - Manual Transmission and perform the necessary inspections?	Go to Step 2	Go to Symptoms - Manual Transmission
2	Inspect the clutch system for slipping. Refer to Clutch Slipping . Is the clutch operating properly?	Go to Step 2	Go to Clutch Assembly Replacement
3	1. Perform a static shift test on the transmission. 2. Test for the following conditions: <ul style="list-style-type: none"> • Blockage, preventing full shift lever movement • Excessive movement in the shift lever • Binding in the shift lever • Detent plungers or shift rails binding • Synchronizer sleeve moving on the hub and pressure pieces Were you able to shift into the gear position that has the concern?	Go to Step 5	Go to Step 4
4	Remove the shift control housing and inspect for worn or faulty components. Refer to Control Lever and/or Boot Replacement . Did you find and repair the condition?	Go to Step 8	Go to Step 5
5	1. Perform a dynamic shift test on the transmission. 2. Test for the following conditions: <ul style="list-style-type: none"> • Detent plungers or shift rails binding • Synchronizer sleeve binding • Synchronizer sleeve engaging 		

2007 Hummer H3

2007 TRANSMISSION Manual Transmission - Aisin AR5 - H3

	<p>on the speed gear selector teeth</p> <p>Were you able to shift into the gear position that has the concern?</p>	Go to Step 7	Go to Step 6
6	<ol style="list-style-type: none"> 1. Remove the transmission. Refer to <u>Transmission Replacement</u>. 2. Disassemble the transmission. Refer to <u>Transmission Disassemble</u>. 3. Inspect the following transmission internal components for wear or damage: <ul style="list-style-type: none"> • The shift forks • The internal shift control lever <p>Did you find and repair the condition?</p>	Go to Step 8	Go to Step 7
7	<ol style="list-style-type: none"> 1. Remove the transmission. Refer to <u>Transmission Replacement</u>. 2. Disassemble the transmission. Refer to <u>Transmission Disassemble</u>. 3. Inspect the following transmission internal components for wear or damage: <ul style="list-style-type: none"> • The synchronizer sleeve selector teeth • The speed gear selector teeth • The speed gear axial clearance for being excessive • The speed gear to mainshaft bearings and journals • The countershaft for being broken • The mainshaft for being broken • The countershaft gear for being stripped • The mainshaft gear for being stripped 		

2007 Hummer H3

2007 TRANSMISSION Manual Transmission - Aisin AR5 - H3

	Did you find and repair the condition?	Go to Step 8	Go to Diagnostic Aids
8	Operate the system in order to verify the repair. Did you correct the condition?	System OK	Go to Step 1

TRANSMISSION JUMPS OUT OF GEAR

Diagnostic Aids

If the transmission jumps out of gear during deceleration, inspect the components that may allow for the gears or shafts to tip. If the gears or shafts tip, the synchronizer sleeve can disengage from the selector teeth on the speed gear. If the transmission jumps out of gear during acceleration, inspect the components that may not allow full engagement of the synchronizer sleeve to the selector teeth on the speed gear. Insufficient engagement of the selector teeth under torque may cause the transmission to jump out of gear.

Test Description

The numbers below refer to the step numbers on the diagnostic table.

- 2:** A static shift test is performed by shifting into all gear positions with the engine not operating. While performing the test, slowly move the shift lever. Feel for proper movement of the shift lever and transmission internal shift components.
- 4:** A dynamic shift test is performed by shifting into all gear positions with the engine operating. Test for the correct mesh of the synchronizers sleeve and the speed gear selector teeth. Move the shift lever and feel for the synchronizer sleeve to release form the gear and then let up on the clutch pedal. Depress the clutch pedal and move the shift lever to engage the gear again, to ensure full travel of the shift components.
- 5:** This step inspects for worn or damaged transmission or engine mounts. Loose mounts may cause a shock on the transmission, allowing for gear disengagement.
- 6:** This step inspects for the misalignment of the clutch to transmission. Misalignment may put a bind on the input shaft, allowing for the input shaft or the mainshaft to tip.
- 8:** This step inspects the pilot bearing and the pilot bearing journal on the input shaft. A worn pilot bearing or input shaft may allow the input shaft to tip, causing gear disengagement.

Transmission Jumps Out of Gear

Step	Action	Yes	No

2007 Hummer H3

2007 TRANSMISSION Manual Transmission - Aisin AR5 - H3

DEFINITION: Gear disengagement occurs during acceleration or deceleration.

1	Did you review the Symptoms - Manual Transmission and perform the necessary inspections?	Go to Step 2	Go to Symptoms - Manual Transmission
2	<p>1. Perform a static shift test.</p> <p>2. Test for the following conditions:</p> <ul style="list-style-type: none"> • Blockage, preventing full shift lever movement • Excessive movement in the shift lever • Detent plungers engaging in the shift rails • Synchronizer pressure pieces on the synchronizer sleeves <p>Did the transmission shift completely into all gears?</p>	Go to Step 4	Go to Step 3
3	<p>Remove the shift control housing and inspect for worn or faulty components. Refer to <u>Control Lever and/or Boot Replacement</u>.</p> <p>Did you find and repair the condition?</p>	Go to Step 10	Go to Step 4
4	<p>1. Perform a dynamic shift test on the transmission.</p> <p>2. Test for the following:</p> <ul style="list-style-type: none"> • Synchronizer sleeve engagement to the speed gear selector teeth • Detent plungers engaging in the shift rails <p>Did the transmission shift completely into all gears?</p>	Go to Step 5	Go to Step 8
5	<p>Inspect the engine and/or transmission mounts. Refer to <u>Transmission Mount Replacement</u>.</p> <p>Did you find and repair the condition?</p>	Go to Step 10	Go to Step 6

2007 Hummer H3

2007 TRANSMISSION Manual Transmission - Aisin AR5 - H3

6	<p>Inspect the clutch housing for loose bolts or misalignment.</p> <p>Are there any loose bolts or misalignment?</p>	Go to Step 7	Go to Step 8
7	<ol style="list-style-type: none"> 1. Align the housing, if required. 2. Tighten any loose housing bolts. <p>Refer to <u>Transmission Replacement</u>.</p> <p>Did you find and repair the condition?</p>	Go to Step 10	Go to Step 8
8	<ol style="list-style-type: none"> 1. Remove the transmission. Refer to <u>Transmission Replacement</u>. 2. Remove the clutch assembly. Refer to <u>Clutch Assembly Replacement</u> . 3. Inspect the pilot bearing for being faulty. 4. Inspect the input shaft for excessive wear at the pilot bearing. <p>Did you find and repair the condition?</p>	Go to Step 10	Go to Step 9
9	<ol style="list-style-type: none"> 1. Disassemble the transmission. Refer to <u>Transmission Disassemble</u>. 2. Inspect the following components for wear or damage: <ul style="list-style-type: none"> • The shift rails • The detent plungers and springs • The shift forks • The synchronizer sleeve to shift fork clearance • The synchronizer sleeve and speed gear selector teeth • The mainshaft to input shaft bearing and journals • The speed gear bearings and journals • The speed gear axial clearance 		

2007 Hummer H3

2007 TRANSMISSION Manual Transmission - Aisin AR5 - H3

	<ul style="list-style-type: none"> • The mainshaft bearings • The countershaft bearings 		
	Did you find and repair the condition?	Go to Step 10	Go to <u>Diagnostic Aids</u>
10	Operate the system in order to verify the repair. Did you correct the condition?	System OK	Go to Step 1

TRANSMISSION LOCKED IN ONE GEAR

Test Description

The numbers below refer to the step numbers on the diagnostic table.

2: This step is to ensure the use of the proper transmission fluid. A special fluid is used to ensure proper synchronizer operation and for sufficient lubrication. Improper fluid may cause the synchronizers to stick or the transmission components to overheat.

4: A static shift test is performed by shifting into all gears with the engine not operating. By confirming that the transmission can be shifted into all positions, ensures that the shift lever is not excessively worn or damaged.

6: A dynamic shift test is performed by shifting into all of the gear positions with the engine operating. Test to ensure that the internal shift components are functioning properly.

Transmission Locked in One Gear

Step	Action	Yes	No
DEFINITION: The transmission cannot be shifted out of a gear or the vehicle will not move because the transmission is locked.			
1	Did you review the Symptoms - Manual Transmission and perform the necessary inspections?	Go to Step 2	Go to <u>Symptoms - Manual Transmission</u>
2	Inspect for the correct type of transmission fluid. Is the correct type transmission fluid being used?	Go to Step 4	Go to Step 3
3	Drain the transmission and fill with the correct type of fluid. Refer to <u>Transmission Fluid Replacement</u> . Did you find and repair the condition?	Go to Step 9	Go to Step 4

2007 Hummer H3

2007 TRANSMISSION Manual Transmission - Aisin AR5 - H3

4	<ol style="list-style-type: none"> 1. Perform a static shift test on the transmission. 2. Test for the shift lever moving to all positions. <p>Were you able to shift into all positions?</p>	Go to Step 6	Go to Step 5
5	<ol style="list-style-type: none"> 1. Remove the shift control housing. 2. Inspect for worn or faulty components. Refer to <u>Control Lever and/or Boot Replacement</u>. <p>Did you find and repair the conditions?</p>	Go to Step 9	Go to Step 6
6	<ol style="list-style-type: none"> 1. Perform a dynamic shift test on the transmission. 2. Test for being able to shift in and out of the gear with the concern. <p>Were you able to shift the transmission correctly?</p>	Go to Step 7	Go to Step 8
7	<ol style="list-style-type: none"> 1. Remove the transmission. Refer to <u>Transmission Replacement</u>. 2. Inspect the clutch system for the clutch not releasing properly. Refer to <u>Clutch System Description and Operation</u> . <p>Did you find and repair the condition?</p>	Go to Step 9	Go to Step 8
8	<ol style="list-style-type: none"> 1. Disassemble the transmission. Refer to <u>Transmission Disassemble</u>. 2. Inspect the following transmission internal components for wear or damage: <ul style="list-style-type: none"> • The shift rail • The internal shift control lever • The synchronizer components for being broken or faulty 		

2007 Hummer H3

2007 TRANSMISSION Manual Transmission - Aisin AR5 - H3

	<ul style="list-style-type: none"> The speed gears for being seized to the mainshaft or countershaft 		
	Did you find and repair the conditions?	Go to Step 9	Go to Diagnostic Aids
9	Operate the system in order to verify the repair. Did you correct the condition?	System OK	Go to Step 1

TRANSMISSION CLUNK ON ACCELERATION OR DECELERATION

Diagnostic Aids

All manual transmissions have gear play that might cause a clunk. If the transmission is suspected of causing the clunk, compare it with a similar vehicle. An internal clunk in the transmission is usually caused by wear between 2 components or from improper assembly, which would also cause other symptoms.

Test Description

The number below refers to the step number on the diagnostic table.

7: This step inspects for the transfer case causing the clunk. Shift the transfer case into another mode. If the transmission is causing the clunk, there will not be a change in the clunk.

Transmission Clunk on Acceleration or Deceleration

Step	Action	Yes	No
DEFINITION: A clunk is heard and/or felt on acceleration or deceleration.			
1	Did you review the Symptoms - Manual Transmission and perform the necessary inspections?	Go to Step 2	Go to Symptoms - Manual Transmission
2	Inspect the engine mounts for being loose or damaged. Refer to Engine Mount Inspection . Did you find and repair the condition?	Go to Step 10	Go to Step 3
3	Inspect the transmission mounts for being loose or damaged. Refer to Transmission Mount Replacement . Did you find and repair the condition?	Go to Step 10	Go to Step 4
	Inspect the transmission to engine fasteners		

2007 Hummer H3

2007 TRANSMISSION Manual Transmission - Aisin AR5 - H3

4	for being loose or missing. Refer to <u>Fastener Tightening Specifications.</u> Did you find and repair the condition?	Go to Step 10	Go to Step 5
5	Inspect the driveline for causing the clunk. Refer to <u>Diagnostic Starting Point - Propeller Shaft .</u> Did you find and repair the condition?	Go to Step 10	Go to Step 6
6	Is the vehicle equipped with a transfer case?	Go to Step 7	Go to Step 9
7	Shift the transfer case into 4HI. Is the clunk still present?	Go to Step 9	Go to Step 8
8	Inspect the transfer case for causing the clunk. Refer to <u>Symptoms - Transfer Case .</u> Did you find and repair the condition?	Go to Step 10	Go to Step 9
9	<ol style="list-style-type: none"> 1. Remove the transmission. Refer to <u>Transmission Replacement.</u> 2. Disassemble the transmission. Refer to <u>Transmission Disassemble.</u> 3. Inspect the following transmission components that could be causing the clunk: <ul style="list-style-type: none"> • Worn speed gear teeth • Worn countershaft gear teeth • Worn synchronizer sleeve to hub • Worn thrust washers and thrust surfaces on the speed gears or mainshaft Did you find and repair the condition?	Go to Step 10	Go to <u>Diagnostic Aids</u>
10	Operate the system in order to verify the repair. Did you correct the condition?	System OK	Go to Step 1

TRANSMISSION FLUID LEAK DIAGNOSIS

Diagnostic Aids

Using the incorrect type of transmission fluid may affect the sealing ability of the seals. Ensure the

use of the correct type of transmission fluid. The incorrect type of sealer may not be compatible with the transmission fluid or may not have the correct characteristics for sealing the affected components. Ensure the use of the correct type of sealers. Refer to **Sealers, Adhesives and Lubricants**.

Test Description

The numbers below refer to the step numbers on the diagnostic table.

3: Use an approved method to clean the transmission, to ensure the leak location is correctly identified. If using a powder method or dye method, ensure the products are compatible with the transmission fluid.

6: With the 4WD application, the sealing surface, for the transmission rear seal, is on the transfer case input shaft.

7: With the 4WD application, a weep hole is located at the transfer case to transmission flange. If fluid is leaking at the weep hole, verify if it is transmission fluid or transfer case fluid.

18: Two bolts, for the clutch housing, require the use of sealer.

Transmission Fluid Leak Diagnosis

Step	Action	Yes	No
DEFINITION: Visible sign of the transmission fluid leaking from the transmission.			
1	Did you review the Symptoms - Manual Transmission and perform the necessary inspections?	Go to Step 2	Go to <u>Symptoms - Manual Transmission</u>
2	<ol style="list-style-type: none"> Inspect for the transmission fluid level being higher than the recommended level. Refer to <u>Transmission Fluid Replacement</u>. Adjust the transmission level if incorrect. 		
	Was the transmission fluid level too high?	Go to Step 31	Go to Step 3
	Verify the location of the leak. <ol style="list-style-type: none"> Clean the transmission assembly. Operate the vehicle for 24 km (15 mi) or until normal operating 		

2007 Hummer H3

2007 TRANSMISSION Manual Transmission - Aisin AR5 - H3

<p align="center">3</p>	<p>temperatures are reached.</p> <p>3. Visually inspect or use the powder method or dye and black light method, to locate the leak.</p> <p>Is the leak occurring at the drain or fill plug?</p>	<p align="center">Go to Step 4</p>	<p align="center">Go to Step 5</p>
<p align="center">4</p>	<p>Replace the drain or fill plug gasket. Refer to <u>Transmission Fluid Replacement</u>. Did you find and repair the condition?</p>	<p align="center">Go to Step 31</p>	<p align="center">Go to <u>Diagnostic Aids</u></p>
<p align="center">5</p>	<p>Is the leak at the transmission output shaft seal?</p>	<p align="center">Go to Step 6</p>	<p align="center">Go to Step 7</p>
<p align="center">6</p>	<p>Remove the output shaft seal and inspect for the following conditions. Refer to <u>Transmission Housing Oil Seal Replacement - Rear</u>.</p> <ul style="list-style-type: none"> • Damaged or worn seal • Damaged seal bore • Improper installation • Cracks in the component • Propeller shaft yoke sealing surface is scratched, nicked, damaged or worn • If 4WD, transfer case input shaft seal surface damaged • Loose or worn bearing causing excessive seal wear <p>Did you find and repair the condition?</p>	<p align="center">Go to Step 31</p>	<p align="center">Go to <u>Diagnostic Aids</u></p>
<p align="center">7</p>	<p>If 4WD, is the leak at the transfer case to transmission weep hole?</p>	<p align="center">Go to Step 8</p>	<p align="center">Go to Step 9</p>
	<p>1. Remove the transfer case. Refer to <u>Transfer Case Assembly Replacement</u>.</p> <p>2. Inspect the shift shaft plug for</p>		

2007 Hummer H3

2007 TRANSMISSION Manual Transmission - Aisin AR5 - H3

8	<p>leaking.</p> <p>3. Replace the shift shaft plug if leaking. Refer to <u>Transmission Disassemble</u> and <u>Transmission Assemble</u>.</p> <p>Did you find and repair the condition?</p>	Go to Step 31	Go to Diagnostic Aids
9	Is the leak at the shift lever area?	Go to Step 10	Go to Step 11
10	<p>1. Inspect the shift control lever lower boot for damage.</p> <p>2. Inspect for loose shift control housing mounting bolts.</p> <p>3. Remove the shift control housing. Refer to <u>Control Lever and/or Boot Replacement</u>.</p> <p>4. Replace the shift control lever lower boot if damaged.</p> <p>5. Inspect the shift control lever sealing surfaces for scratched, nicked or damaged.</p> <p>Did you find and repair the condition?</p>	Go to Step 31	Go to <u>Diagnostic Aids</u>
11	Is the leak at the front of the transmission?	Go to Step 12	Go to Step 21
12	<p>1. Remove the transmission. Refer to <u>Transmission Replacement</u>.</p> <p>2. Remove the clutch actuator cylinder. Refer to <u>Clutch Actuator Cylinder Replacement</u>.</p> <p>Is the input shaft seal leaking?</p>	Go to Step 13	Go to Step 14
	<p>1. Inspect for the following conditions if the input shaft seal is leaking:</p> <ul style="list-style-type: none"> • Damaged or worn seal • Damaged seal bore • Improper installation • Cracks in the component • Input shaft sealing surface is 		

2007 Hummer H3

2007 TRANSMISSION Manual Transmission - Aisin AR5 - H3

13	<p>scratched, nicked, damaged or worn</p> <ul style="list-style-type: none"> • Loose or worn bearing causing excessive seal wear <p>2. Replace the input shaft seal if leaking. Refer to <u>Transmission Input Shaft Seal Replacement</u>.</p>	Go to Step 31	Go to Step 14
	Did you find and repair the condition?		
14	<p>Inspect the shift rail plug for leaking. Is the transmission leaking at the shift rail plug?</p>	Go to Step 15	Go to Step 16
15	<p>Replace the shift rail plug. Refer to <u>Transmission Disassemble</u> and <u>Transmission Assemble</u>.</p> <p>Did you find and repair the condition?</p>	Go to Step 31	Go to Step 1
16	<p>Inspect for leaking at the front retainer bolts. Is the transmission leaking at the front retainer bolts?</p>	Go to Step 17	Go to Step 18
17	<p>Remove the leaking front retainer bolts and install with the proper sealer. Refer to <u>Transmission Disassemble</u> and <u>Transmission Assemble</u>.</p> <p>Did you find and repair the condition?</p>	Go to Step 31	Go to Step 1
18	<p>Inspect for leaking at the clutch housing bolts. Is the transmission leaking at the clutch housing bolts?</p>	Go to Step 19	Go to Step 20
19	<p>Remove the leaking clutch housing bolts and install with the proper sealer. Refer to <u>Transmission Disassemble</u> and <u>Transmission Assemble</u>.</p> <p>Did you find and repair the condition?</p>	Go to Step 31	Go to Step 20
20	<ol style="list-style-type: none"> 1. Inspect the case for cracks or porosity. 2. Replace the transmission front case half if it is faulty. Refer to 		

2007 Hummer H3

2007 TRANSMISSION Manual Transmission - Aisin AR5 - H3

<u>Transmission Disassemble.</u>			Go to <u>Diagnostic Aids</u>
	Did you find and repair the condition?	Go to Step 31	
21	Is the leak at the vehicle speed sensor (VSS)?	Go to Step 22	Go to Step 23
22	<ol style="list-style-type: none"> 1. Remove the VSS. Refer to <u>Vehicle Speed Sensor Replacement.</u> 2. Inspect for the following conditions: <ul style="list-style-type: none"> • Cut or damaged O-ring seal • VSS over tightened causing deformation in the VSS • VSS bore scratched or damaged 		
	Did you find and repair the condition?	Go to Step 31	Go to Step 1
23	Is the leak at the backup lamp switch?	Go to Step 24	Go to Step 25
24	<ol style="list-style-type: none"> 1. Remove the backup lamp switch. Refer to <u>Backup Lamp Switch Replacement.</u> 2. Inspect for the following conditions: <ul style="list-style-type: none"> • Cross threaded or damaged threads • Insufficient sealant • Leaking switch • Improper installation 		
	Did you find and repair the condition?	Go to Step 31	Go to Step 1
25	Is the leak at the shift shaft detent plugs?	Go to Step 26	Go to Step 27
26	<ol style="list-style-type: none"> 1. Remove the shift shaft detent plugs. Refer to <u>Transmission Disassemble</u> and <u>Transmission Assemble.</u> 2. Inspect for the following conditions: <ul style="list-style-type: none"> • Cross threaded or damaged threads • Insufficient sealant • Cracked case 		

2007 Hummer H3

2007 TRANSMISSION Manual Transmission - Aisin AR5 - H3

	<ul style="list-style-type: none"> • Improper installation 		
	Did you find and repair the condition?	Go to Step 31	Go to Step 1
27	Is the leak at the sealing flanges of the transmission cases?	Go to Step 28	Go to Step 29
28	<ol style="list-style-type: none"> 1. Remove the transmission. Refer to <u>Transmission Replacement</u>. 2. Disassemble the transmission. Refer to <u>Transmission Disassemble</u>. 3. Inspect the sealing surfaces. Refer to <u>Transmission Case Cleaning and Inspection</u>. 		
	Did you find and repair the condition?	Go to Step 31	Go to Step 29
29	Is the leak coming from a crack or porosity in the transmission case?	Go to Step 30	Go to <u>Diagnostic Aids</u>
30	<ol style="list-style-type: none"> 1. Remove the transmission. Refer to <u>Transmission Replacement</u>. 2. Disassemble the transmission. Refer to <u>Transmission Disassemble</u>. 3. Replace the faulty case. Refer to <u>Transmission Extension Assemble</u> or <u>Transmission Case Assemble</u> or <u>Transmission Assemble</u>. 		
	Did you find and repair the condition?	Go to Step 31	Go to <u>Diagnostic Aids</u>
31	Operate the system in order to verify the repair. Did you correct the condition?	System OK	Go to Step 1

REPAIR INSTRUCTIONS - ON VEHICLE

TRANSMISSION FLUID REPLACEMENT

Draining Procedure

1. Raise and support the vehicle. Refer to **Lifting and Jacking the Vehicle** .

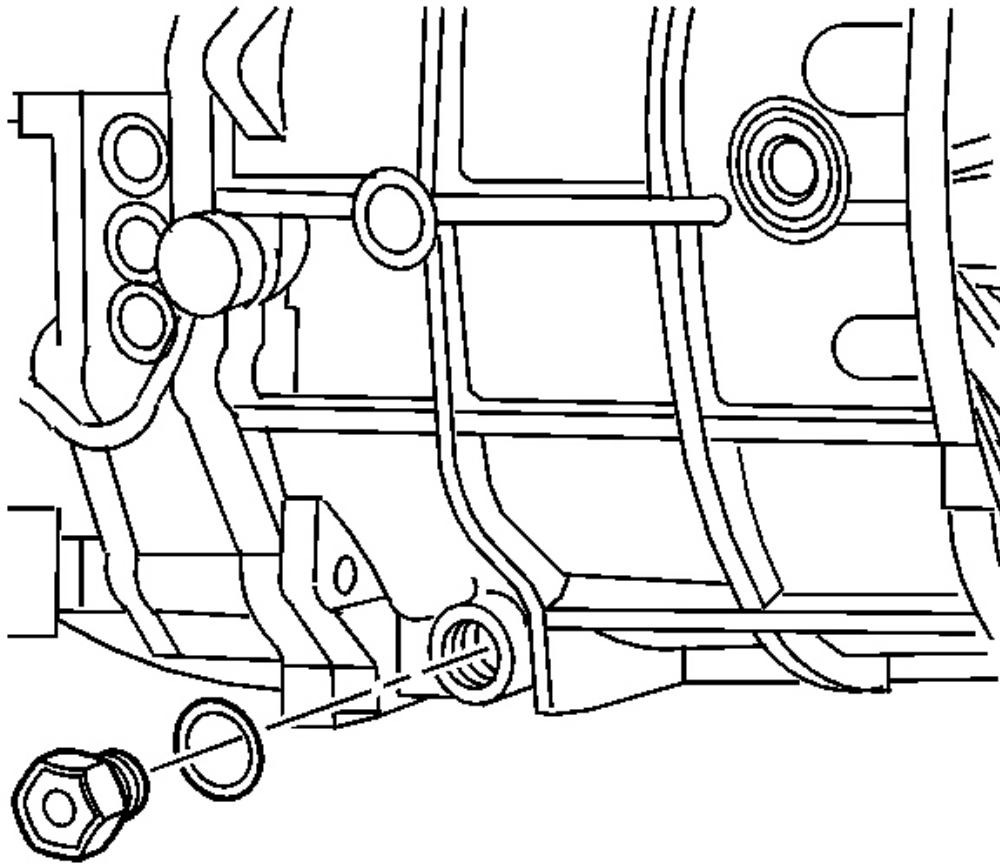

Fig. 10: View Of Drain Plug
Courtesy of GENERAL MOTORS CORP.

2. Clean away all dirt and debris from the transmission fluid drain plug area.
3. Position an appropriate container under the transmission.
4. Remove the transmission fluid drain plug and washer.

Discard the washer.

Allow the transmission fluid to drain into the container.

NOTE: Refer to **Component Fastener Tightening Notice** .

5. Install the transmission fluid drain plug and NEW washer.

Tighten: Tighten the drain plug to 37 N.m (27 lb ft).

6. Remove the container used to catch the used transmission fluid from under the vehicle.

Filling Procedure

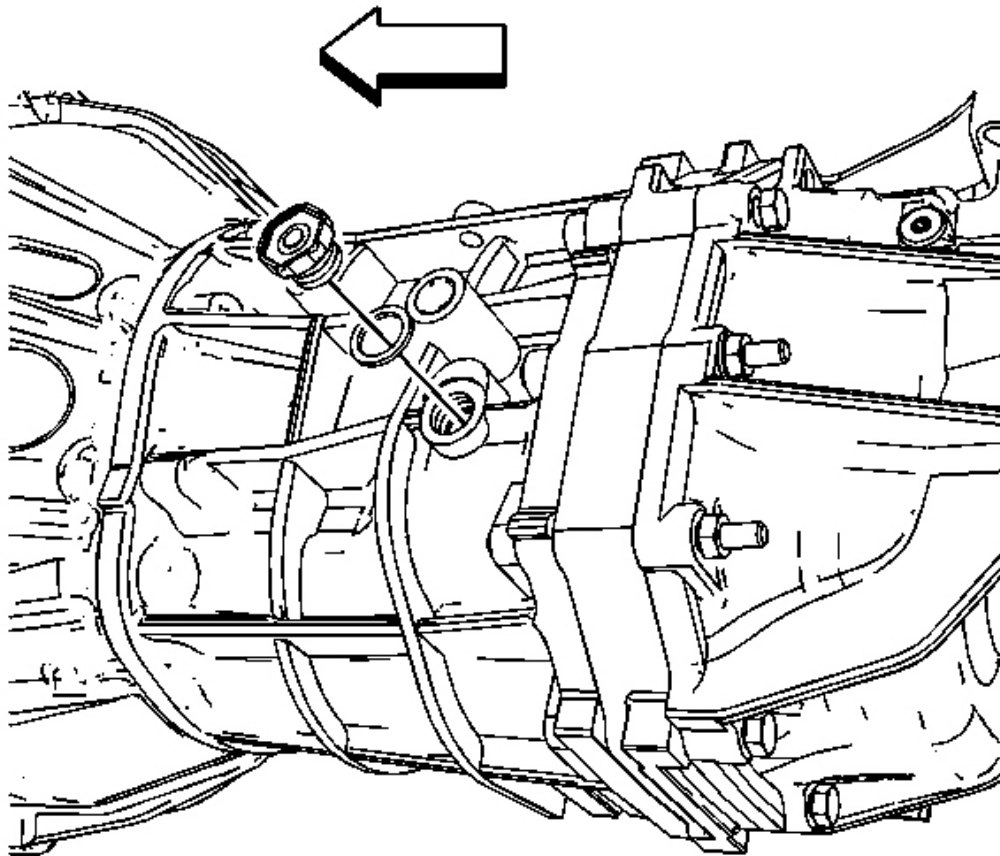

Fig. 11: View Of Transmission Fluid Fill Plug & Washer
Courtesy of GENERAL MOTORS CORP.

1. Clean away all dirt and debris from the transmission fluid fill plug area.
2. Remove the transmission fluid fill plug and washer.

Discard the washer.

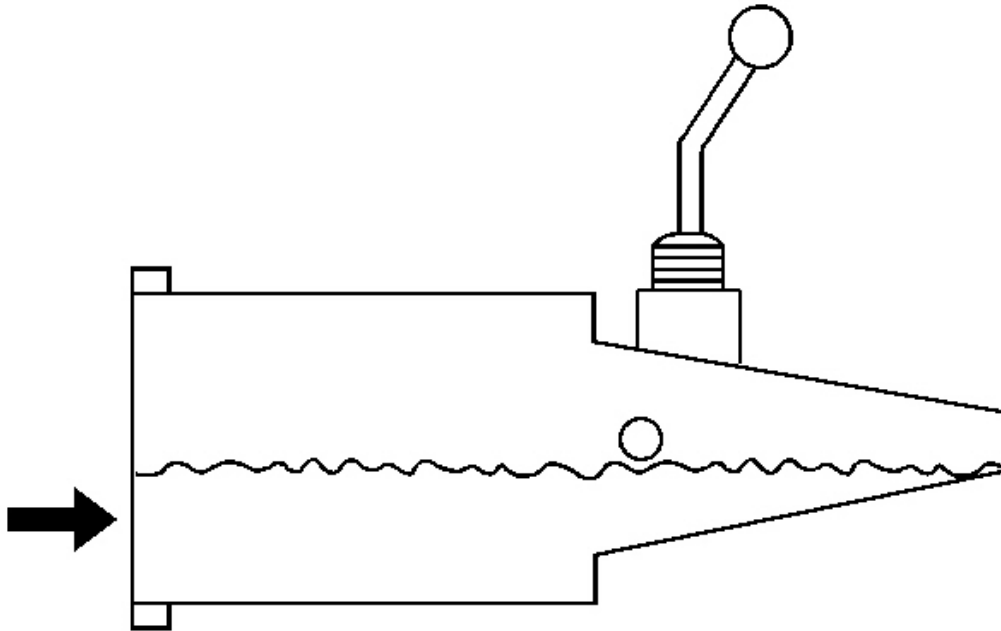

Fig. 12: Identifying Transmission Fluid Level
Courtesy of GENERAL MOTORS CORP.

3. Fill the transmission to just below the bottom of the fill plug hole with the recommended fluid. Refer to **Lubrication Specifications**.
4. Install the transmission fluid fill plug and NEW washer.

Tighten: Tighten the fill plug to 37 N.m (27 lb ft).

5. Lower the vehicle.

CONTROL LEVER AND/OR BOOT REPLACEMENT

Removal Procedure

1. Remove the shift lever assembly. Refer to **Shift Lever Assembly Replacement**.

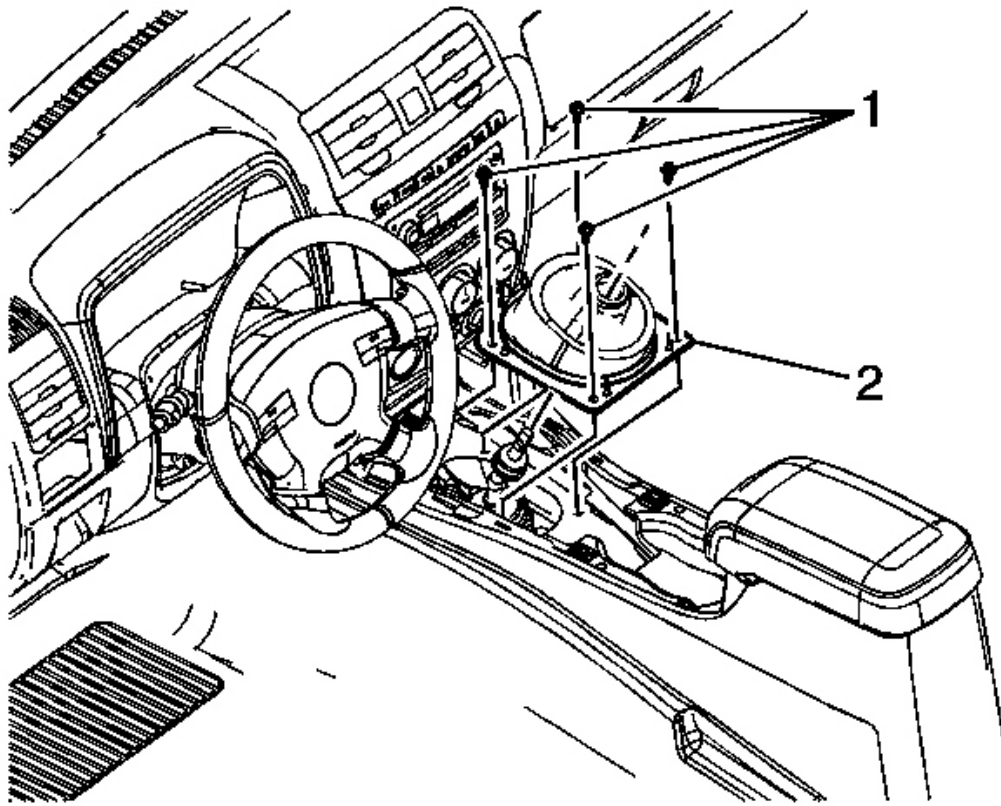

Fig. 13: Control Lever Boot Removal/Installation
Courtesy of GENERAL MOTORS CORP.

2. Remove the control lever boot screws (1).
3. Tilt and remove the control lever boot (2) from the control lever.
4. Shift the transmission into NEUTRAL.

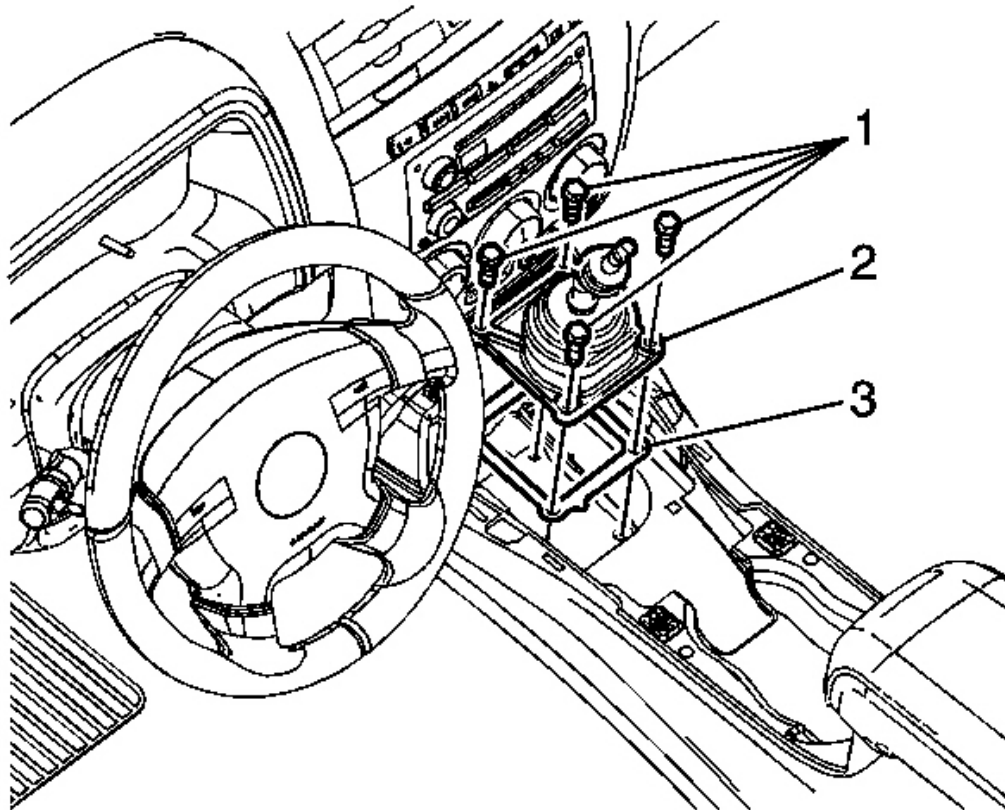

Fig. 14: Control Lever Housing Assembly Removal/Installation
Courtesy of GENERAL MOTORS CORP.

5. Remove the control lever housing assembly bolts (1).
6. Remove the control lever housing assembly (2) and gasket (3).
7. Mask off the control lever housing opening, in order to prevent foreign objects from entering the transmission.
8. Disassemble the control lever housing if necessary. Refer to **Shift Control Housing Disassemble**.

Installation Procedure

1. Assemble the control lever housing if previously disassembled. Refer to **Shift Control Housing Assemble**.

2. Remove the masking from the control lever opening and ensure the sealing surface is clean and dry.

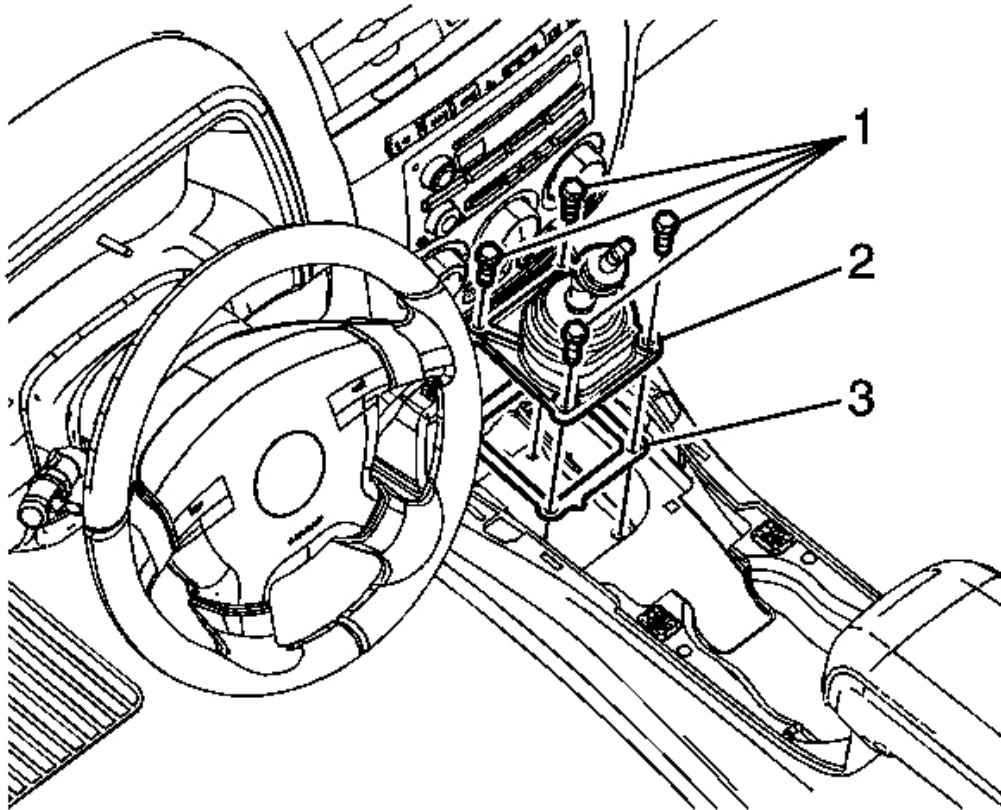

Fig. 15: Control Lever Housing Assembly Removal/Installation
Courtesy of GENERAL MOTORS CORP.

3. Place the control lever gasket (3) on to the transmission.
4. Position the control lever housing assembly (2) to the control lever assembly opening, aligning the bushing with the internal shift control lever.

NOTE: Refer to **Fastener Notice** .

5. Install the control lever housing assembly bolts (1).

Tighten: Tighten the bolts to 20 N.m (15 lb ft).

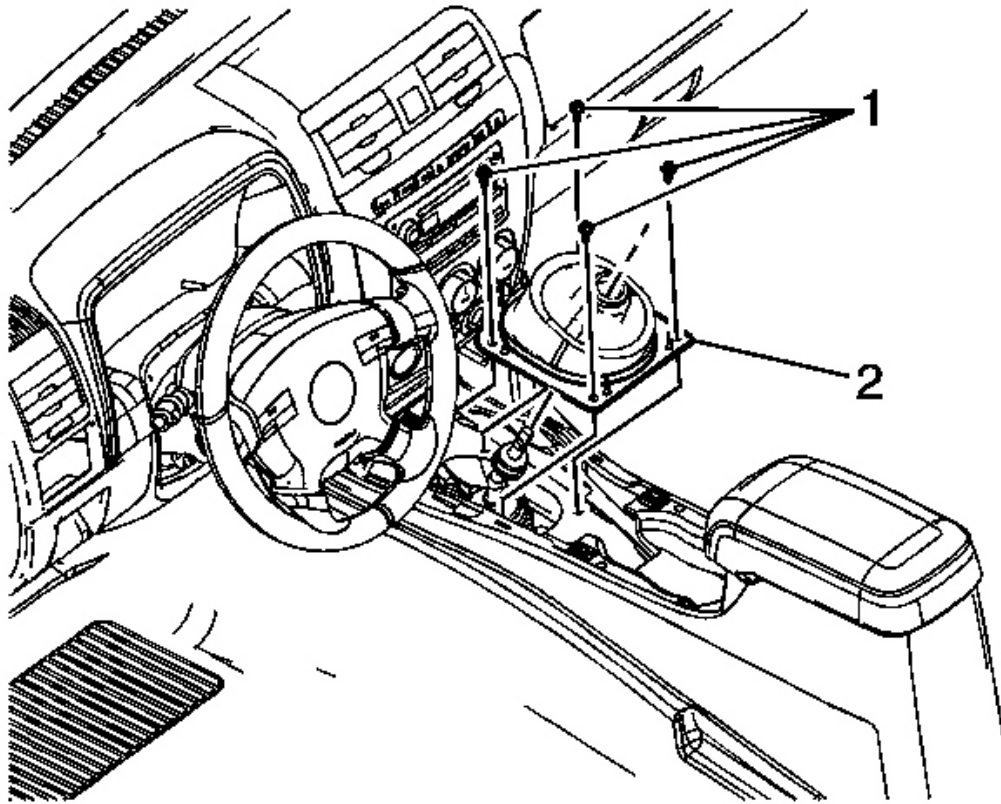

Fig. 16: Control Lever Boot Removal/Installation
Courtesy of GENERAL MOTORS CORP.

6. Slide the boot (2) into position over the control lever.

IMPORTANT: Ensure the carpet is not between the boot and the floor panel.

7. Tilt the boot (2) in order to seat to the floor.
8. Install the control lever boot screws (1).

Tighten: Tighten the screws to 2.5 N.m (22 lb in).

9. Install the shift lever assembly. Refer to **Shift Lever Assembly Replacement**.

SHIFT LEVER ASSEMBLY REPLACEMENT

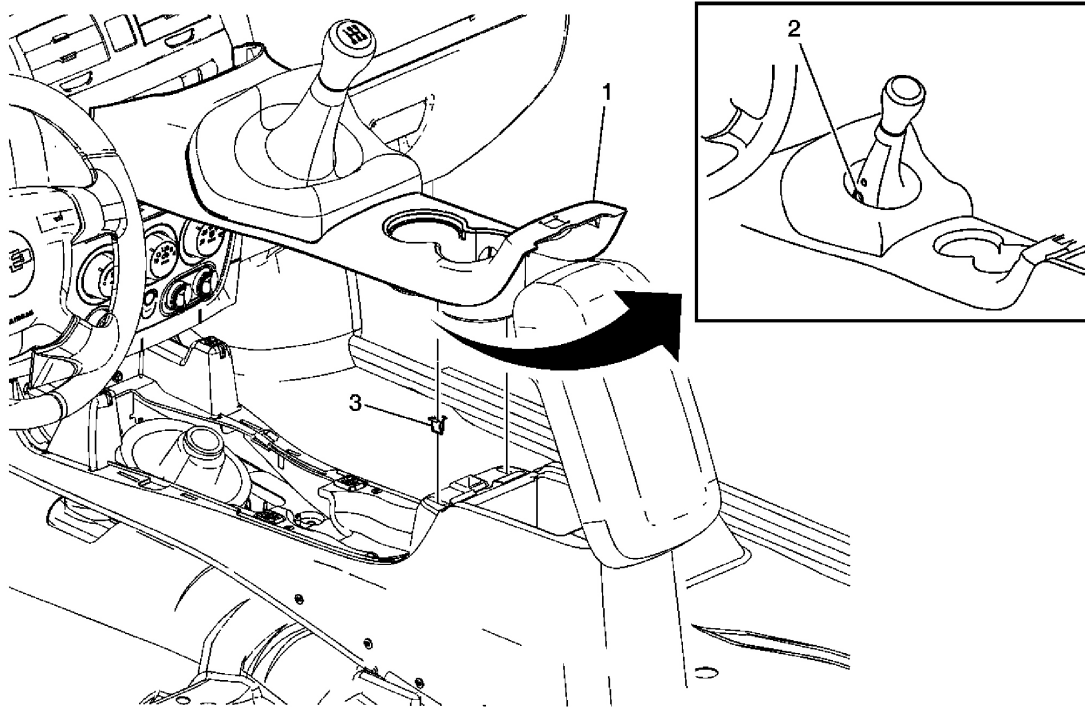

Fig. 17: Shift Lever Assembly Replacement
 Courtesy of GENERAL MOTORS CORP.

Shift Lever Assembly Replacement

Callout	Component Name
Fastener Tightening Specifications: Refer to <u>Fastener Tightening Specifications</u> .	
1	Plate, Console Upper Trim NOTE: Do NOT pull or pry on the shift boot. This action may damage the shift boot retainers. Tip: Shifter bezel and console upper trim plate must be removed as one assembly. For removal of the bezel from the trim plate, refer to <u>Console Shift Lever Bezel Replacement (Automatic Transmission)</u> or <u>Console Shift Lever Bezel Replacement (Manual Transmission)</u> .

2007 Hummer H3

2007 TRANSMISSION Manual Transmission - Aisin AR5 - H3

2	<p>Screw, Manual Shift Handle</p> <p>Tip:</p> <ol style="list-style-type: none">1. Lift the console upper trim plate enough to access the shift handle retaining screw.2. Apply threadlock GM P/N 1234593 (Canadian P/N 10953488) to the shift lever set screw threads before reinstalling. <p>Tighten: 25 N.m 18 lb ft)</p>
3	Retainer, Trim Clip (Qty 6)

VEHICLE SPEED SENSOR REPLACEMENT

Removal Procedure

1. Raise and support the vehicle. Refer to Lifting and Jacking the Vehicle .

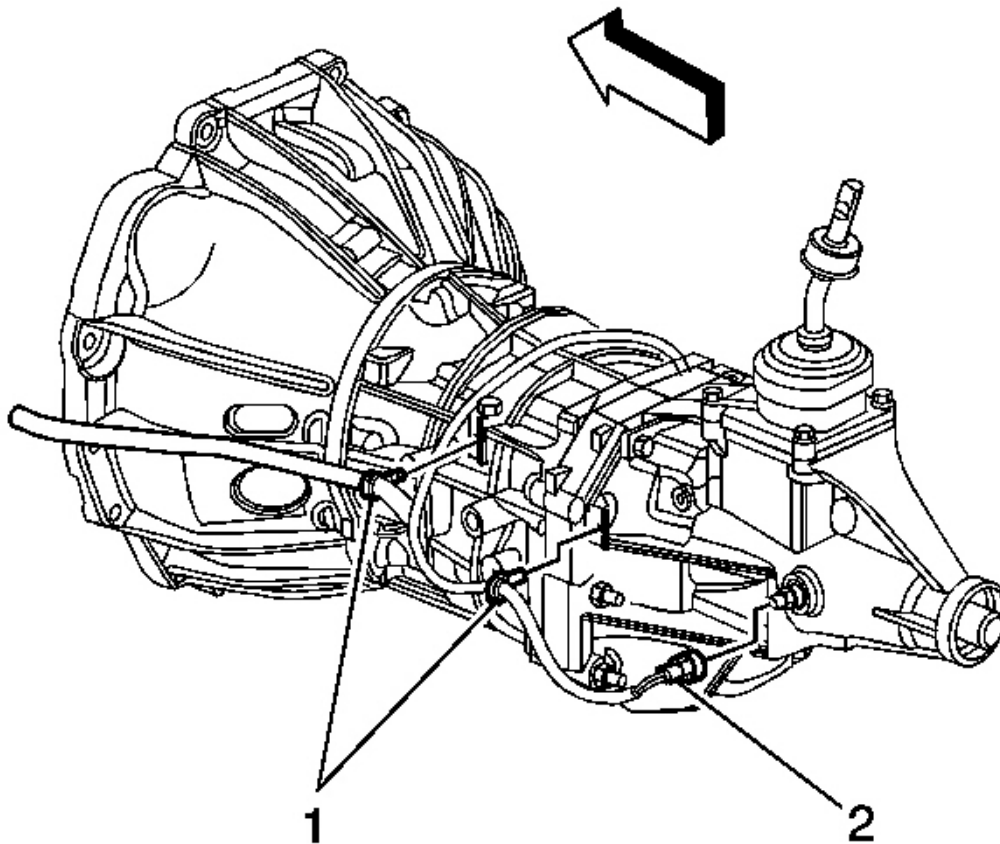

Fig. 18: View Of VSS Electrical Connector
Courtesy of GENERAL MOTORS CORP.

2. Disconnect the vehicle speed sensor (VSS) electrical connector (2).

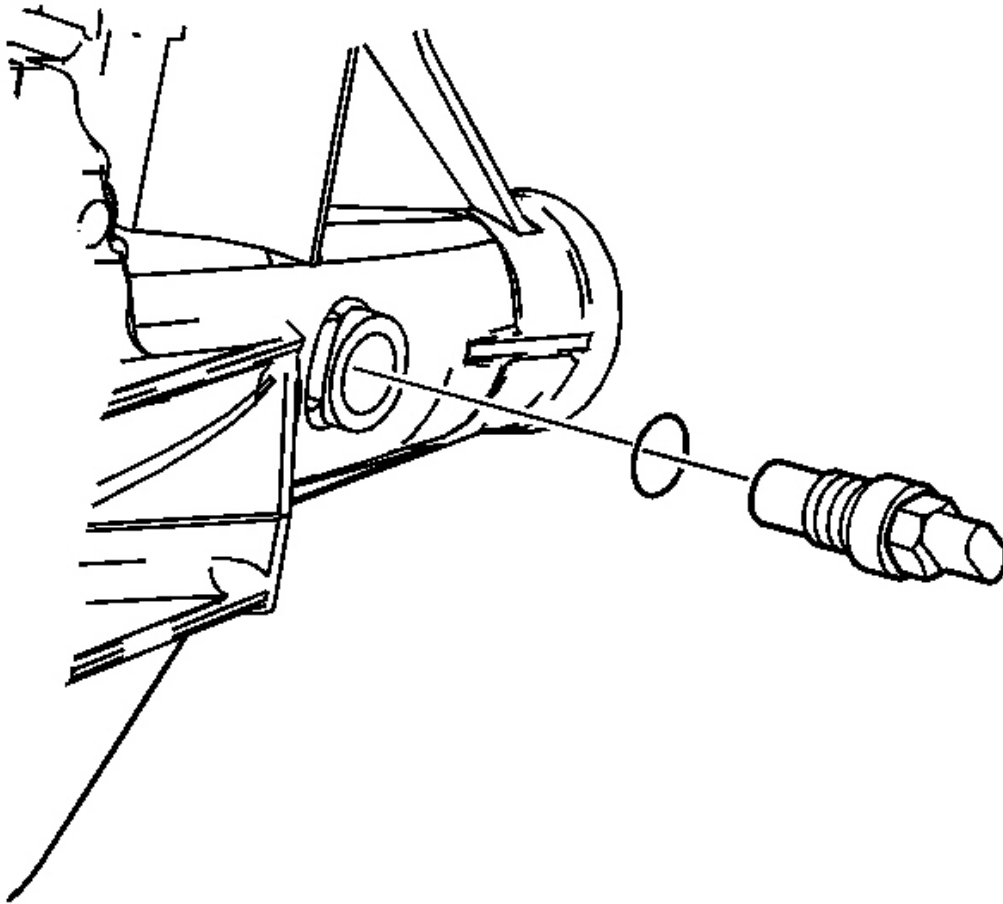

Fig. 19: View Of Vehicle Speed Sensor (VSS) With O-Ring Seal
Courtesy of GENERAL MOTORS CORP.

3. Remove the VSS with O-ring seal.

Installation Procedure

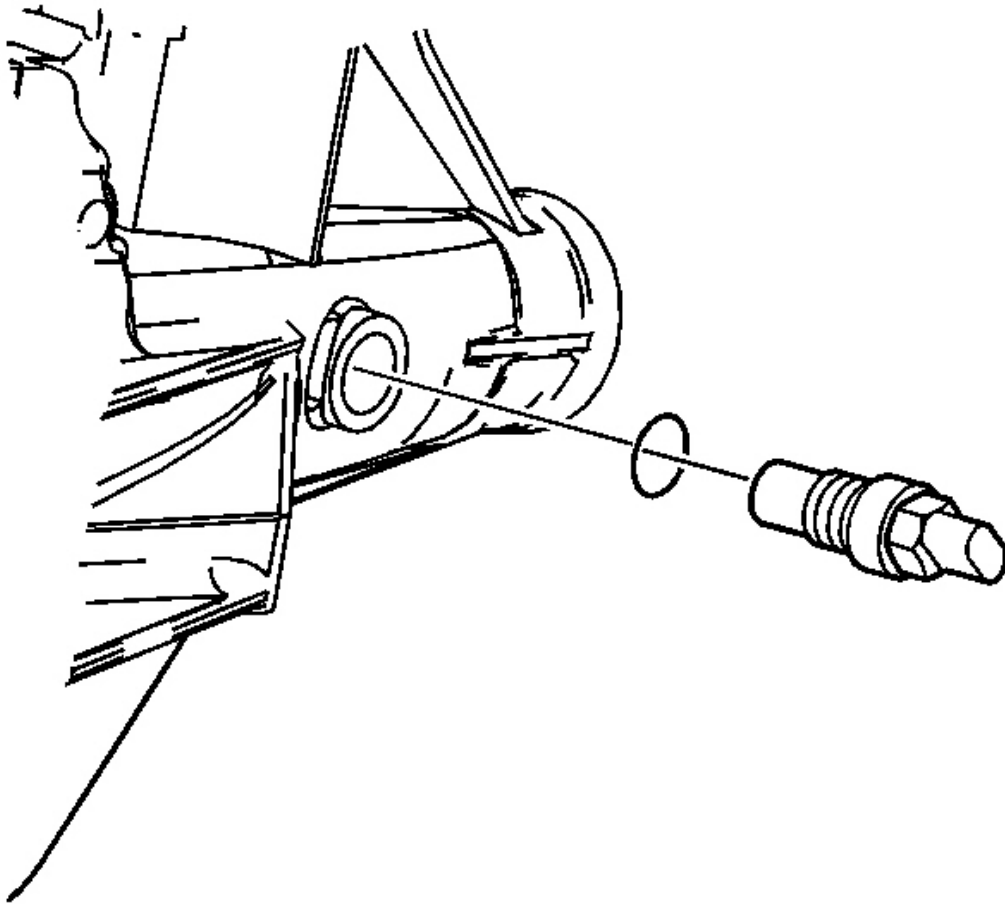

Fig. 20: View Of Vehicle Speed Sensor (VSS) With O-Ring Seal
Courtesy of GENERAL MOTORS CORP.

NOTE: Refer to Component Fastener Tightening Notice .

1. Install the VSS with O-ring seal.

Tighten: Tighten the vehicle speed sensor (VSS) to 17 N.m (13 lb ft).

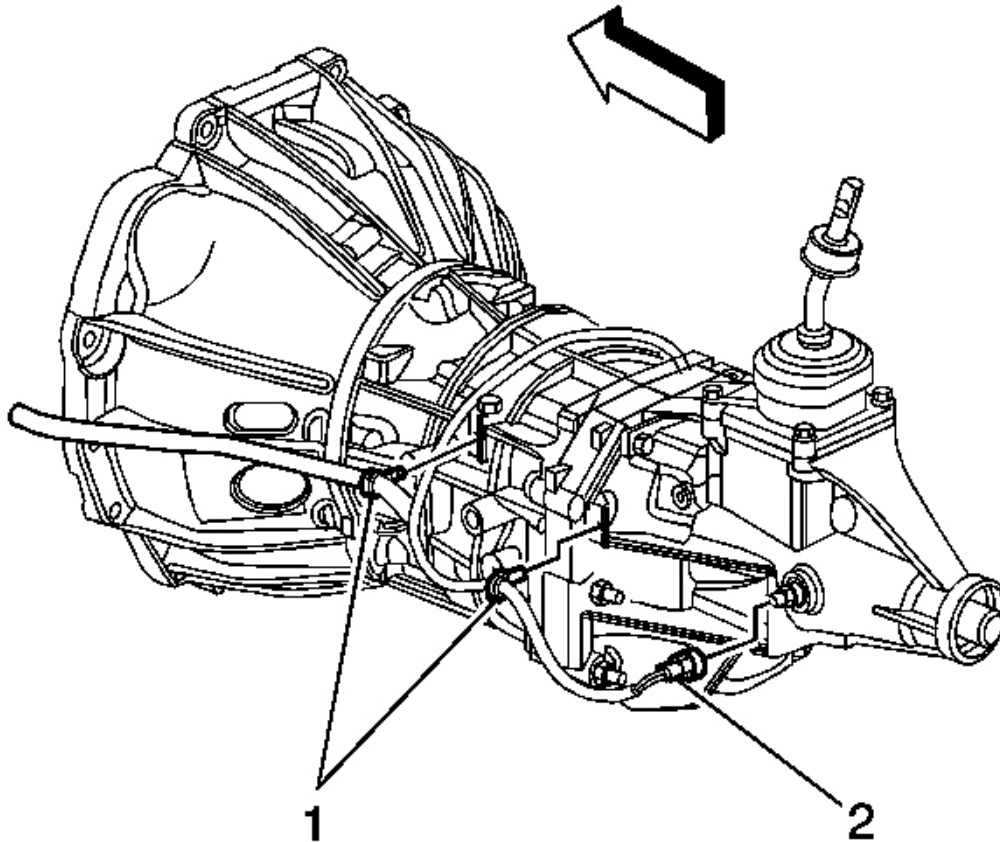

Fig. 21: View Of VSS Electrical Connector
Courtesy of GENERAL MOTORS CORP.

2. Connect the VSS electrical connector (2).
3. Lower the vehicle.

TRANSMISSION MOUNT REPLACEMENT

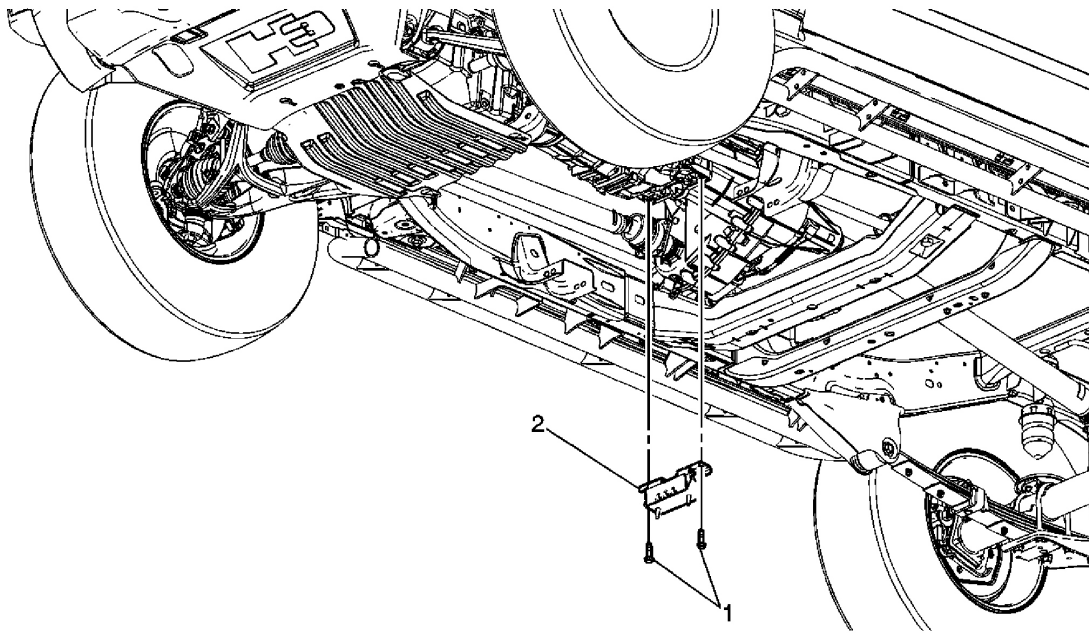

Fig. 22: Transmission Mount Replacement
 Courtesy of GENERAL MOTORS CORP.

Transmission Mount Replacement

Callout	Component Name
<p>Preliminary Procedures</p> <ol style="list-style-type: none"> 1. Raise the vehicle. Refer to <u>Lifting and Jacking the Vehicle</u> . 2. Remove the transfer case shield. Refer to <u>Transfer Case Shield Replacement</u> . 3. Remove the transmission crossmember. Refer to <u>Transmission Support Crossmember Replacement</u> . 	
1	Transmission Mount Bolt (Qty: 2) NOTE: Refer to <u>Fastener Notice</u> . Tighten: 50 N.m (37 lb in)
2	Transmission Mount

TRANSMISSION INPUT SHAFT BEARING RETAINER REPLACEMENT

Removal Procedure

1. Drain the transmission fluid. Refer to Transmission Fluid Replacement.
2. Remove the clutch actuator cylinder. Refer to Clutch Actuator Cylinder Replacement.

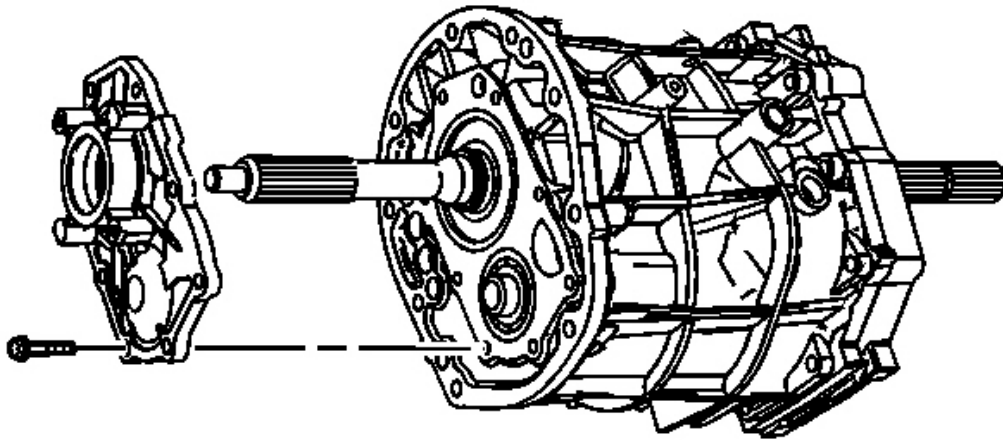

Fig. 23: Locating Input Shaft Bearing Retainer Bolts
Courtesy of GENERAL MOTORS CORP.

3. Remove the input shaft bearing retainer bolts.

Discard the bolts.
4. Remove the input shaft bearing retainer.
5. Clean and inspect the input shaft bearing retainer. Refer to Transmission Case Cleaning and Inspection.

Installation Procedure

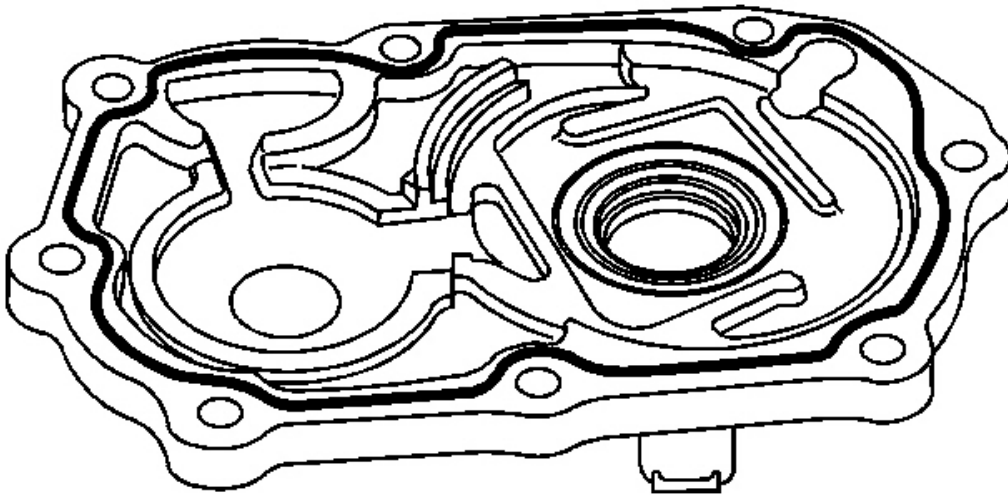

Fig. 24: Sealant Area On Input Shaft Bearing Retainer
Courtesy of GENERAL MOTORS CORP.

1. Apply a 3 mm (1/8 in) bead of sealant GM P/N 89020326 (Canadian P/N 89021188) to the input shaft bearing retainer.

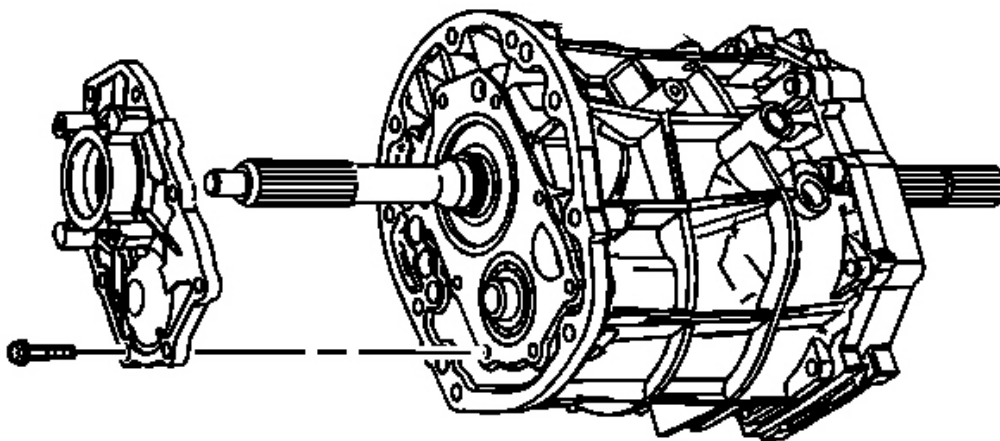

Fig. 25: Locating Input Shaft Bearing Retainer Bolts
Courtesy of GENERAL MOTORS CORP.

IMPORTANT: Ensure the seal does not catch on the input shaft splines.

2. Position the input shaft bearing retainer to the transmission.
3. Apply pipe sealant GM P/N 12346004 (Canadian P/N 10953480) to the threads of the input shaft bearing retainer bolts if new bolts are not available.

NOTE: Refer to Fastener Notice .

4. Install the NEW input shaft bearing retainer bolts.

Tighten: Tighten the input shaft bearing retainer bolts to 17 N.m (13 lb ft).

5. Install the clutch actuator cylinder. Refer to Clutch Actuator Cylinder Replacement .
6. Fill the transmission fluid. Refer to Transmission Fluid Replacement.

TRANSMISSION INPUT SHAFT SEAL REPLACEMENT

Tools Required

J 45866 Input Shaft Seal Installer. See Special Tools.

Removal Procedure

1. Remove the transmission input shaft bearing retainer. Refer to Transmission Input Shaft Bearing Retainer Replacement.

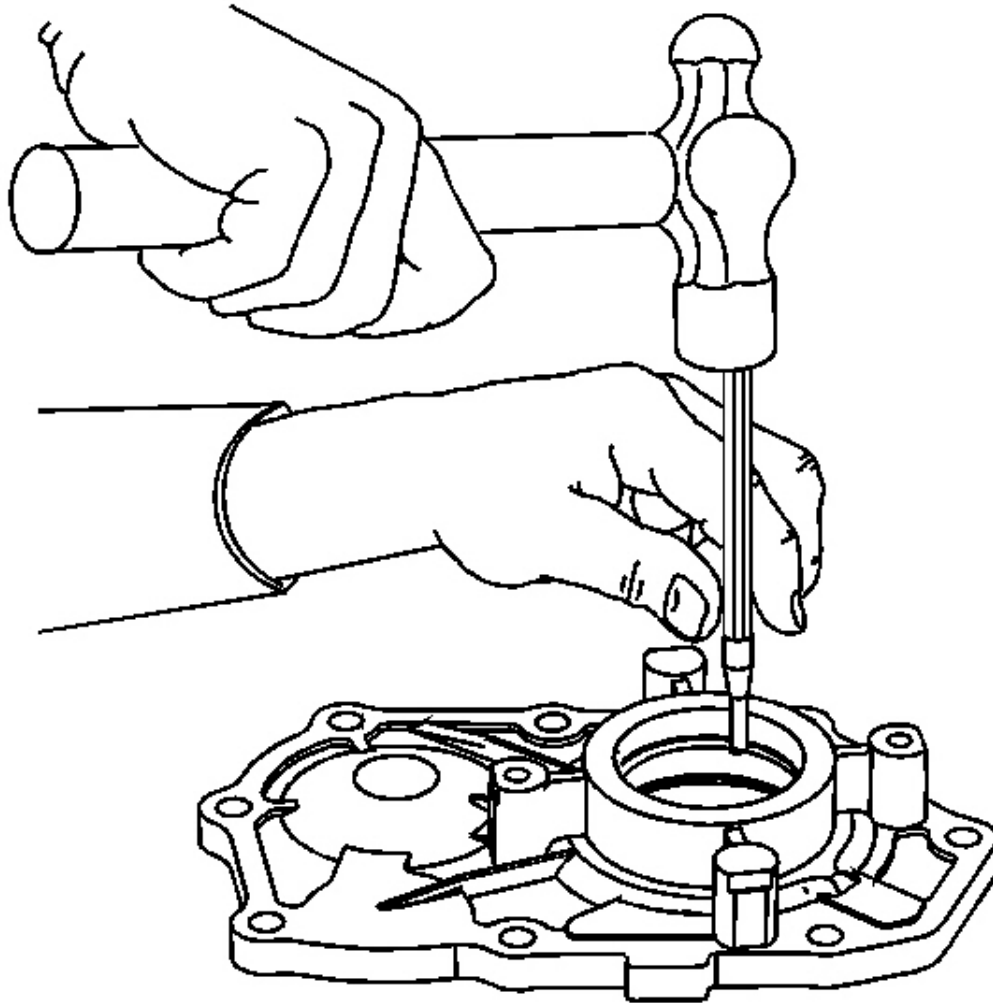

Fig. 26: Removing/Installing Input Shaft Seal
Courtesy of GENERAL MOTORS CORP.

2. Using a hammer and a punch, remove the input shaft seal from the input shaft bearing retainer.

Installation Procedure

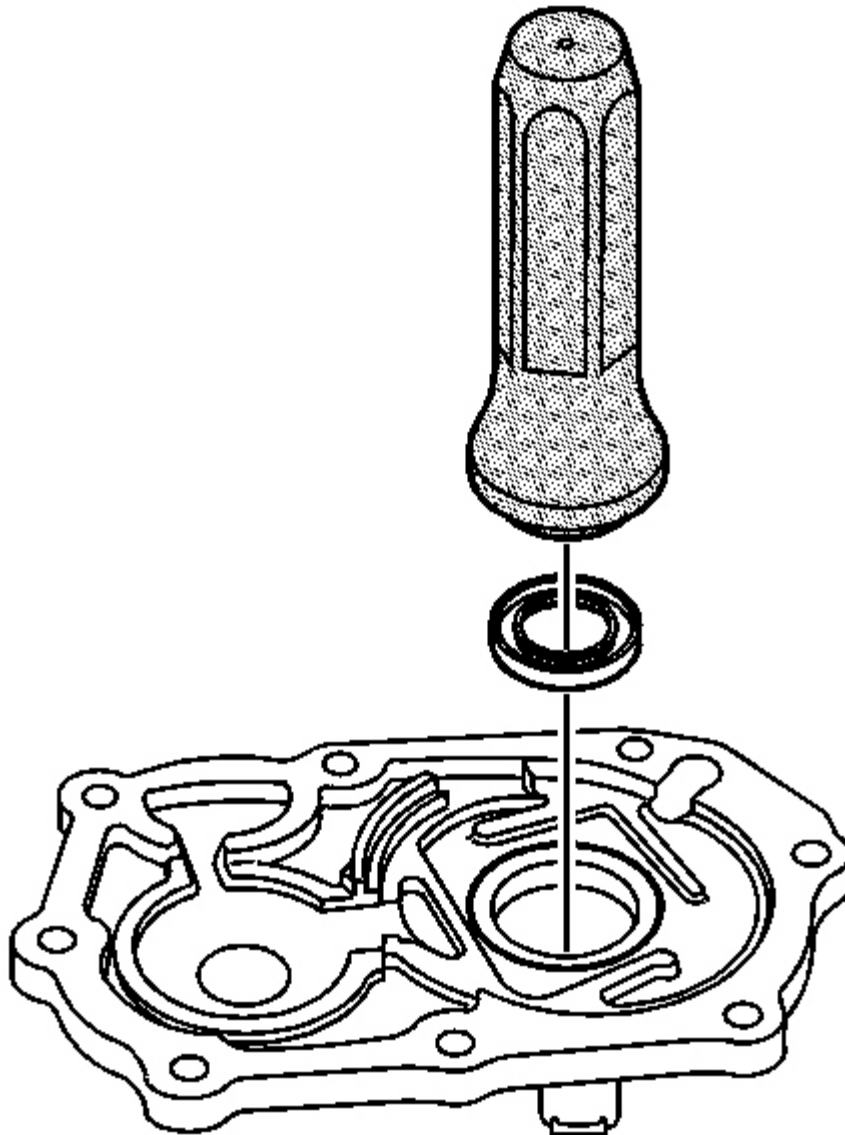

Fig. 27: View Of Input Shaft Seal
Courtesy of GENERAL MOTORS CORP.

1. Using the **J 45866** and a hammer, install the input shaft seal into the input shaft bearing retainer. See **Special Tools**.
 - The spring side of the seal goes toward the tool

- Ensure the seal is installed square
 - The tool will install the seal to the correct depth
2. Install the transmission input shaft bearing retainer. Refer to **Transmission Input Shaft Bearing Retainer Replacement**.

TRANSMISSION HOUSING OIL SEAL REPLACEMENT - REAR

Tools Required

- **J 6125-1B** Slide Hammer
- **J 23129** Universal Seal Remover. See **Special Tools**.
- **J 45867** 4WD Output Shaft Seal Installer. See **Special Tools**.

Removal Procedure

1. Remove the transfer case assembly. Refer to **Transfer Case Assembly Replacement** .

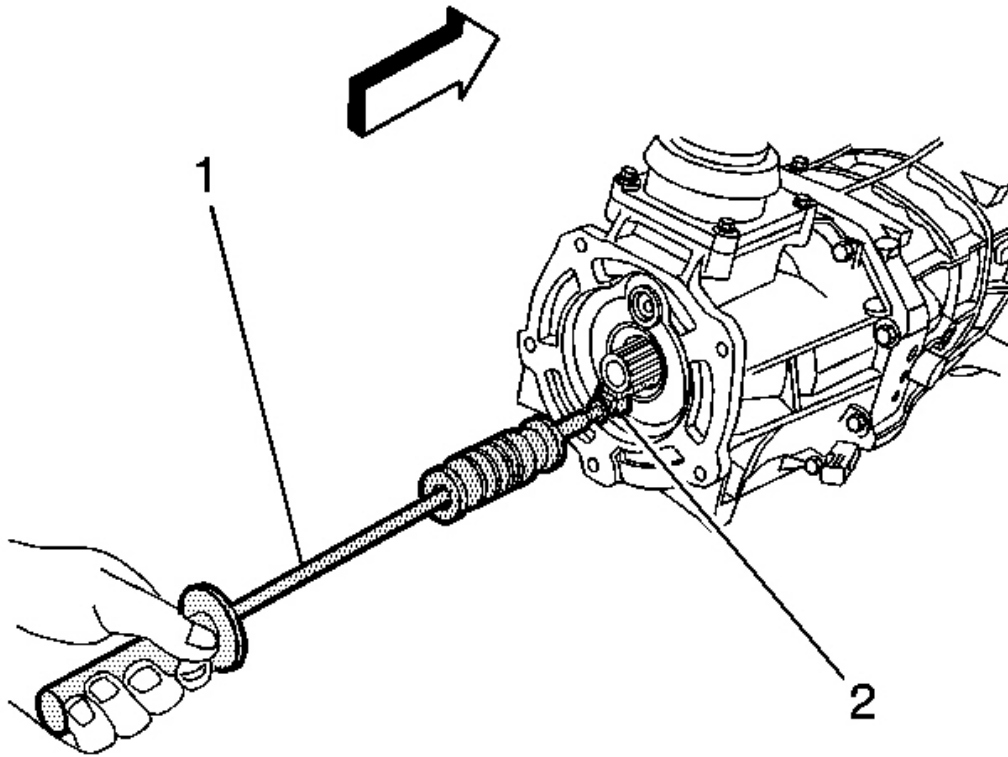

Fig. 28: Removing Rear Transmission Housing Oil Seal - 4WD
Courtesy of GENERAL MOTORS CORP.

2. Using the **J 6125-1B** (1) and **J 23129** (2) remove the rear transmission housing oil seal from the housing. See **Special Tools**.

Installation Procedure

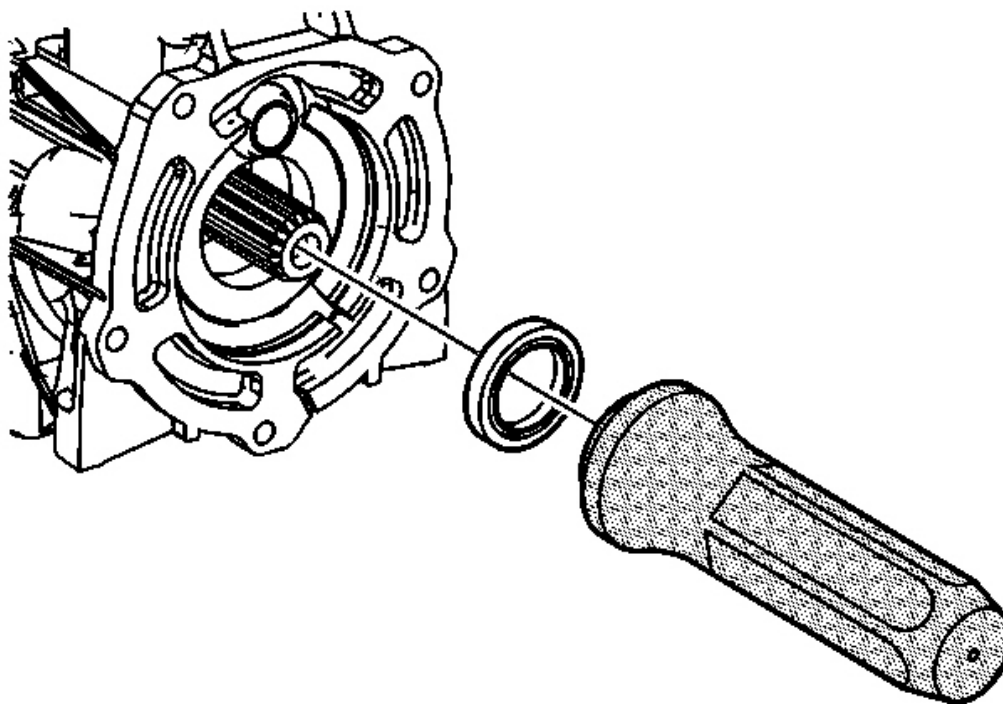

Fig. 29: Identifying Output Shaft Seal - 4WD
Courtesy of GENERAL MOTORS CORP.

1. Using the **J 45867** and a hammer, install the NEW rear transmission housing oil seal. See **Special Tools**.
2. Check the transmission fluid level. Add if necessary. Refer to **Transmission Fluid Replacement**.
3. Install the transfer case assembly. Refer to **Transfer Case Assembly Replacement** .

BACKUP LAMP SWITCH REPLACEMENT

Removal Procedure

1. Raise and support the vehicle. Refer to **Lifting and Jacking the Vehicle** .

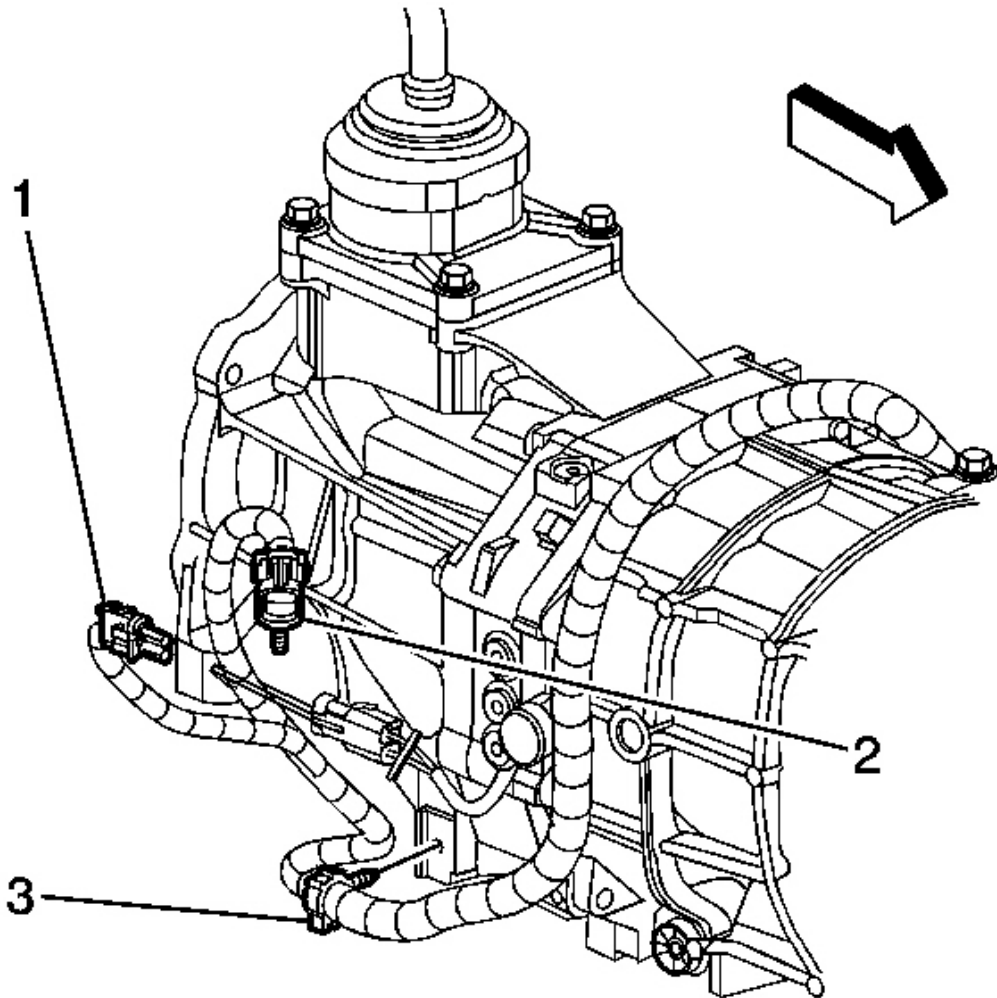

Fig. 30: View Of Backup Lamp Switch Electrical Connector & Oxygen Sensor
Courtesy of GENERAL MOTORS CORP.

2. Disconnect the backup lamp switch electrical connector (1) at the pigtail.
3. Open the tie strap securing the pigtail to the transmission.

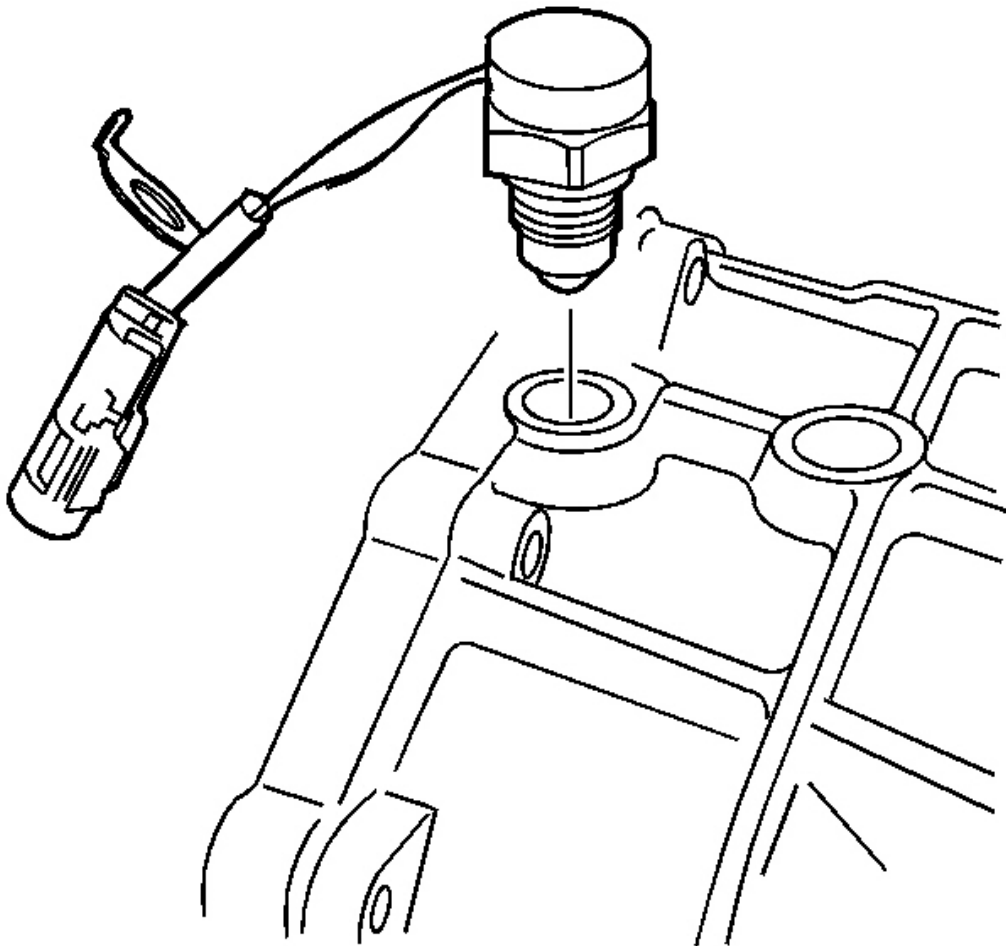

Fig. 31: View Of Backup Lamp Switch
Courtesy of GENERAL MOTORS CORP.

4. Remove the backup lamp switch with the aluminum washer.

Installation Procedure

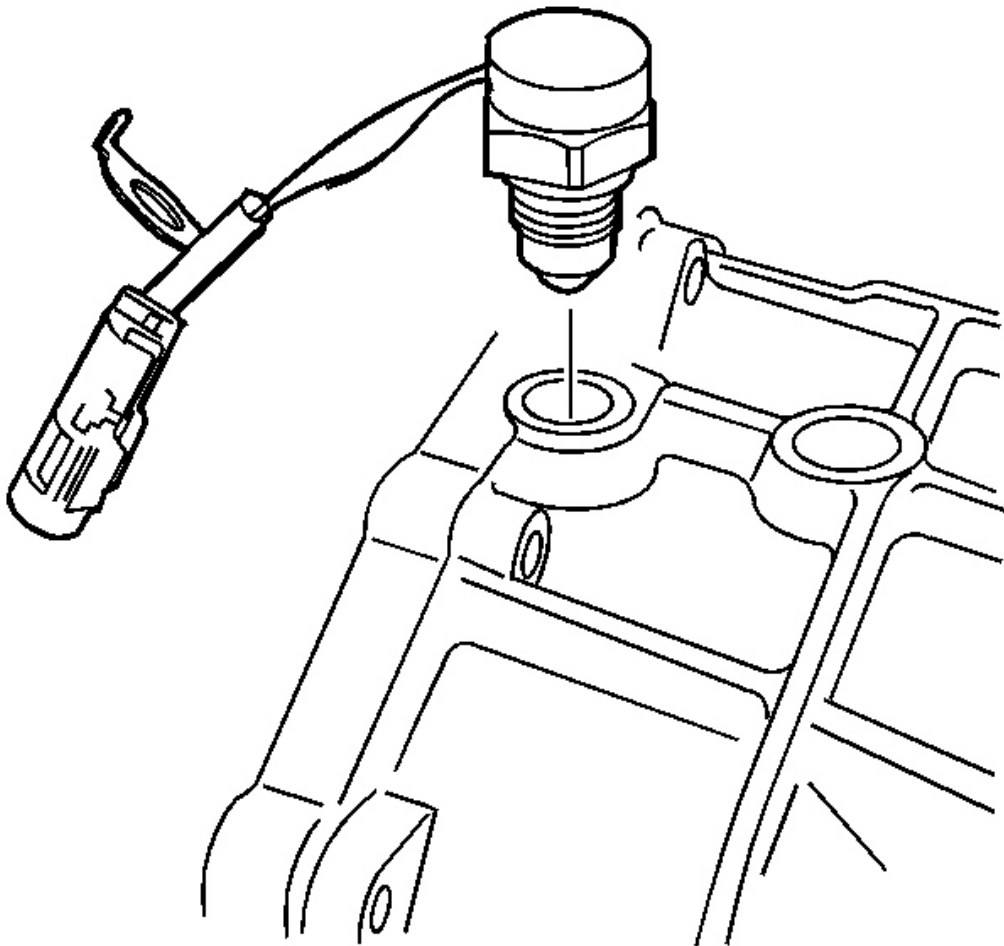

Fig. 32: View Of Backup Lamp Switch
Courtesy of GENERAL MOTORS CORP.

NOTE: Refer to Component Fastener Tightening Notice .

1. Install the backup lamp switch with a NEW aluminum washer into the transmission case.

Tighten: Tighten the backup lamp switch to 44 N.m (32 lb ft).

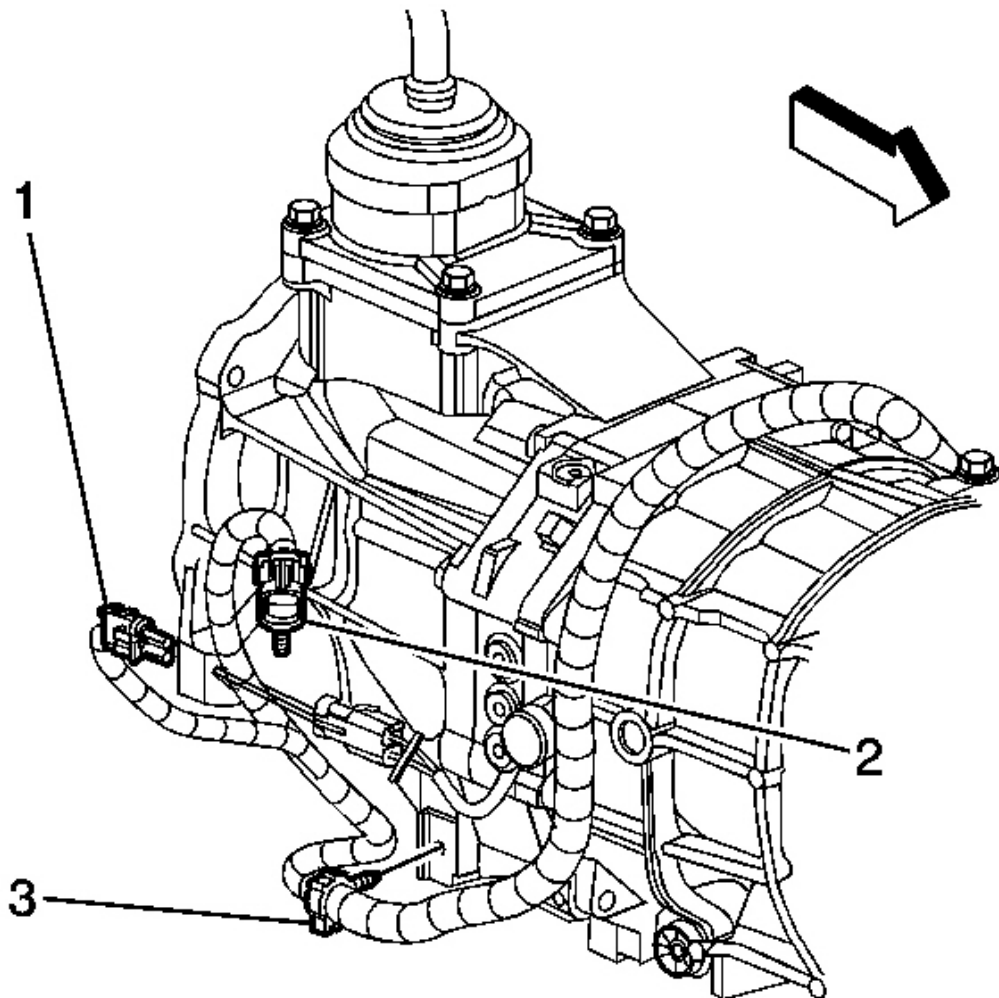

Fig. 33: View Of Backup Lamp Switch Electrical Connector & Oxygen Sensor
Courtesy of GENERAL MOTORS CORP.

2. Secure the pigtail to the transmission with the tie strap.
3. Connect the backup lamp switch electrical connector (1) at the pigtail.
4. Lower the vehicle.

TRANSMISSION REPLACEMENT

Tools Required

J 42371 Hydraulic Clutch Line Separator

Removal Procedure

1. Remove the control lever and boot. Refer to Control Lever and/or Boot Replacement.
2. Drain the transmission fluid if necessary. Refer to Transmission Fluid Replacement.
3. Remove the transfer case assembly. Refer to Transfer Case Assembly Replacement.

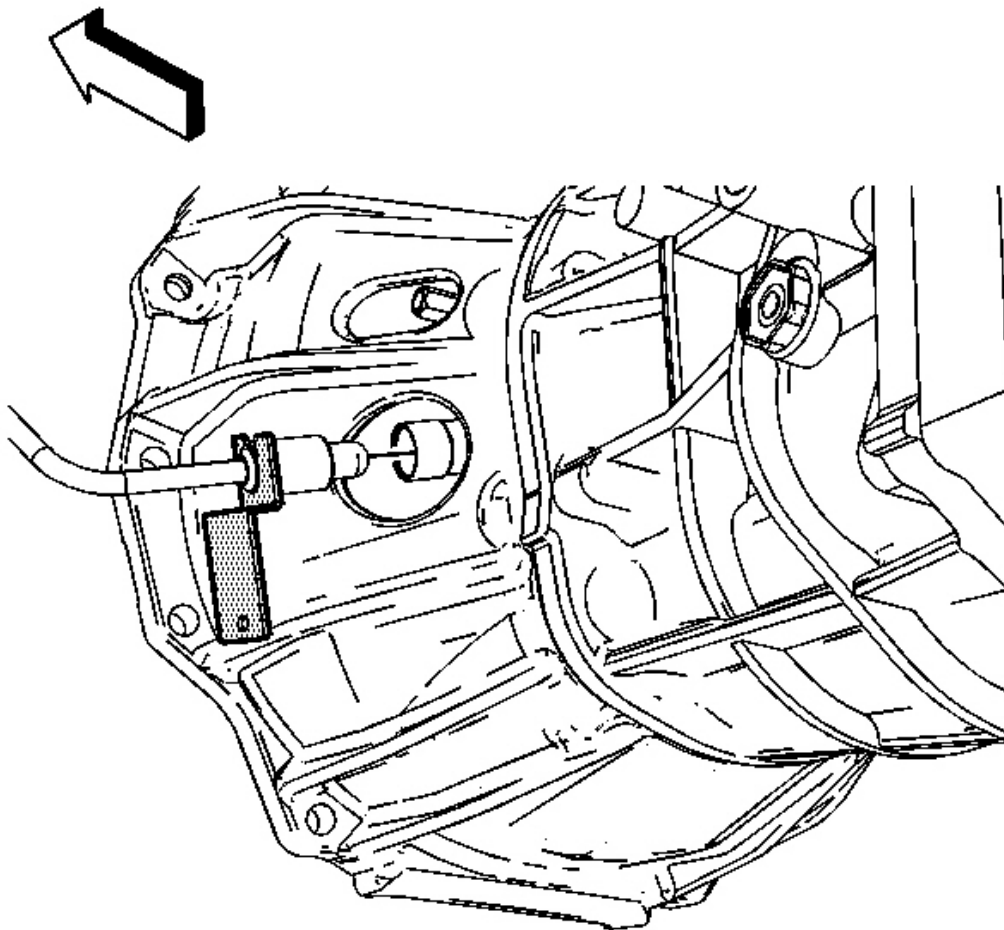

Fig. 34: Separating Hydraulic Clutch Line From Clutch Actuator Quick Connect
Courtesy of GENERAL MOTORS CORP.

4. Using the J 42371 push back on the white plastic sleeve on the quick connect in order to

separate the hydraulic clutch line from the clutch actuator quick connect.

It is not necessary to plug the lower hose end or slave cylinder fitting as they are equipped with check valves, only minimal fluid loss may be experienced.

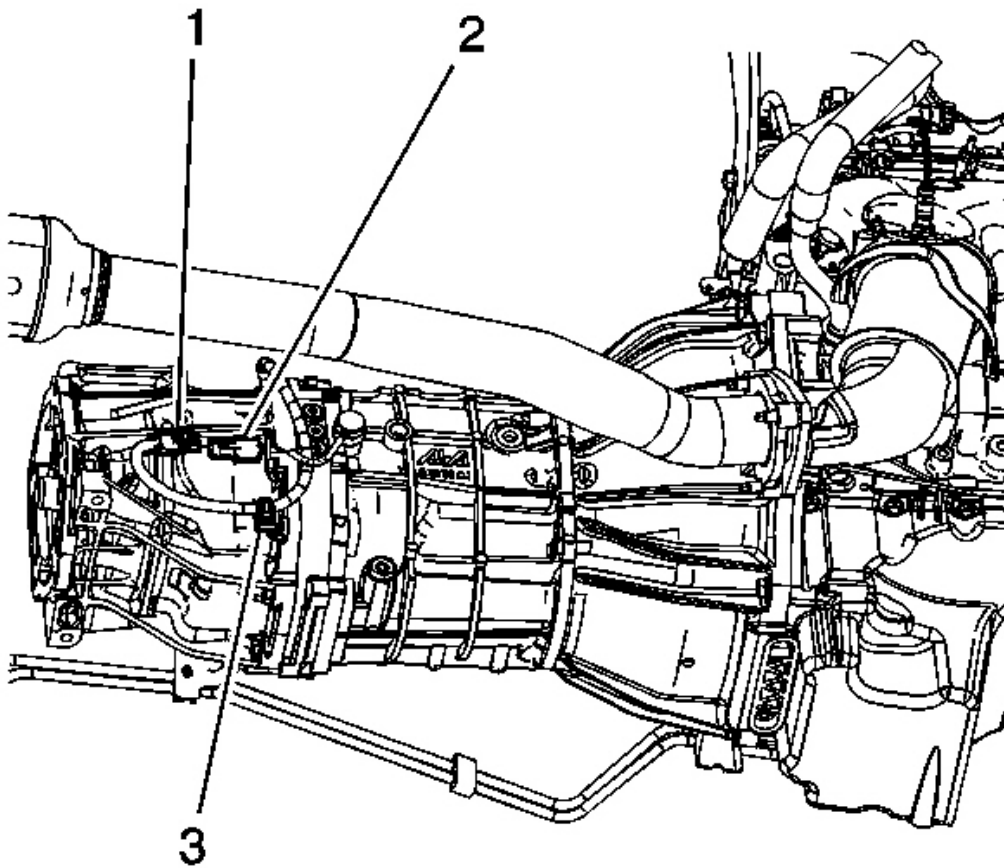

Fig. 35: Identifying Engine Wiring Harness Electrical Connector At Backup Lamp Switch

Courtesy of GENERAL MOTORS CORP.

5. Disconnect the engine wiring harness electrical connector (1) from the backup lamp switch (2).
6. Disconnect the engine wiring harness clip (3) from the clip bracket and position the harness over the transmission.

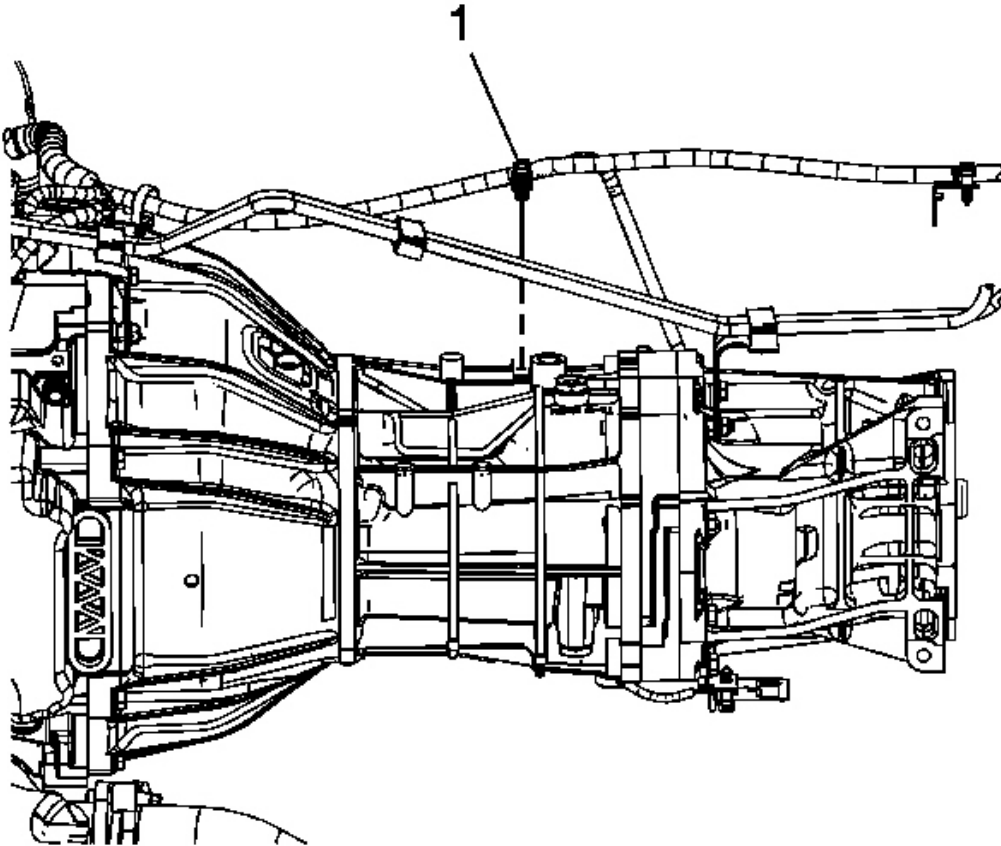

Fig. 36: Locating Wiring Harness Clip
Courtesy of GENERAL MOTORS CORP.

7. Disconnect the engine wiring harness clip (1) from the clip brackets and position the harness aside.

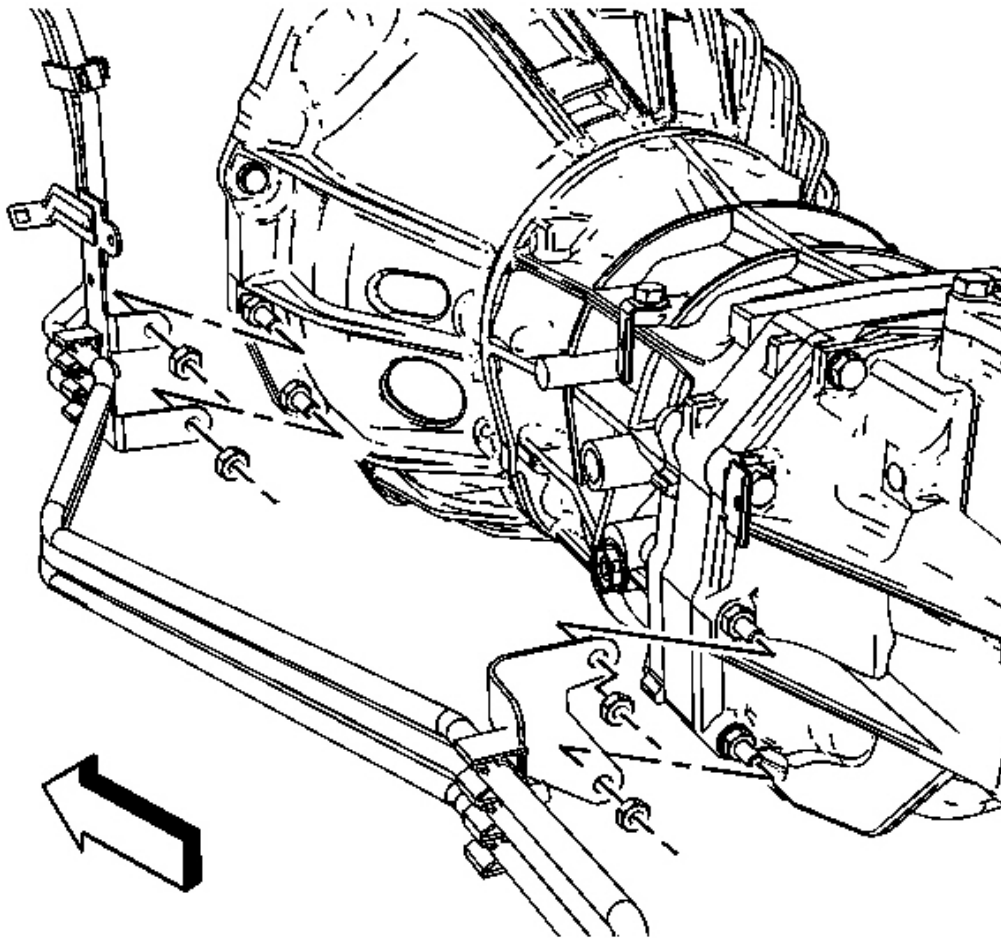

Fig. 37: View Of Fuel Hose/Pipe Bracket & Nuts (MA5)
Courtesy of GENERAL MOTORS CORP.

8. Remove the nuts securing the fuel hose/pipe brackets to the transmission and position aside.
9. Support and secure the transmission using a suitable transmission jack.
10. Remove the transmission crossmember. Refer to **Transmission Support Crossmember Replacement** .

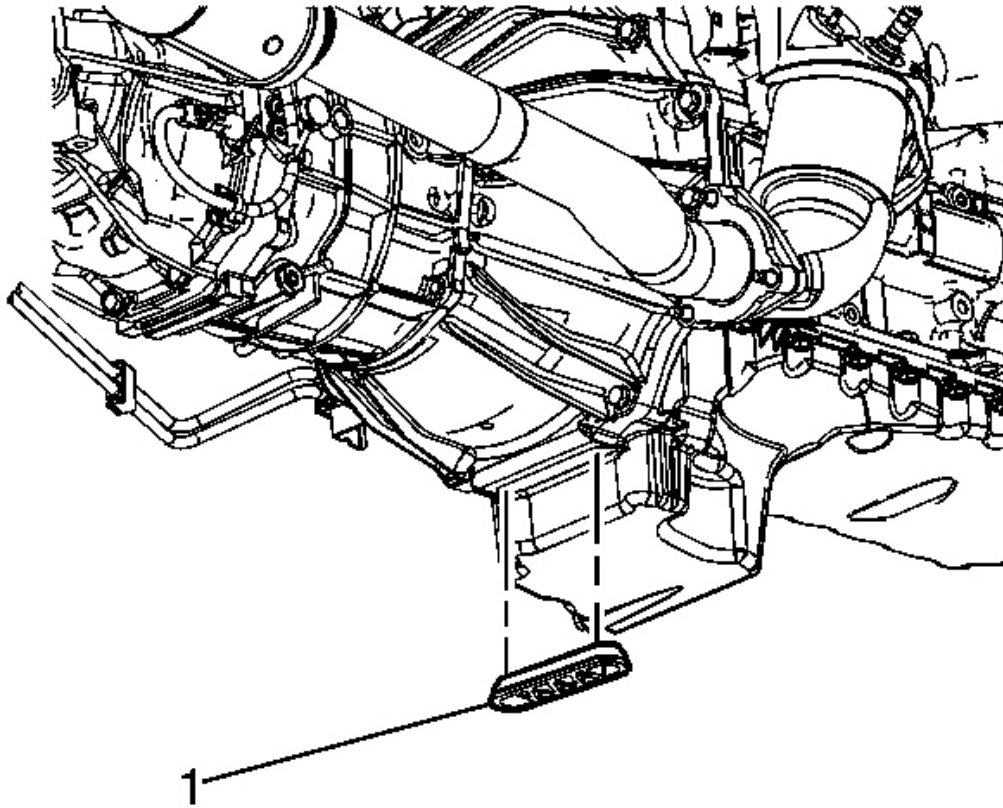

Fig. 38: Removing/Installing Service Slot Plug
Courtesy of GENERAL MOTORS CORP.

11. Remove the service slot plug (1).

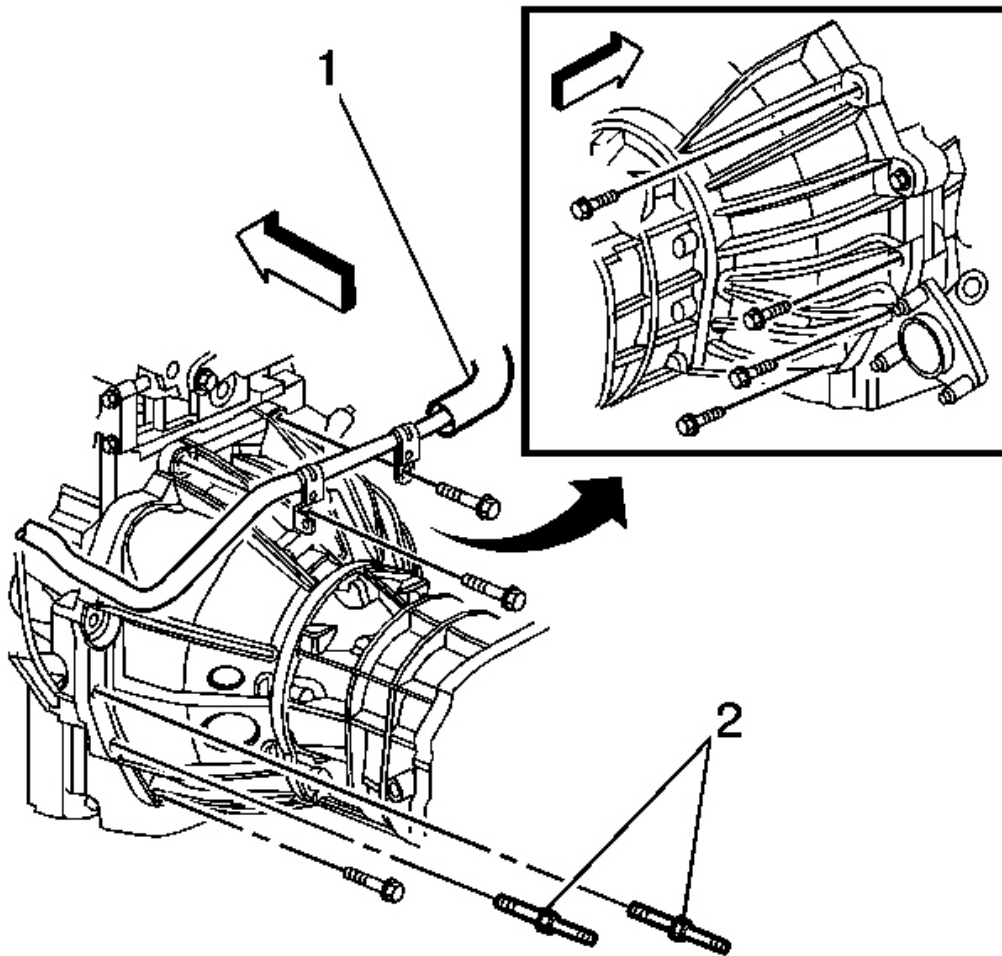

Fig. 39: View Of Transmission Mounting Bolts
Courtesy of GENERAL MOTORS CORP.

12. Remove the 7 transmission mounting bolts and 2 studded mounting bolts (2).

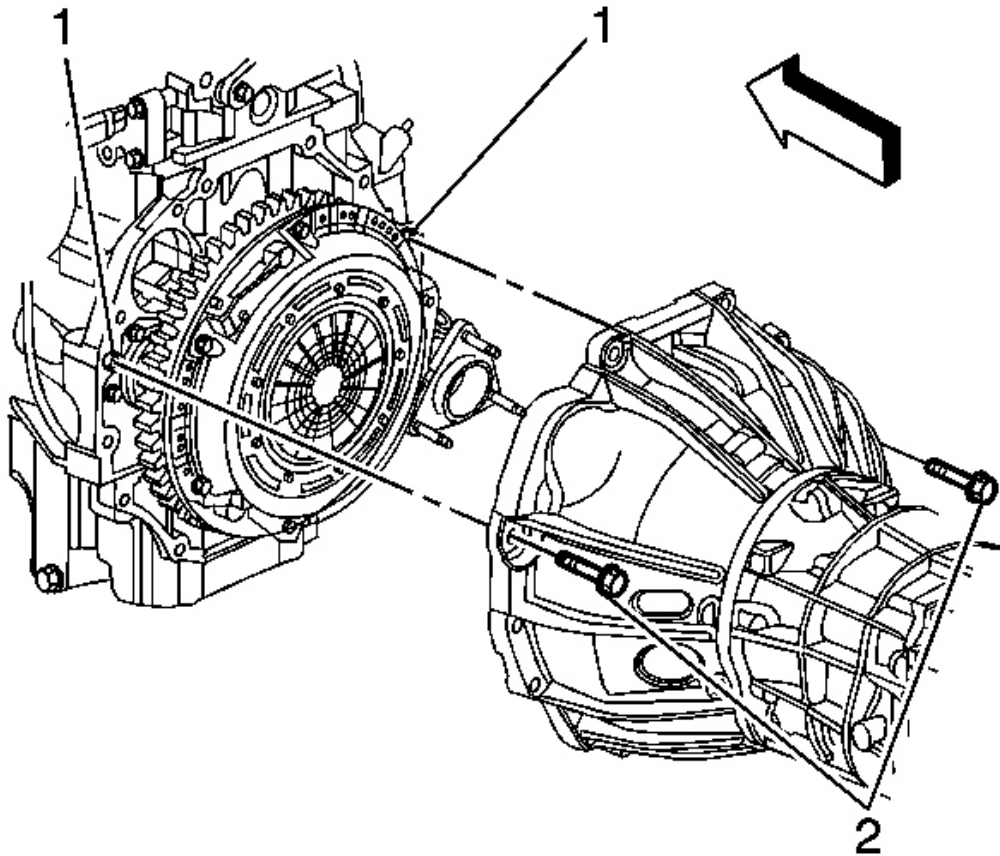

Fig. 40: View Of Transmission Mounting Bolts & Engine Dowels
Courtesy of GENERAL MOTORS CORP.

13. Remove the remaining transmission mounting bolts (2).

IMPORTANT: Do not allow the transmission to hang from the clutch assembly.

14. Pull the transmission straight back off the clutch hub splines.

IMPORTANT: Ensure clearance is maintained between the transmission and the following:

- The catalytic converter

- **The clutch assembly**
- **The engine wiring harness**
- **The fuel hose/pipe brackets**
- **The heater pipe**

15. Using the transmission jack, carefully lower the transmission from the vehicle.

Installation Procedure

IMPORTANT: Ensure clearance is maintained between the transmission and the following:

- **The catalytic converter**
- **The clutch assembly**
- **The engine wiring harness**
- **The fuel hose/pipe brackets**
- **The heater pipe**

1. Using the transmission jack, carefully raise the transmission to the engine.

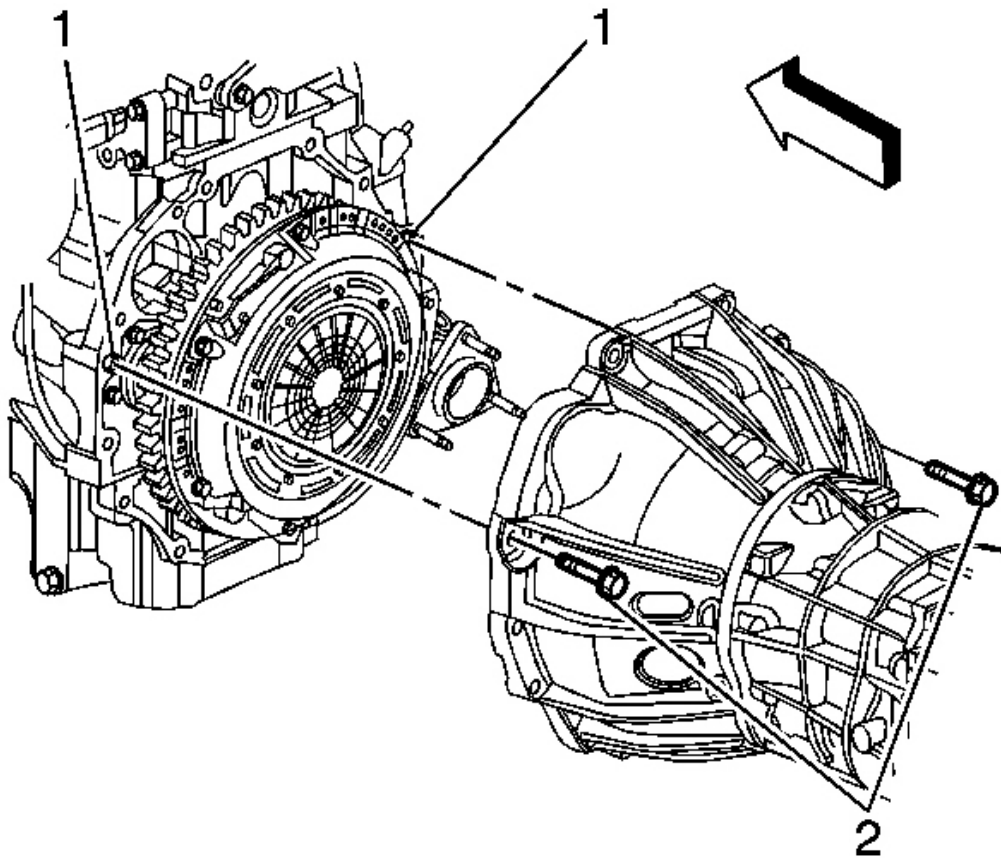

Fig. 41: View Of Transmission Mounting Bolts & Engine Dowels
Courtesy of GENERAL MOTORS CORP.

IMPORTANT: Do not allow the transmission to hang from the clutch assembly.

2. Align the transmission with the engine dowels (1).

NOTE: Refer to Fastener Notice .

3. Install the 2 transmission mounting bolts (2).

Tighten: Tighten the transmission mounting bolts to 50 N.m (37 lb ft).

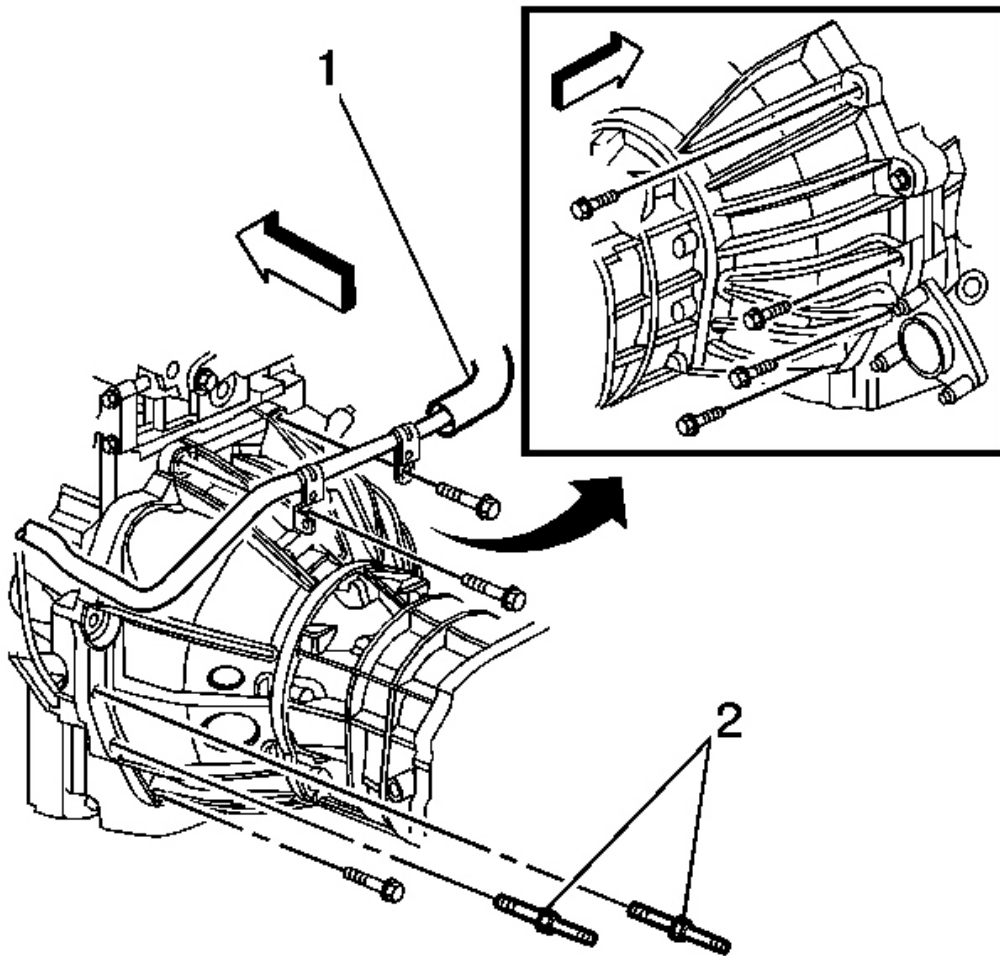

Fig. 42: View Of Transmission Mounting Bolts
Courtesy of GENERAL MOTORS CORP.

IMPORTANT:

- Ensure the studded mounting bolts (2) are located in the correct position.
- The heater pipe (1) must be secured with the 2 upper mounting bolts.

4. Install the remaining transmission mounting bolts.

Tighten: Tighten the transmission mounting bolts to 50 N.m (37 lb ft).

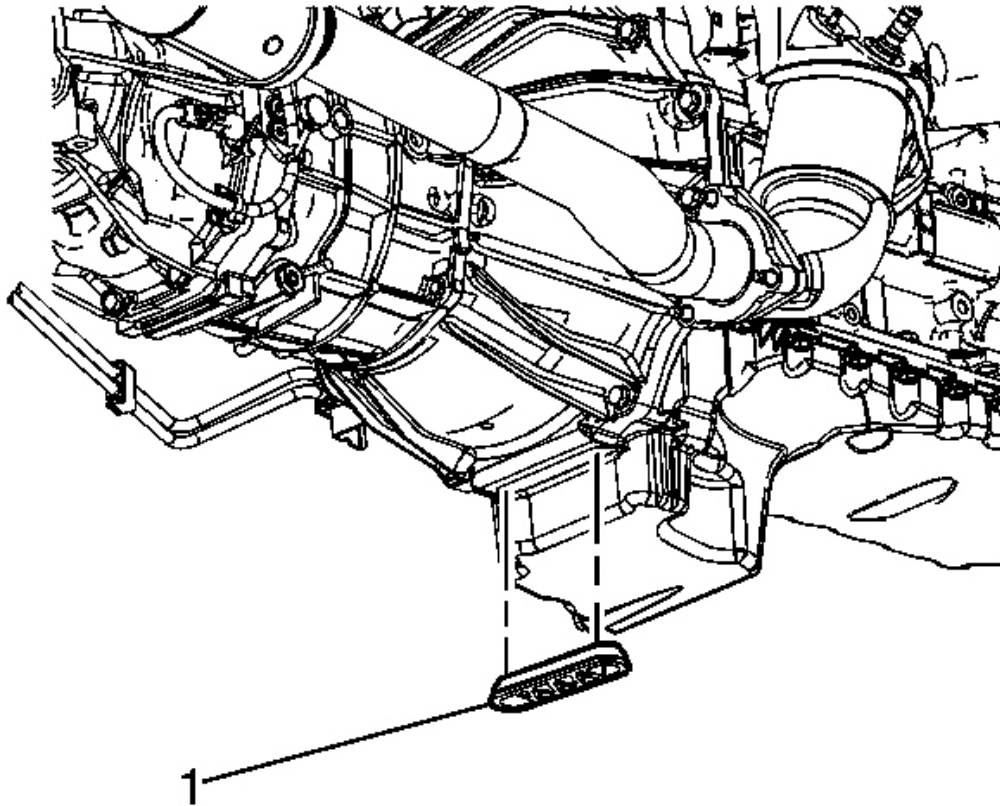

Fig. 43: Removing/Installing Service Slot Plug
Courtesy of GENERAL MOTORS CORP.

5. Install the service slot plug (1).
6. Install the transmission crossmember. Refer to **Transmission Support Crossmember Replacement** .
7. Remove the transmission jack from under the vehicle.

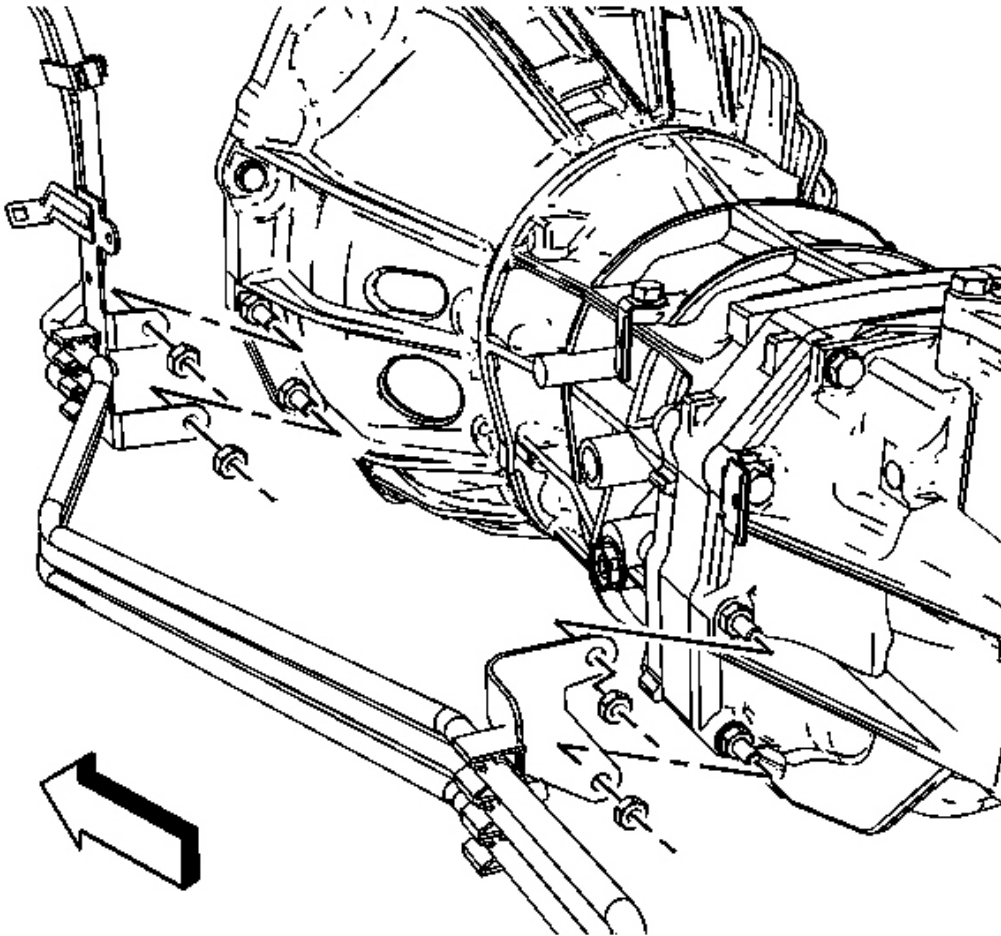

Fig. 44: View Of Fuel Hose/Pipe Bracket & Nuts (MA5)
Courtesy of GENERAL MOTORS CORP.

8. Install the nuts securing the fuel hose/pipe brackets to the transmission.

Tighten: Tighten the fuel hose/pipe brackets nuts to 20 N.m (15 lb ft).

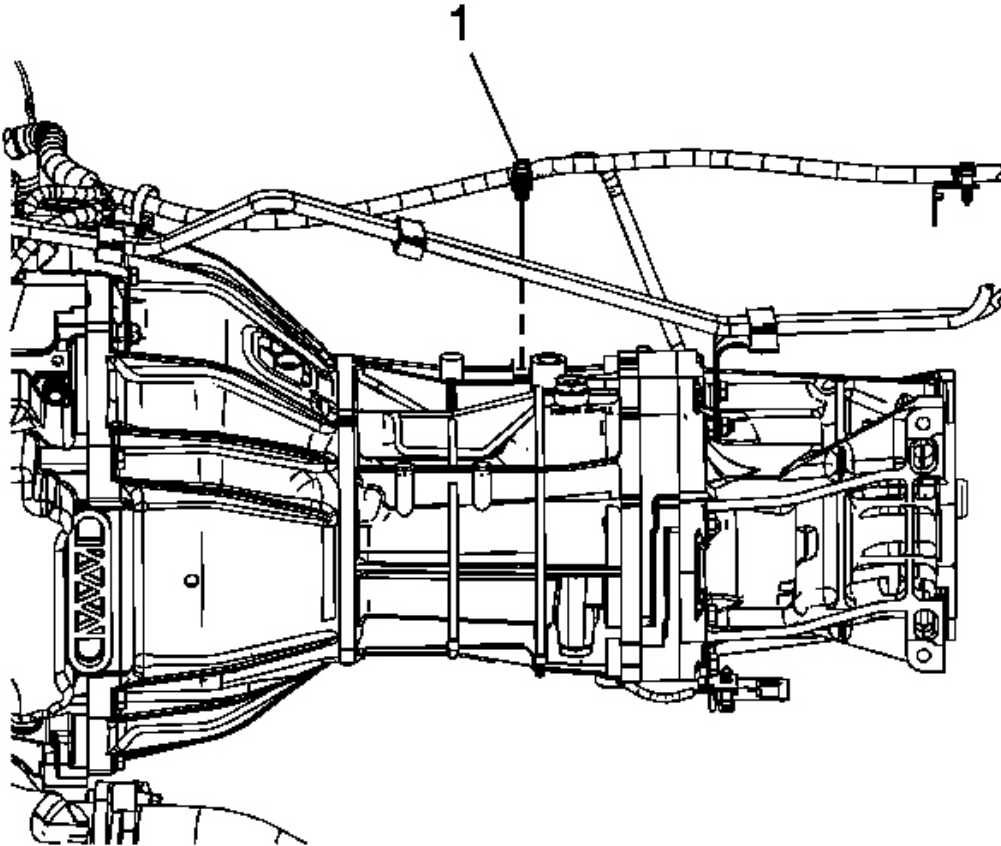

Fig. 45: Locating Wiring Harness Clip
Courtesy of GENERAL MOTORS CORP.

9. Connect the engine wiring harness clip (1) to the clip brackets.
10. Lay the engine wiring harness over the transmission.

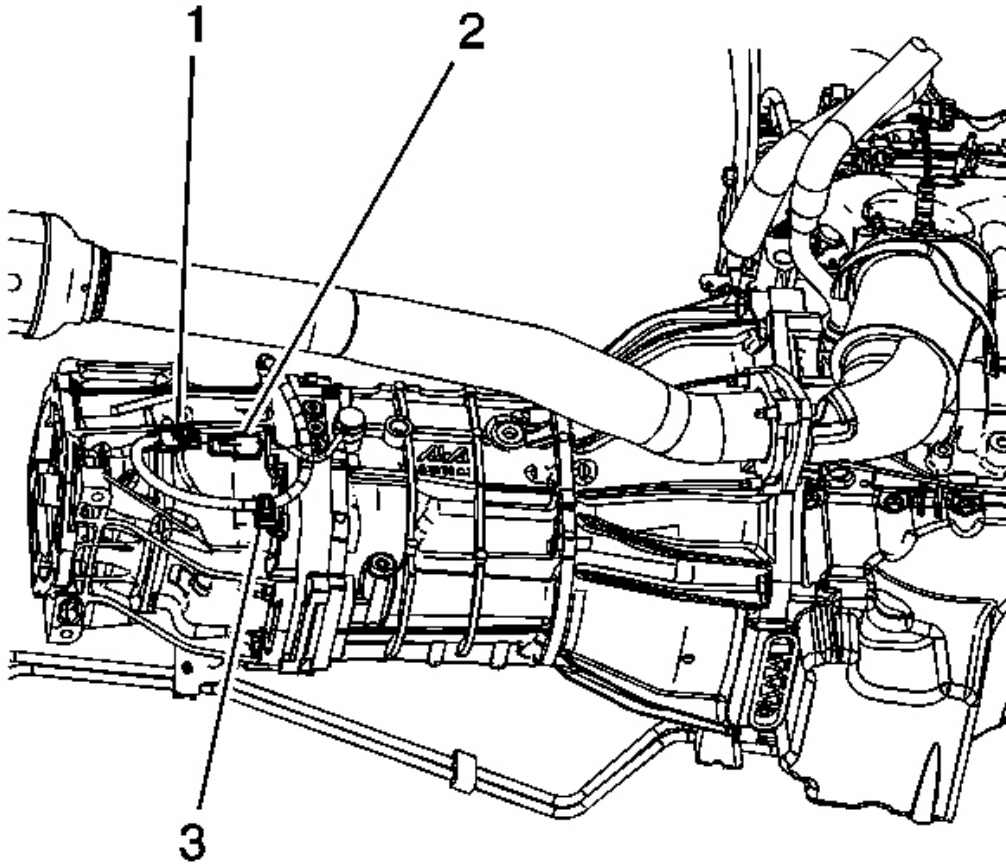

Fig. 46: Identifying Engine Wiring Harness Electrical Connector At Backup Lamp Switch

Courtesy of GENERAL MOTORS CORP.

11. Connect the engine wiring harness electrical connector (1) to the backup lamp switch (2).
12. Connect the engine wiring harness clip (3) to the clip bracket.

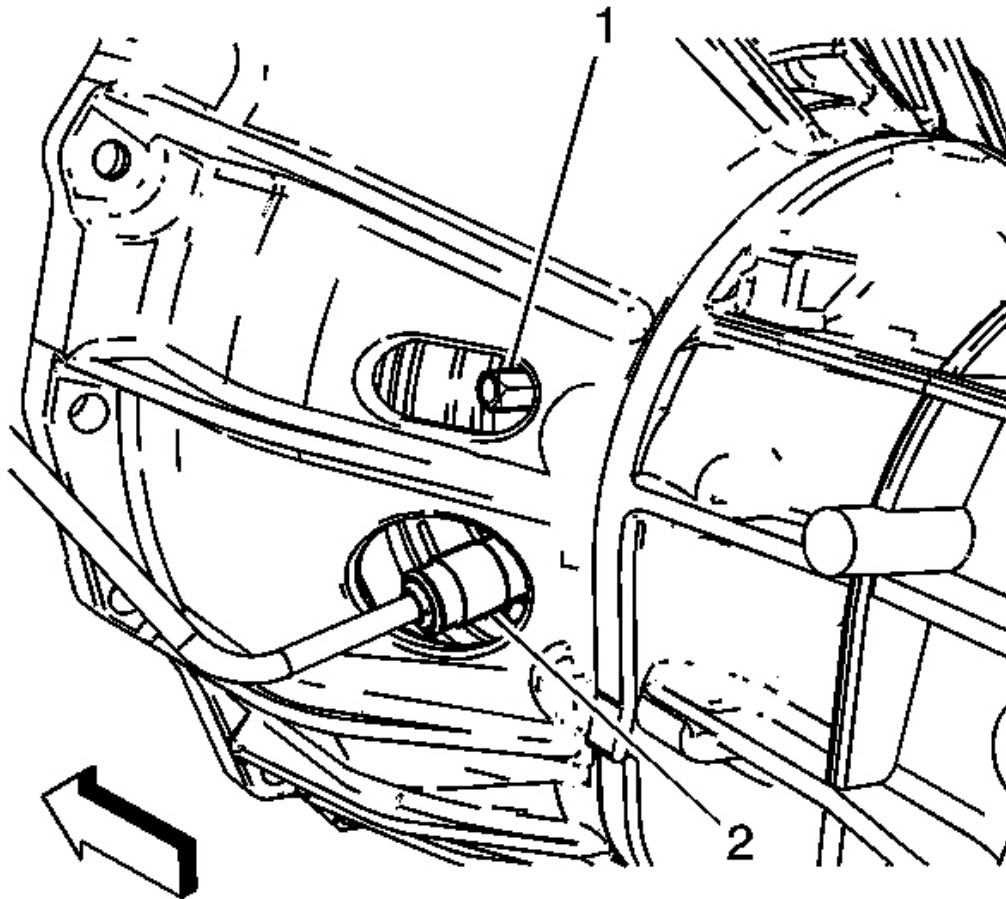

Fig. 47: View Of Clutch Hydraulic Hose Quick Connect Fitting
Courtesy of GENERAL MOTORS CORP.

IMPORTANT: Ensure the clutch hydraulic hose does not come in contact with any sharp or potential hot surfaces.

13. Push the clutch hydraulic hose quick connect fitting (2) into the clutch slave cylinder, until a "click" is heard.
14. Tug gently on the clutch hydraulic hose to ensure proper retention into the clutch slave cylinder.
15. Install the transfer case assembly. Refer to **Transfer Case Assembly Replacement** .
16. Fill the transmission fluid if removed. Refer to **Transmission Fluid Replacement**.

17. Install the control lever and boot. Refer to **Control Lever and/or Boot Replacement**.

Transmission Final Test and Inspection

Complete the following procedure after the transmission is installed in the vehicle:

1. With the ignition OFF or disconnected and clutch pedal depressed, crank the engine several times. Listen for any unusual noises or evidence that any parts are binding.
2. Place the transmission in neutral, start the engine and listen for any unusual noises or evidence that any parts are binding.
3. Turn OFF the ignition.
4. Perform a final inspection for the proper fluid level. Refer to **Transmission Fluid Replacement**.
5. Road test the vehicle.

REPAIR INSTRUCTIONS - OFF VEHICLE

TRANSMISSION DISASSEMBLE

Tools Required

J 8433 Two Jaw Puller

Disassembly Procedure

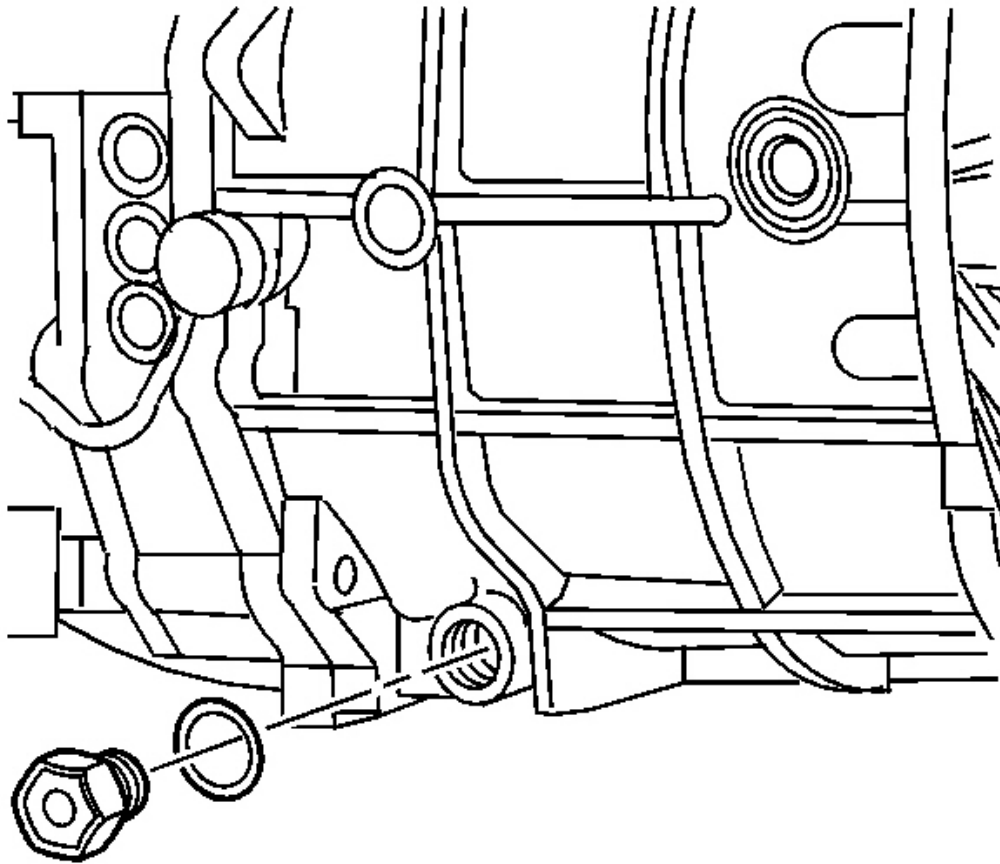

Fig. 48: View Of Drain Plug
Courtesy of GENERAL MOTORS CORP.

IMPORTANT: The following steps apply to both the 4WD and the RWD transmission, except where noted.

1. Remove the drain plug, with aluminum washer and drain the transmission fluid.

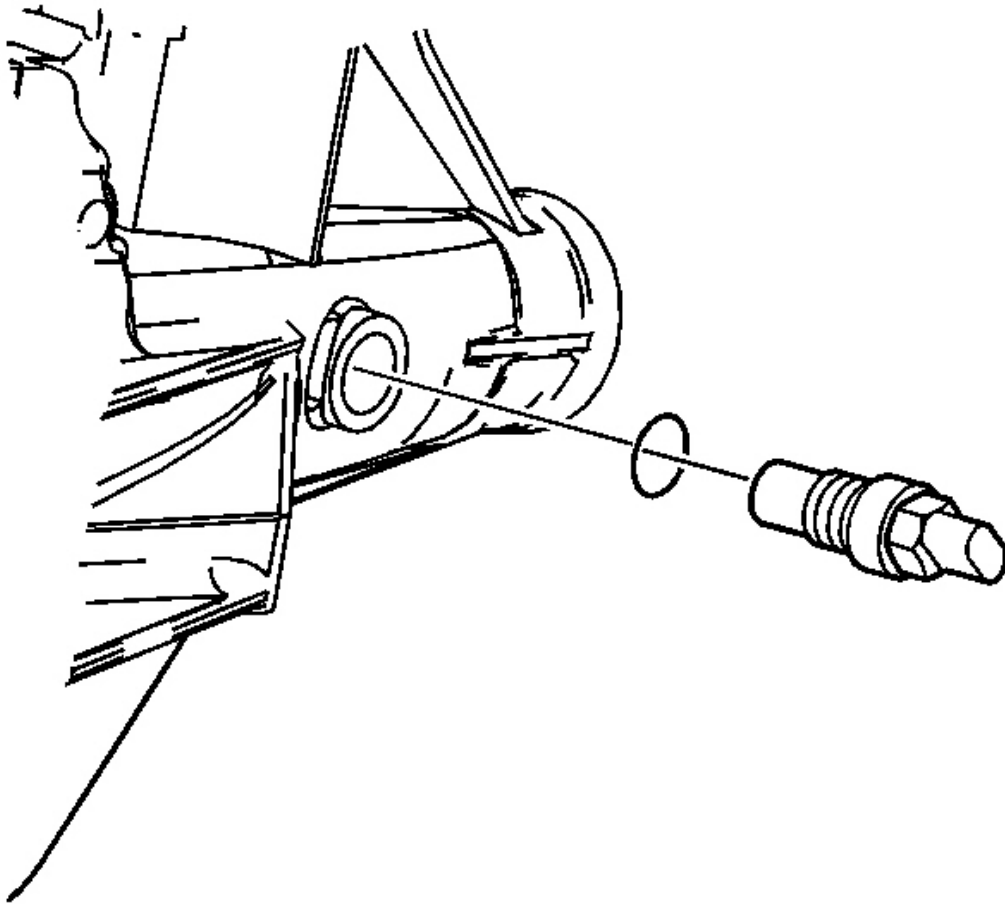

Fig. 49: View Of Vehicle Speed Sensor (VSS) With O-Ring Seal
Courtesy of GENERAL MOTORS CORP.

2. If RWD, remove the vehicle speed sensor with O-ring seal.

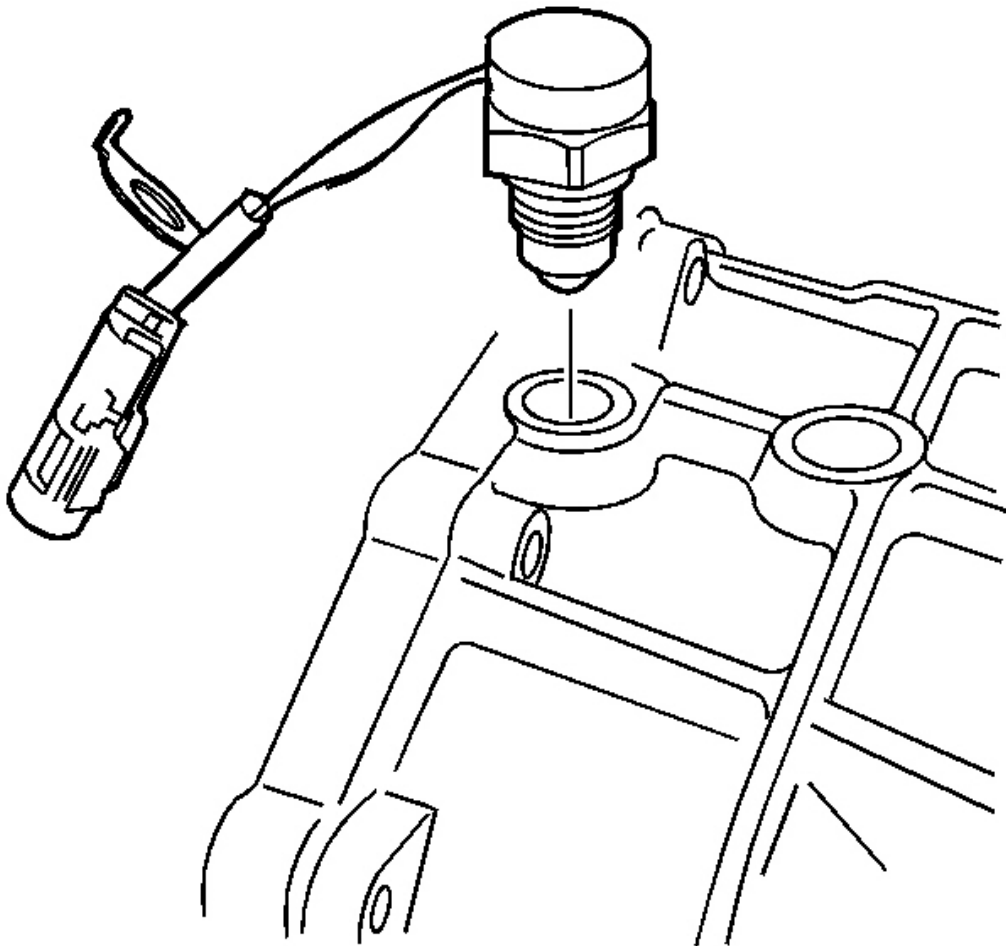

Fig. 50: View Of Backup Lamp Switch
Courtesy of GENERAL MOTORS CORP.

3. Remove the backup lamp switch, with the aluminum washer, from the front case.

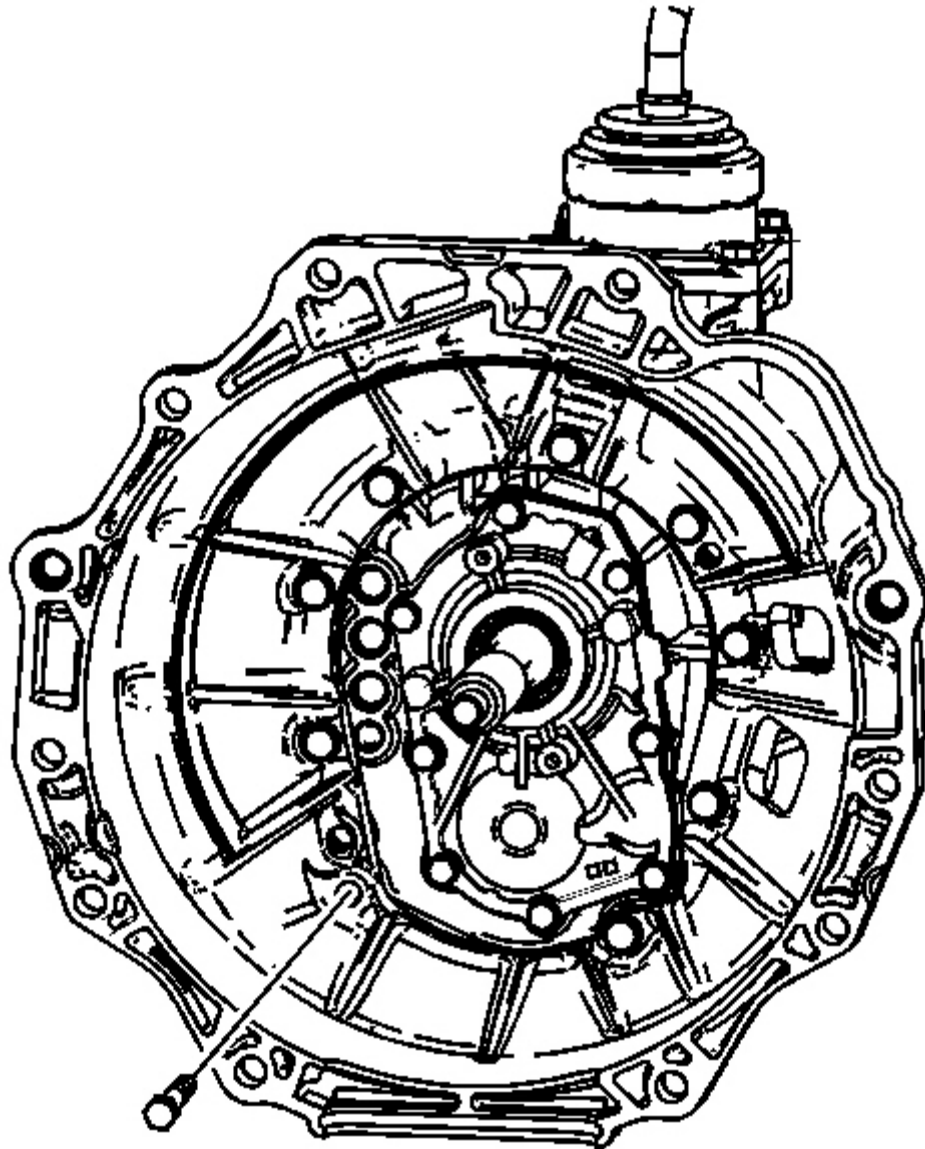

Fig. 51: Identifying Clutch Housing Retaining Bolts
Courtesy of GENERAL MOTORS CORP.

4. Remove the 9 bolts retaining the clutch housing.
5. Using a soft-face hammer, remove the clutch housing from the transmission assembly.

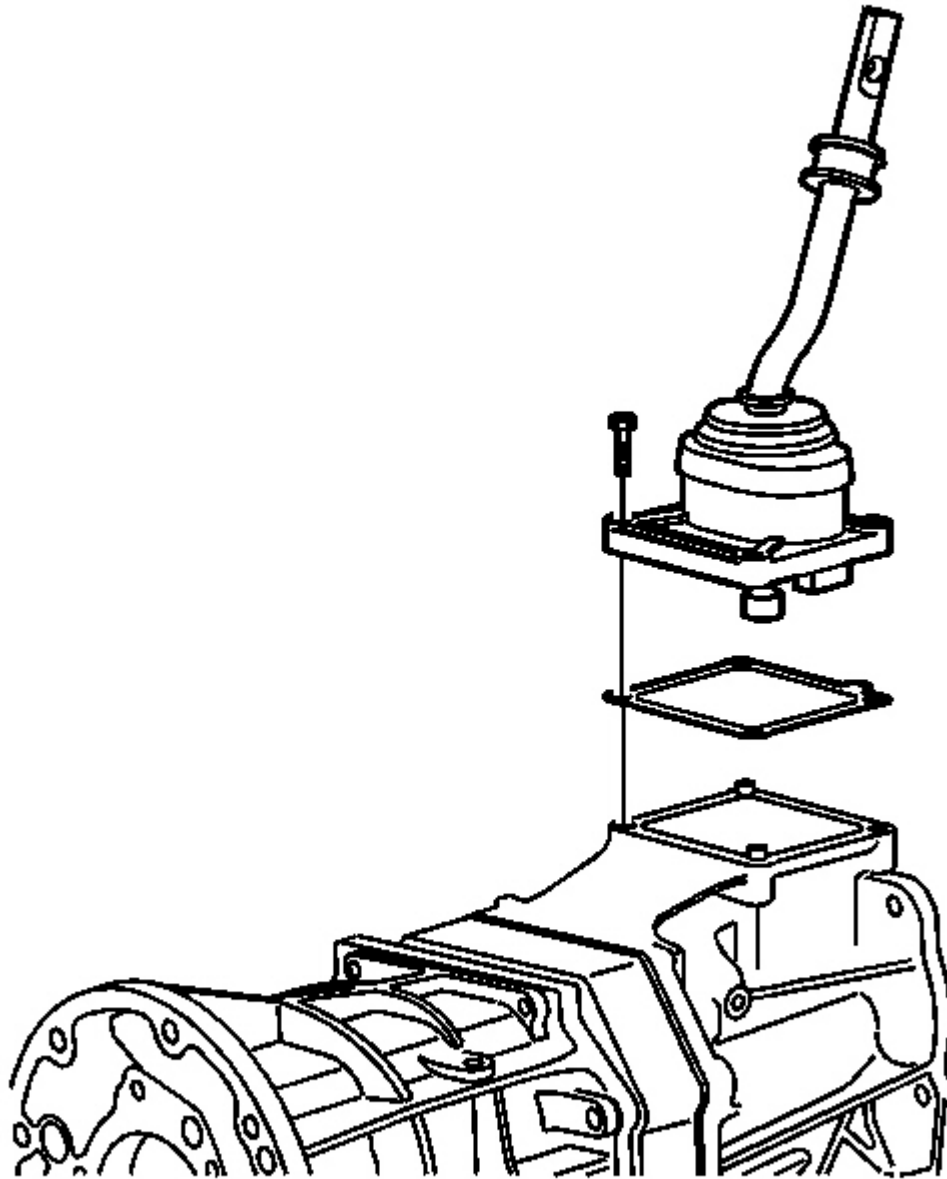

Fig. 52: Locating Shift Control Housing & Gasket
Courtesy of GENERAL MOTORS CORP.

6. Shift the transmission into NEUTRAL.
7. Remove the shift control housing bolts.

8. Remove the shift control housing.
9. Remove the shift control housing gasket.

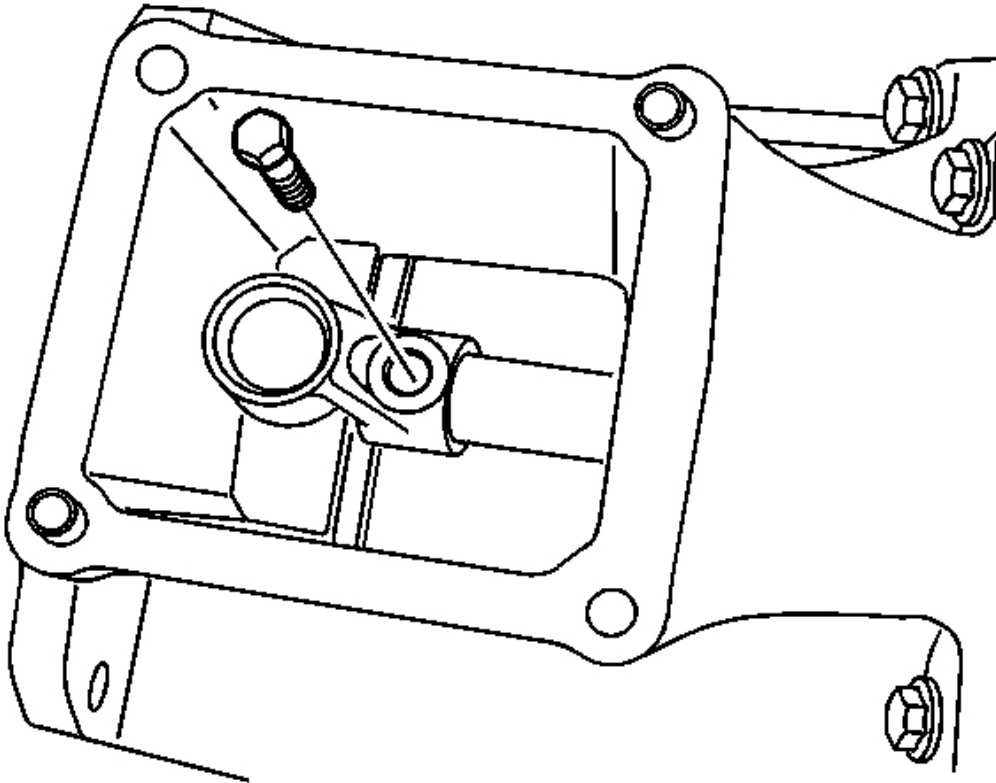

Fig. 53: View Of Shift Control Lever Socket Bolt
Courtesy of GENERAL MOTORS CORP.

10. Remove the shift control lever socket bolt.

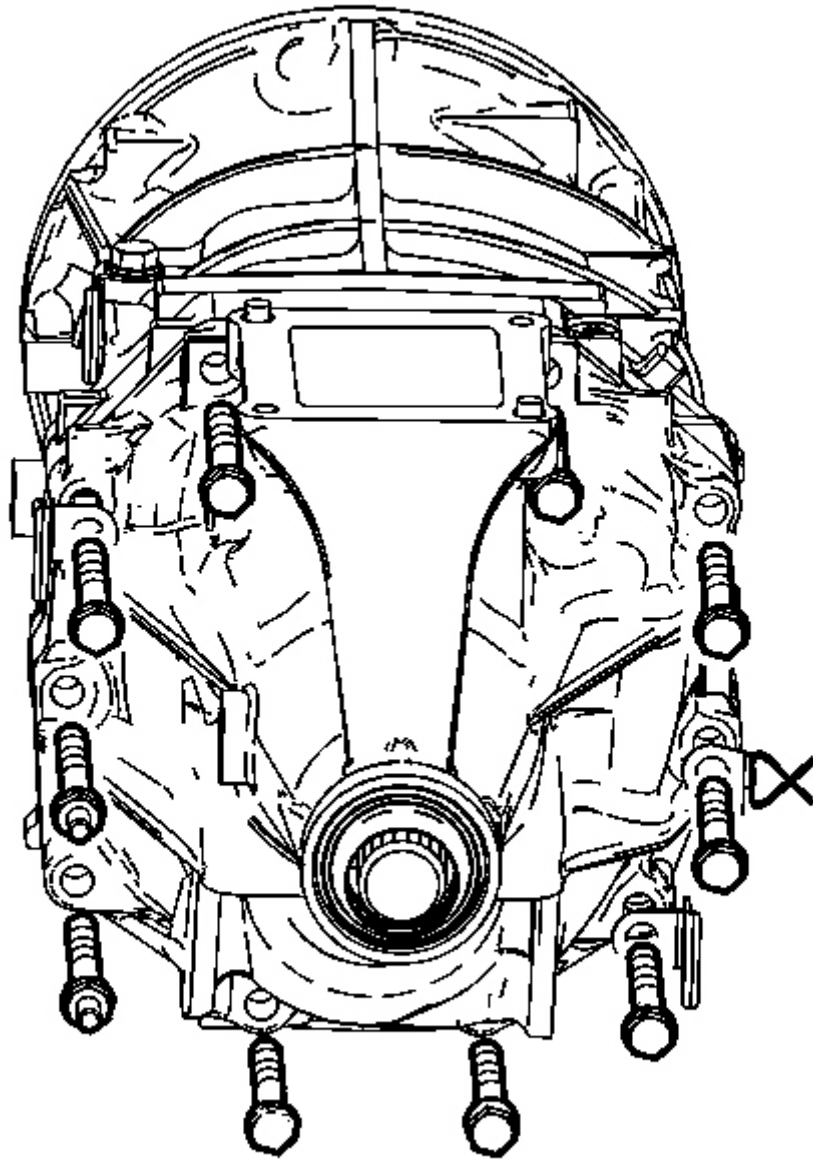

Fig. 54: Identifying Extension Housing Retaining Bolts And Studs
Courtesy of GENERAL MOTORS CORP.

11. Mark the location of the brackets and the studs.
12. Remove the extension housing retaining bolts, studs and brackets.

The 4WD does not use a bracket on the left side of the transmission.

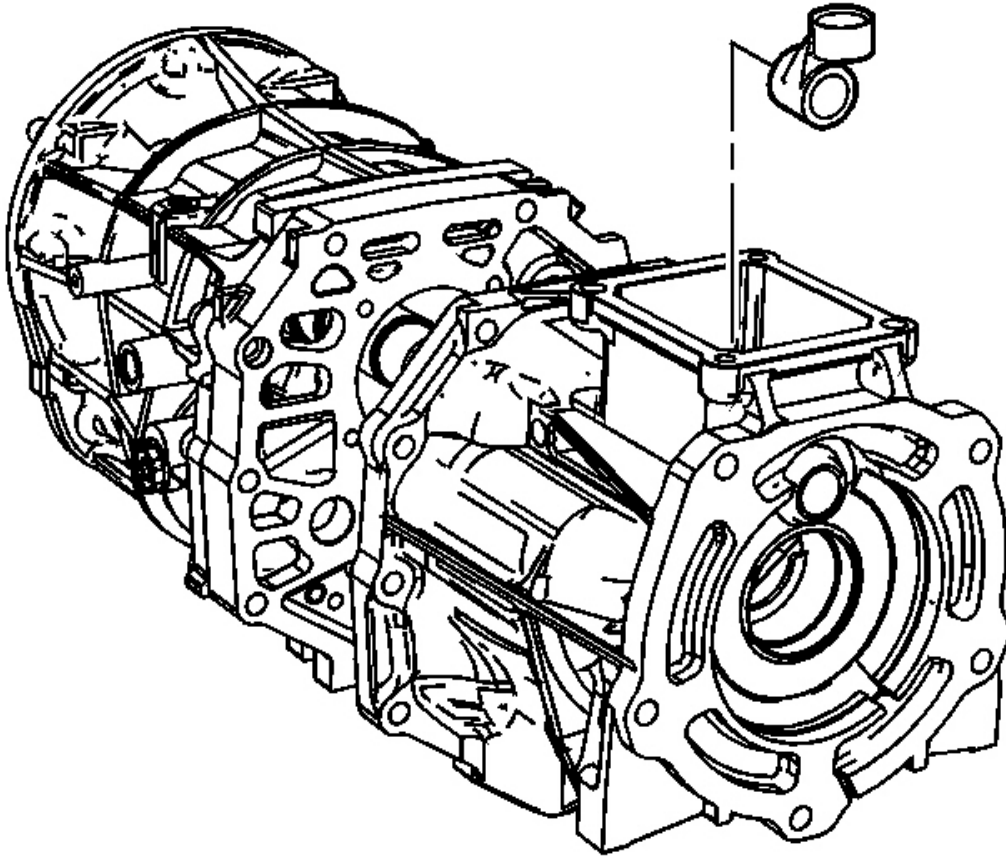

Fig. 55: Locating Shift Control Socket At Extension Housing Shift Lever Cavity
Courtesy of GENERAL MOTORS CORP.

NOTE: Refer to Machined Surface Damage Notice .

13. Using a soft-face hammer, separate the extension housing from the intermediate case.
14. Slide the extension housing off the shift control shaft.
15. Remove the shift control socket from the extension housing shift lever cavity.

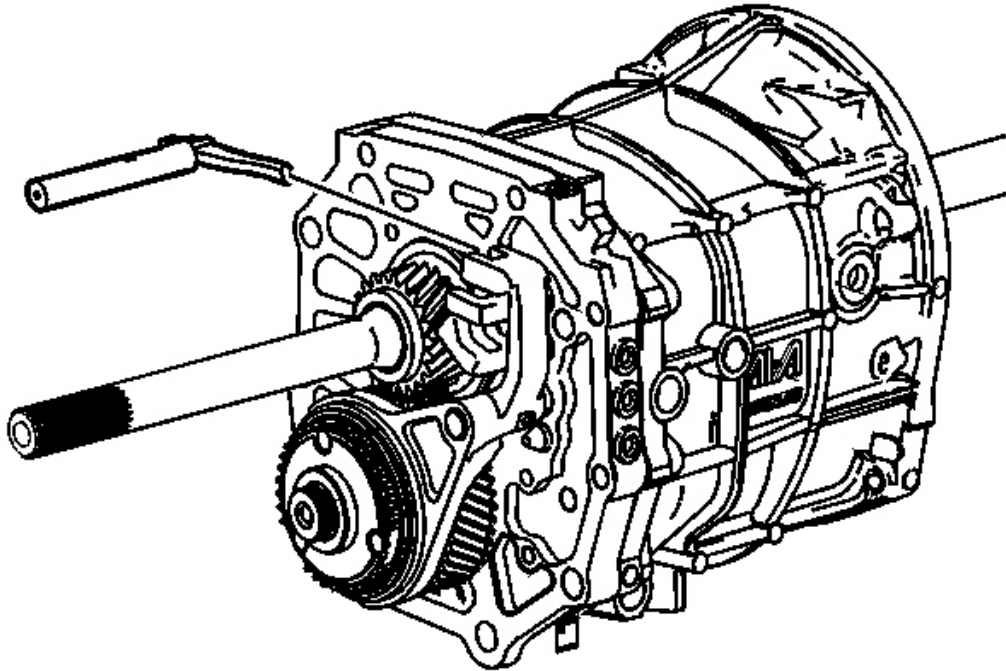

Fig. 56: Identifying Shift Control Shaft
Courtesy of GENERAL MOTORS CORP.

16. Remove the shift control shaft from the shift shaft gates.

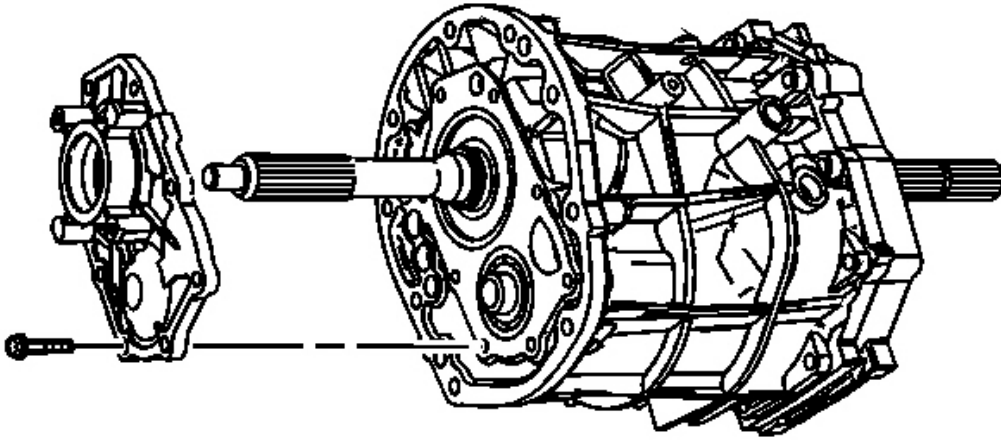

Fig. 57: Locating Input Shaft Bearing Retainer Bolts
Courtesy of GENERAL MOTORS CORP.

17. Remove the front bearing retainer bolts. Discard the bolts. New bolts are required for assembly.
18. Remove the front bearing retainer.

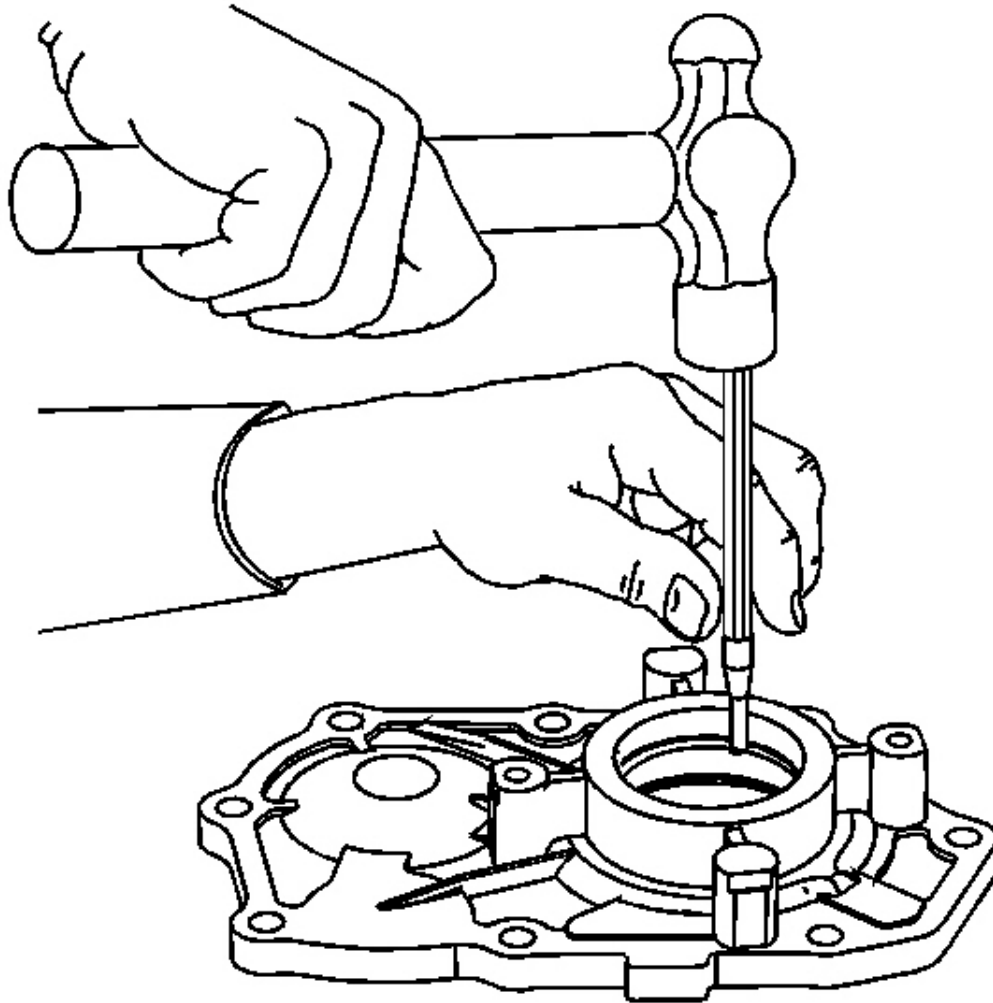

Fig. 58: Removing/Installing Input Shaft Seal
Courtesy of GENERAL MOTORS CORP.

19. Using a suitable punch and a hammer, remove the input shaft seal from the bearing retainer. Do not use the seal again.

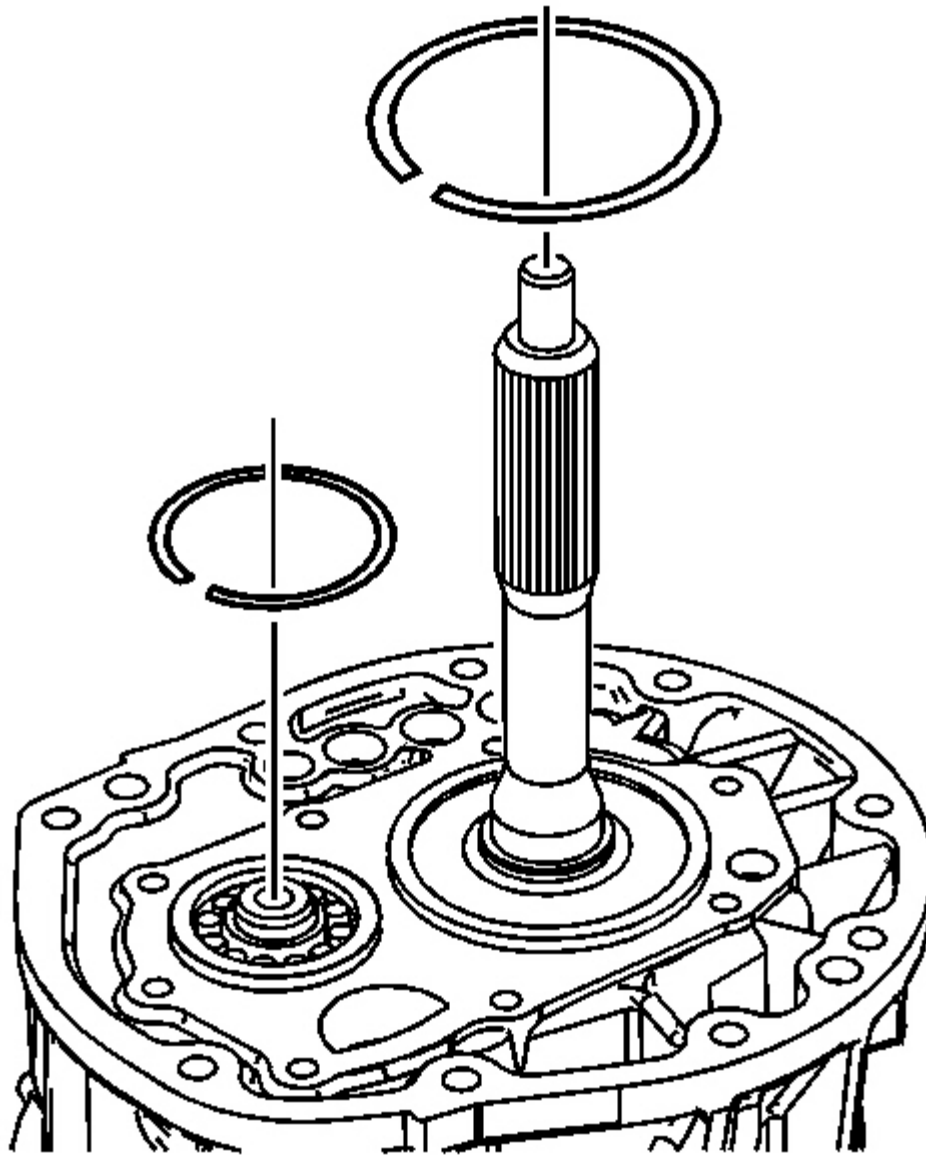

Fig. 59: Locating Outer Retaining Rings On Input Shaft Bearing & Countershaft Front Bearing
Courtesy of GENERAL MOTORS CORP.

20. Remove the outer retaining ring from the input shaft bearing.

21. Remove the outer retaining ring from the countershaft front bearing.

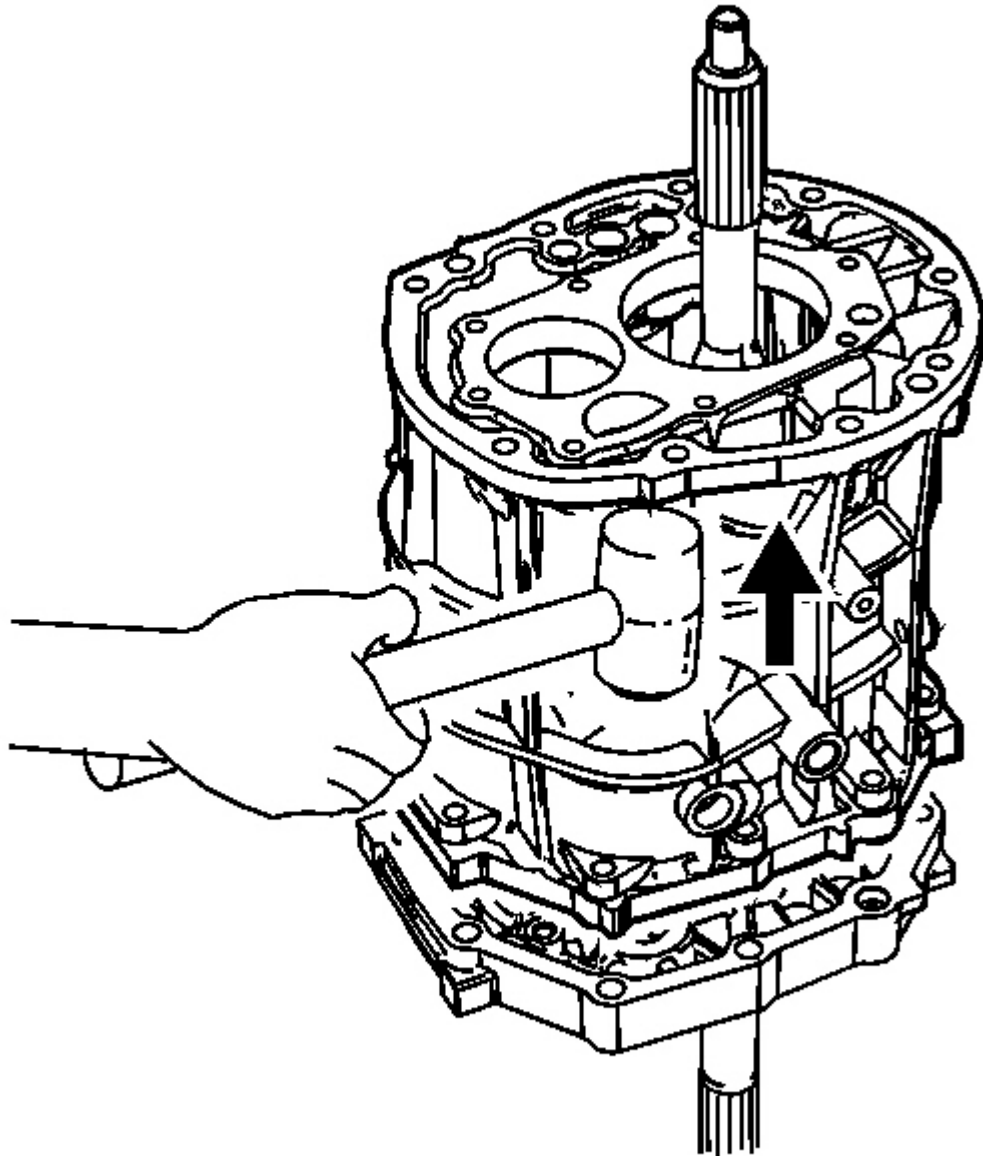

Fig. 60: Shearing Sealer On Transmission Front Case
Courtesy of GENERAL MOTORS CORP.

NOTE: Refer to Machined Surface Damage Notice .

22. Using a soft-face hammer on the transmission front case, shear the sealer.
23. Remove the transmission front case from the intermediate case.

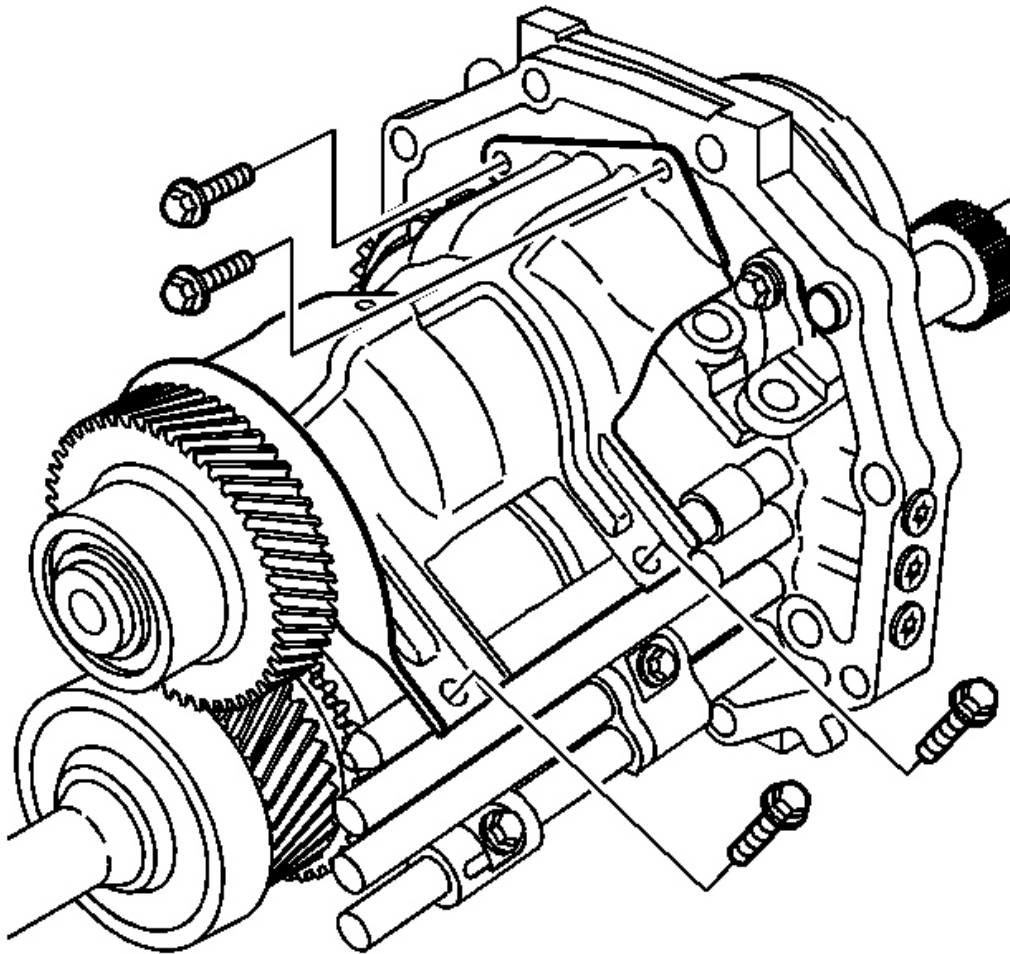

Fig. 61: Locating Oil Baffle Bolts
Courtesy of GENERAL MOTORS CORP.

24. Remove the oil baffle bolts.
25. Remove the oil baffle.

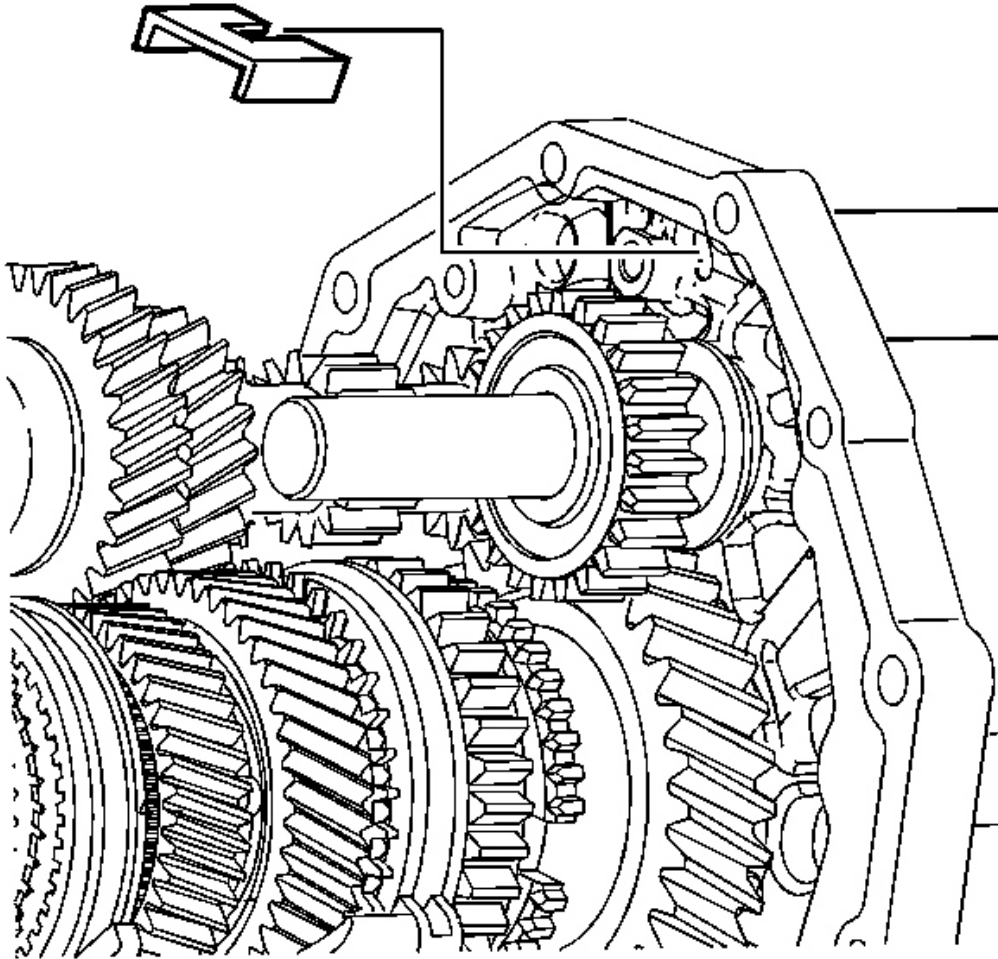

Fig. 62: View Of Transmission Magnet
Courtesy of GENERAL MOTORS CORP.

26. Remove the magnet.

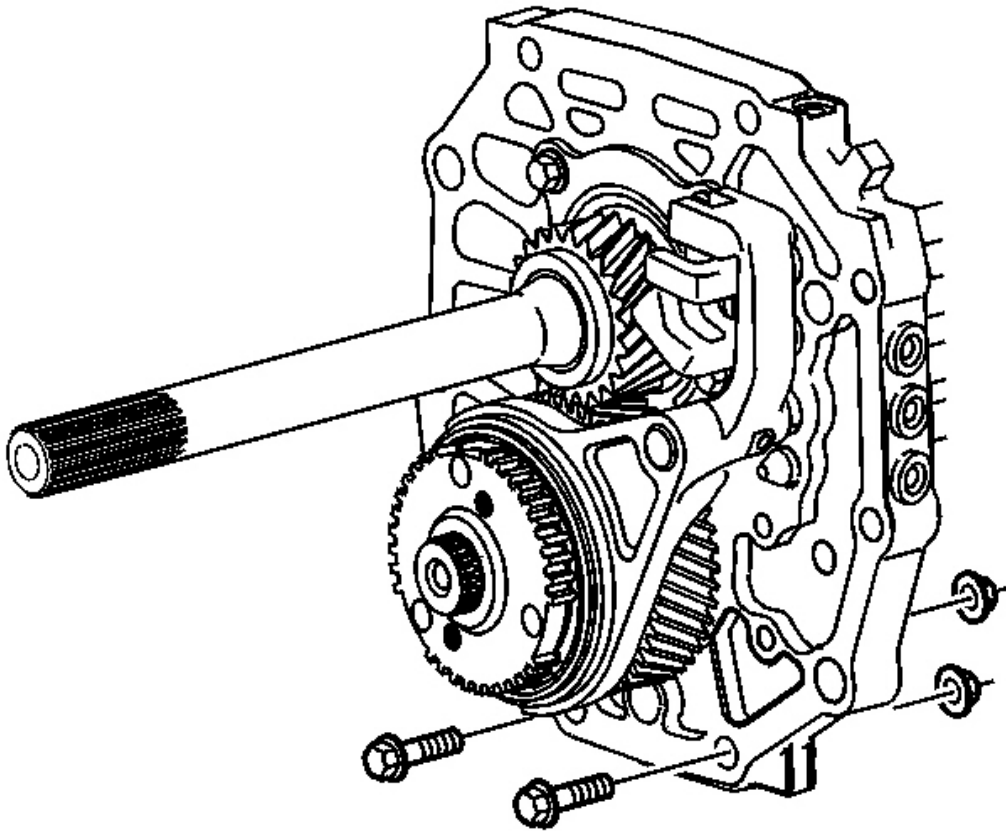

Fig. 63: Installing Intermediate Case Temporary Mounting Bolts
Courtesy of GENERAL MOTORS CORP.

NOTE: Refer to Machined Surface Damage Notice .

27. Install 2 bolts, with nuts, in the lower holes of the intermediate case. The bolts will be used to hold the intermediate case in a vise during disassembly and assembly.

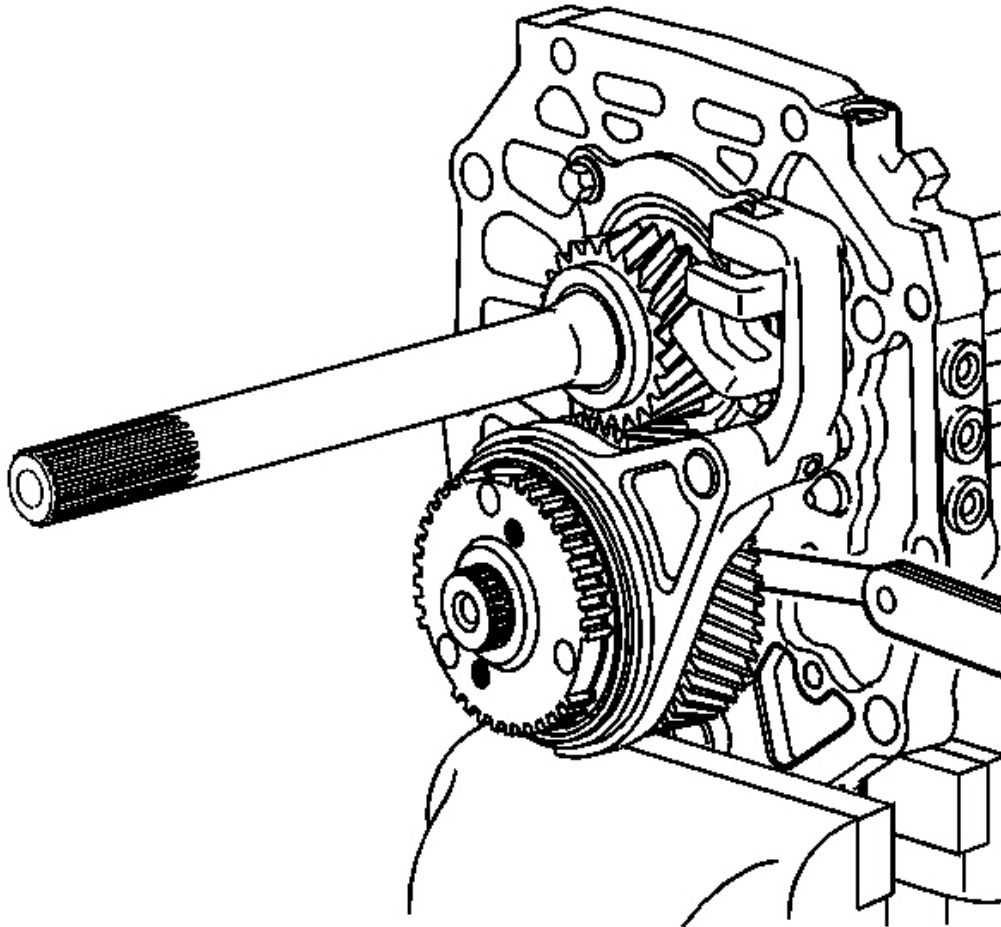

Fig. 64: Measuring Axial Clearance On 5th Gear & Thrust Washer
Courtesy of GENERAL MOTORS CORP.

IMPORTANT: Before removal of the 5th synchronizer gear, measure the axial play of the speed gear. Incorrect axial play of the gear may cause shifting concerns or transmission noise.

28. Using a feeler gage between the 5th countershaft gear and the thrust washer, measure the axial clearance.

Specification:

- Standard Clearance: 0.10-0.35 mm (0.0039-0.0138 in)

- Maximum Clearance: 0.40 mm (0.0157 in)

29. If the clearance exceeds the maximum, refer to **Gears and Shafts Cleaning and Inspection**.

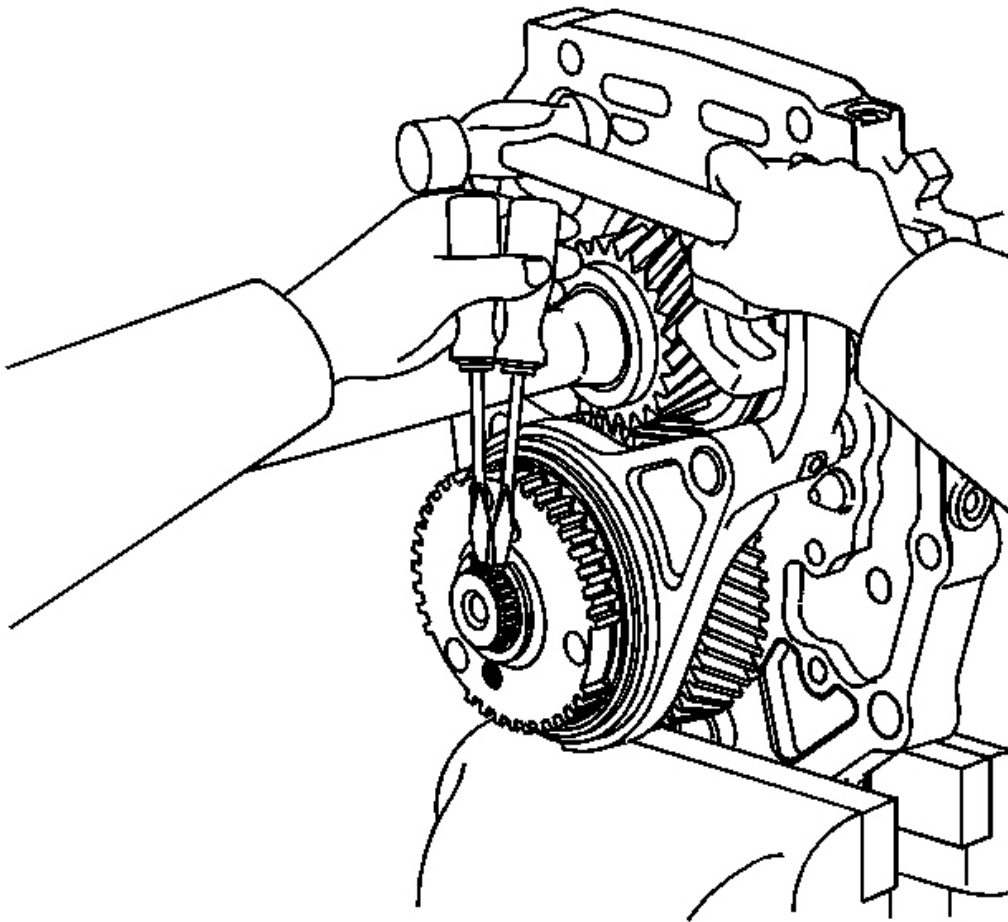

Fig. 65: Removing/Installing 5th Synchronizer Gear Retaining Ring
Courtesy of GENERAL MOTORS CORP.

30. Mount the intermediate case assembly in a vise on the 2 previously installed bolts.
31. Using 2 screwdrivers and a hammer, remove the 5th synchronizer gear retaining ring.

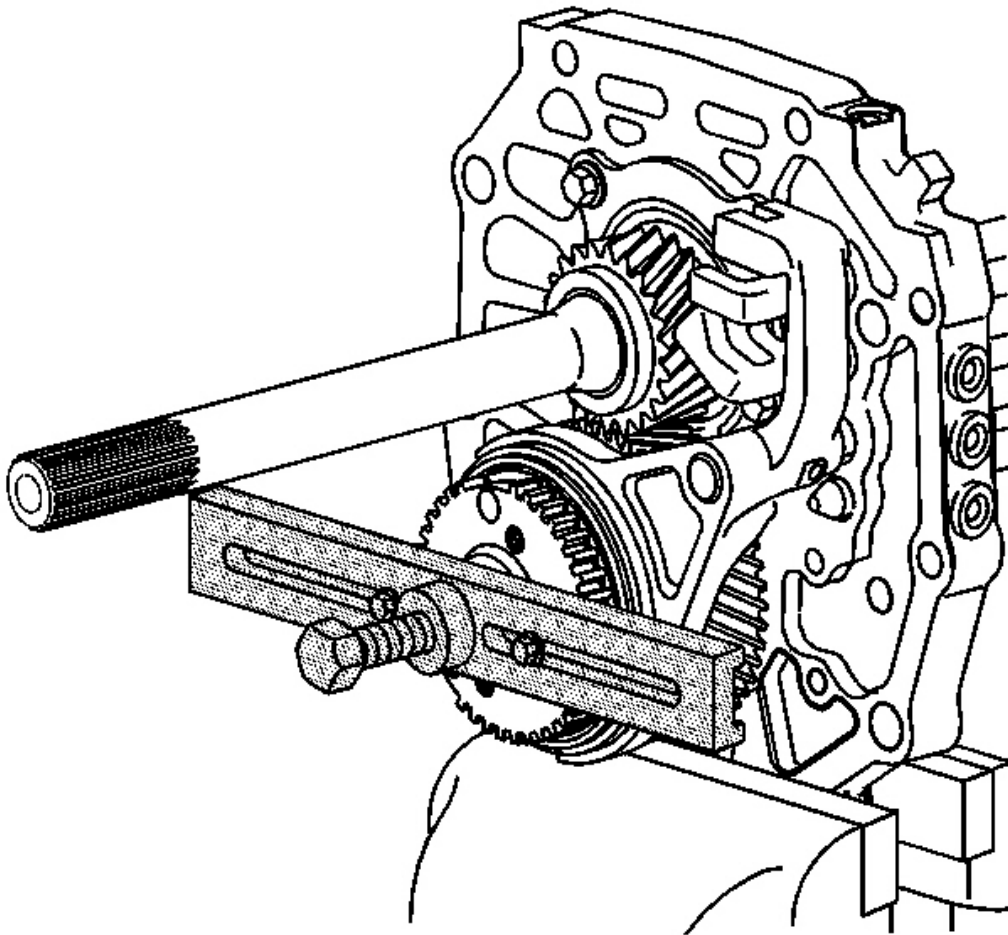

Fig. 66: Removing 5th Synchronizer Gear Using J 8433
Courtesy of GENERAL MOTORS CORP.

32. Using **J 8433** with 2 bolts in the threaded holes of the 5th synchronizer gear, remove the gear.

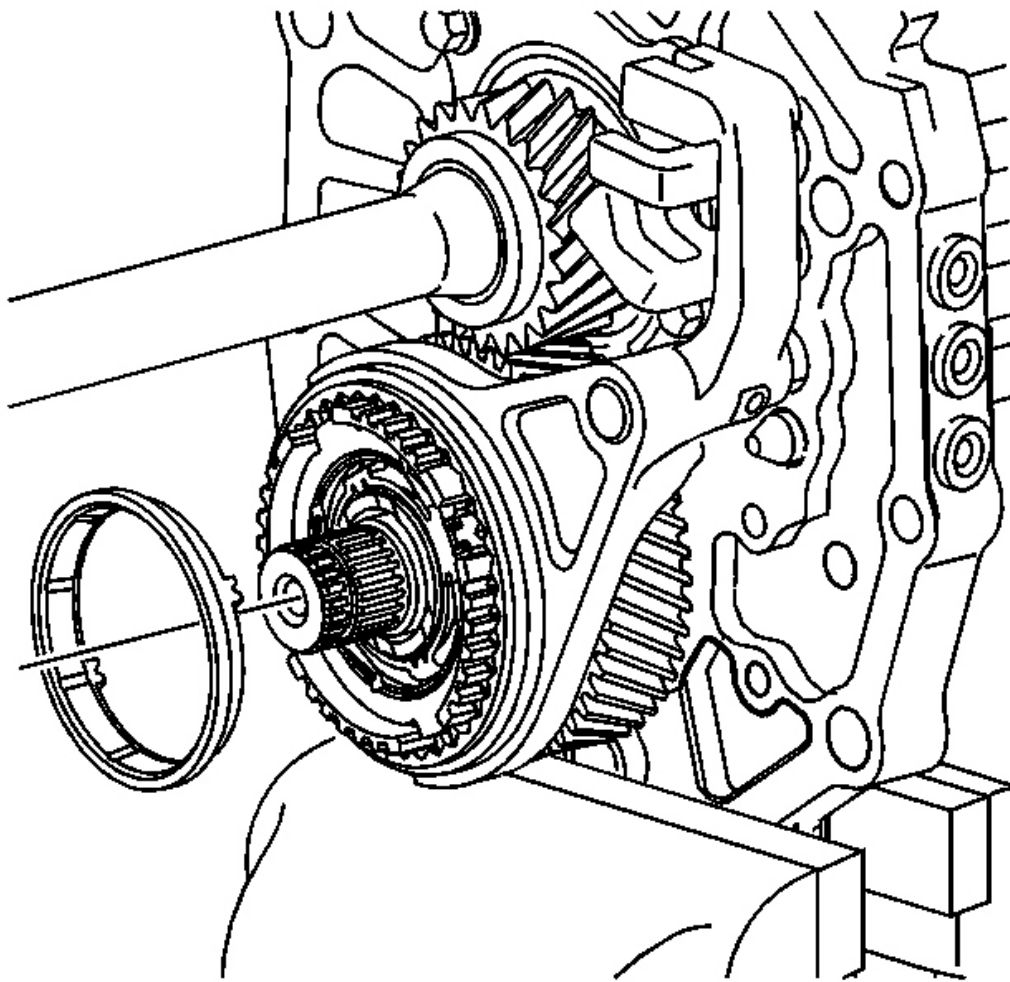

Fig. 67: View Of 5th/Reverse Gear Synchronizer
Courtesy of GENERAL MOTORS CORP.

33. Remove the 5th/reverse gear synchronizer.

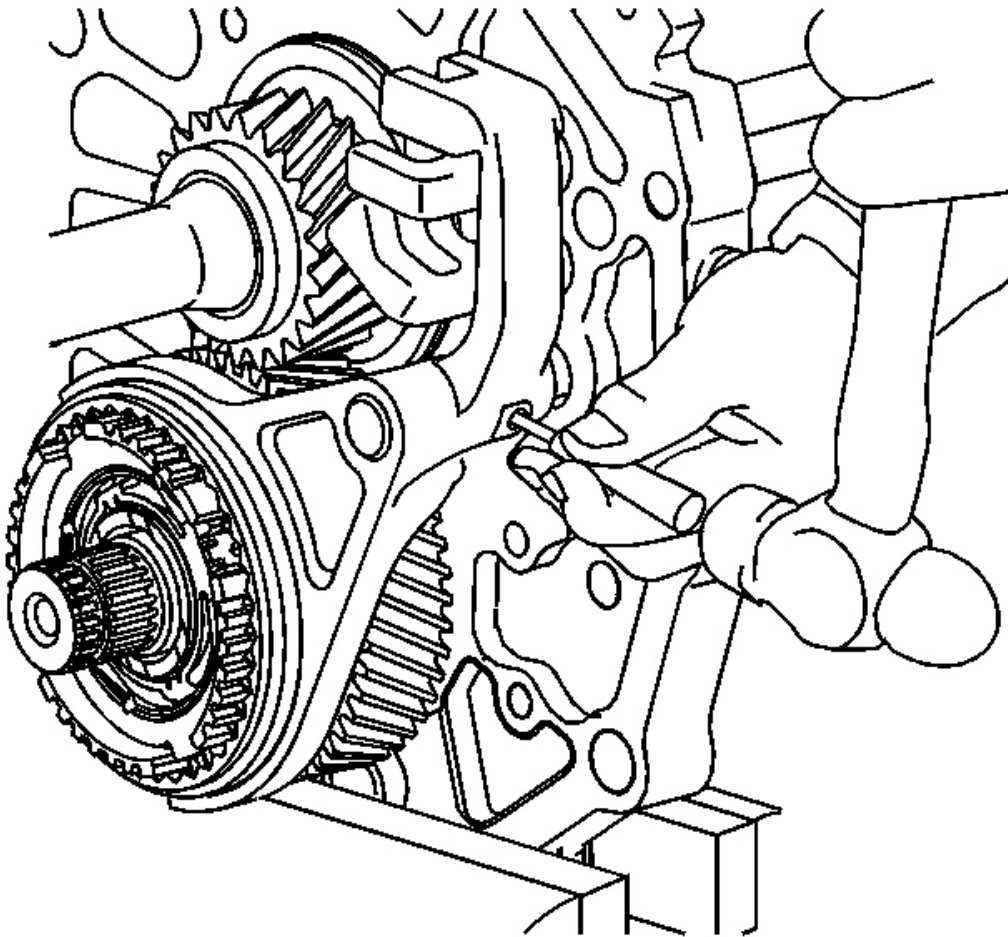

Fig. 68: Removing/Installing 5th Shift Fork Roll Pin
Courtesy of GENERAL MOTORS CORP.

34. Using a hammer and a punch, remove the 5th shift fork roll pin.

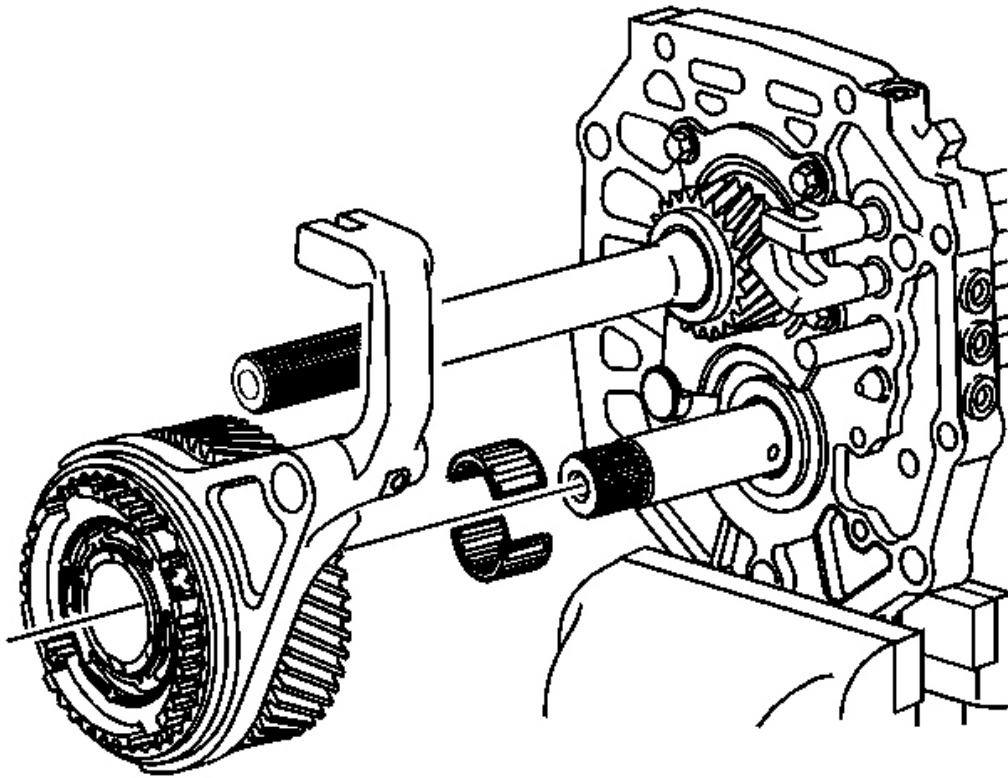

Fig. 69: View Of 5th/Reverse Synchronizer Assembly & 5th Countershaft Gear Bearing

Courtesy of GENERAL MOTORS CORP.

35. Remove the shift fork, the 5th/reverse synchronizer sleeve and blocking ring assembly and the 5th countershaft gear and bearing.

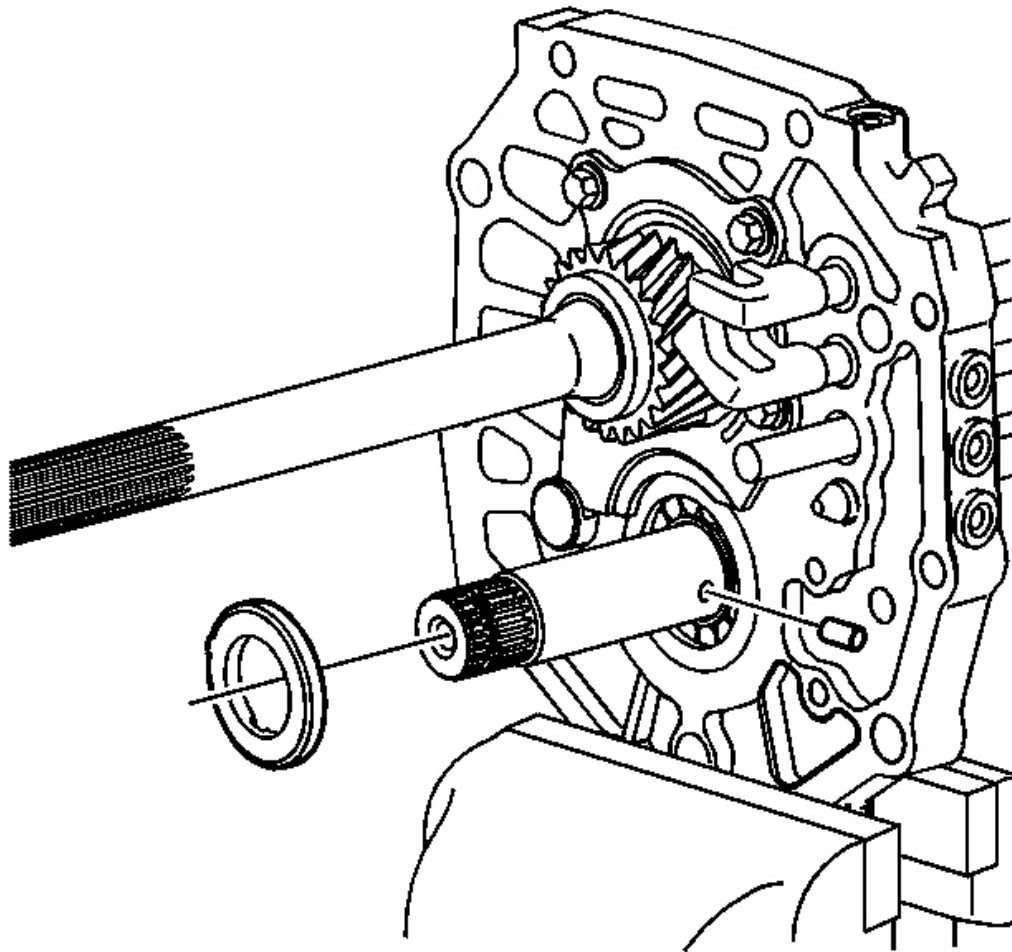

Fig. 70: Locating 5th Gear Thrust Washer
Courtesy of GENERAL MOTORS CORP.

36. Remove the 5th countershaft gear thrust washer.
37. Remove the thrust washer lock pin.

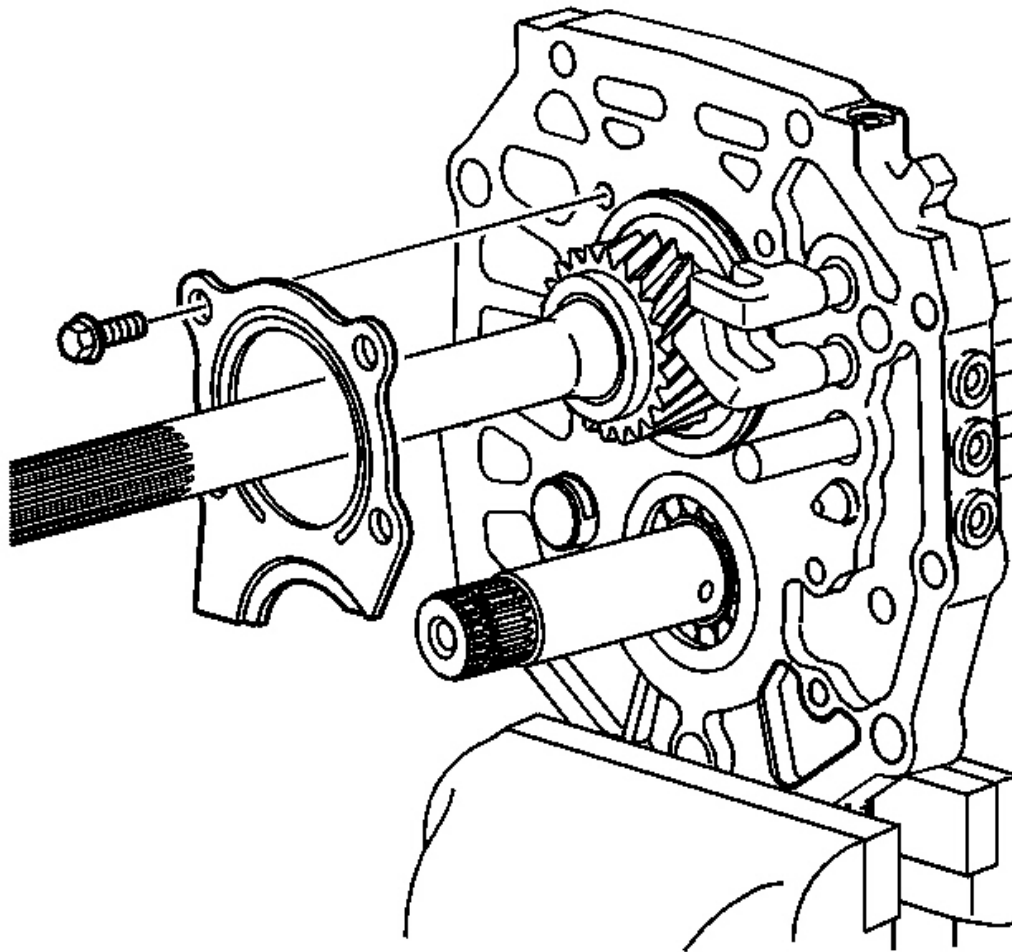

Fig. 71: Identifying Rear Bearing Retainer & Retaining Bolts
Courtesy of GENERAL MOTORS CORP.

38. Remove the bolts for the rear bearing retainer.
39. Remove the rear bearing retainer.

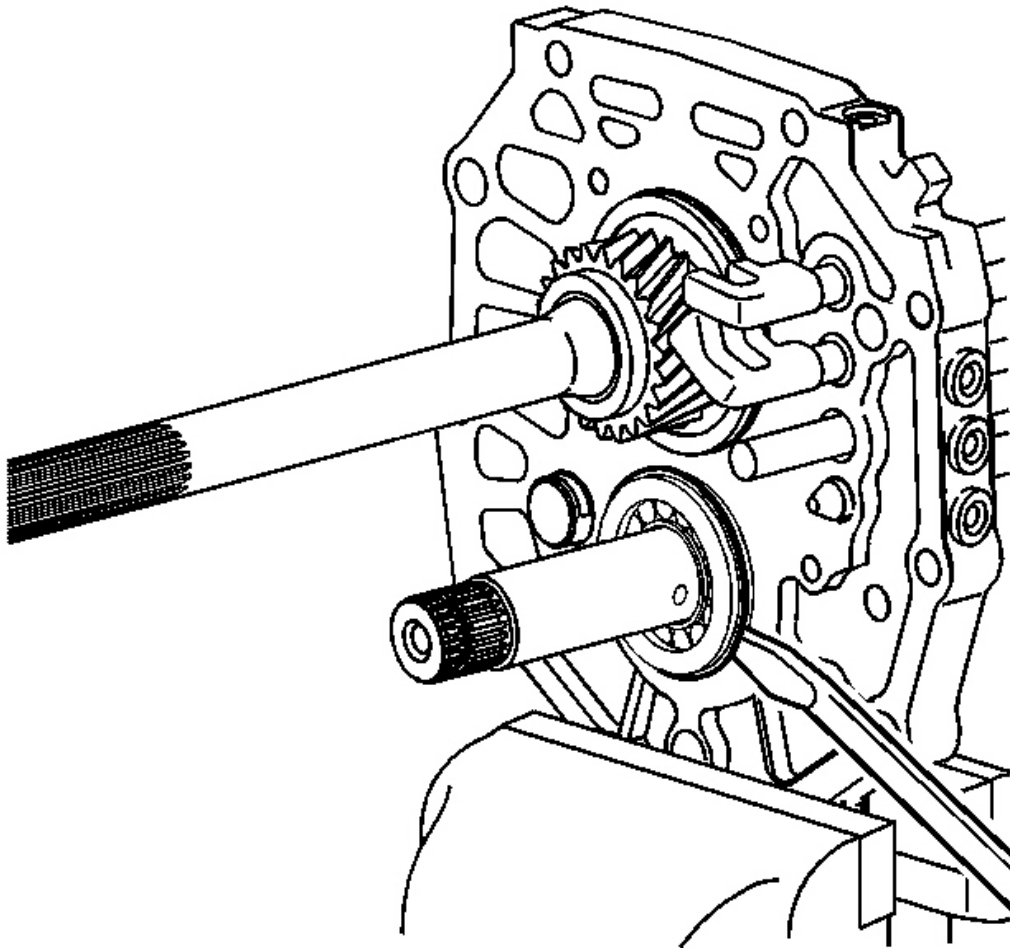

Fig. 72: Identifying Outer Retaining Ring On The Countershaft Rear Bearing
Courtesy of GENERAL MOTORS CORP.

40. Using a soft-face hammer, tap the countershaft rearward to expose the outer retaining ring on the countershaft rear bearing.
41. Using a suitable prying tool on the retaining ring, remove the countershaft rear bearing. The bearing will slide out of the case if the countershaft is kept in position with the output shaft.

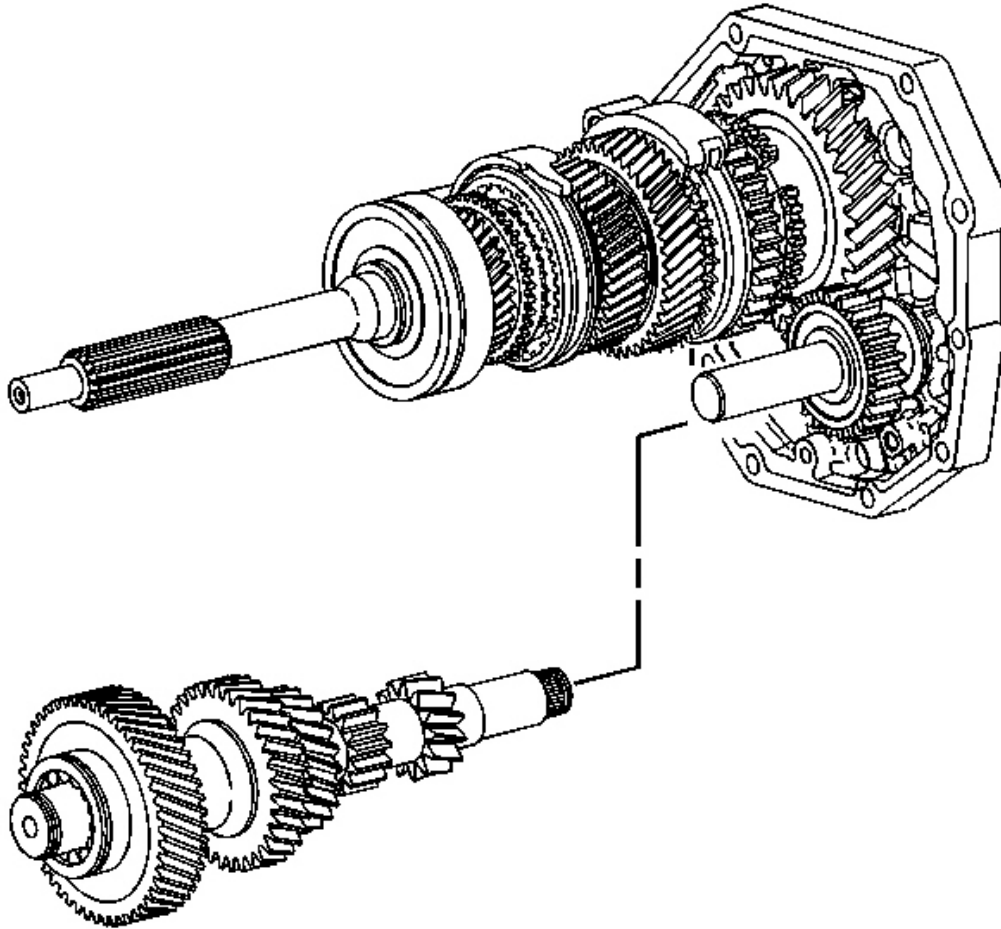

Fig. 73: View Of Countershaft
Courtesy of GENERAL MOTORS CORP.

42. Remove the countershaft.

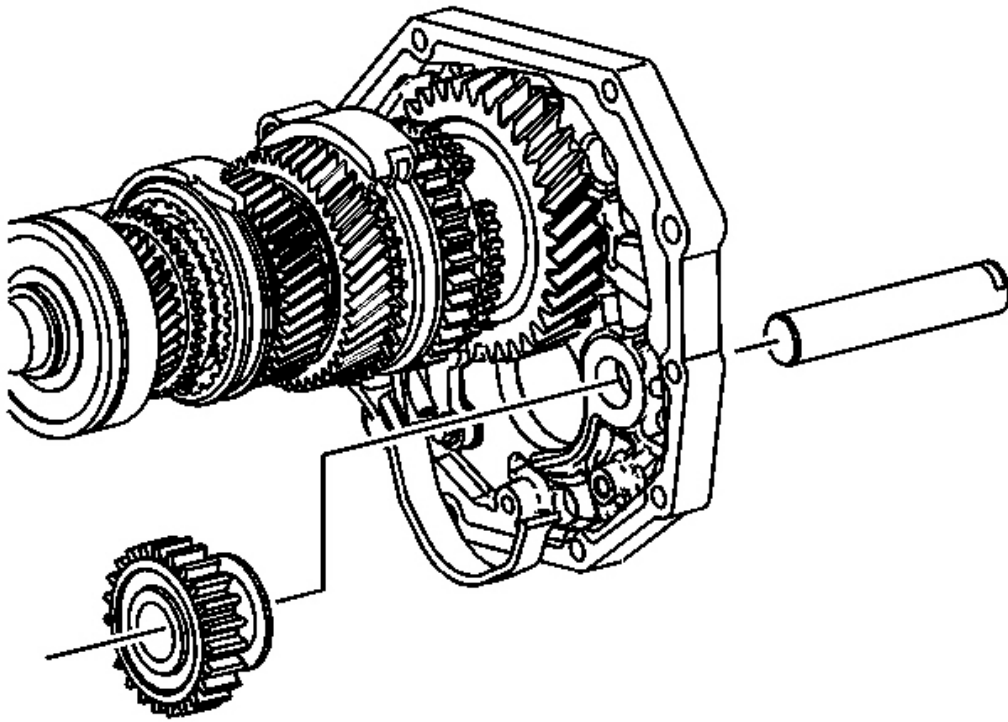

Fig. 74: Locating Reverse Gear Idler Shaft & Reverse Idler Gear
Courtesy of GENERAL MOTORS CORP.

43. Remove the reverse idler gear shaft and reverse idler gear.

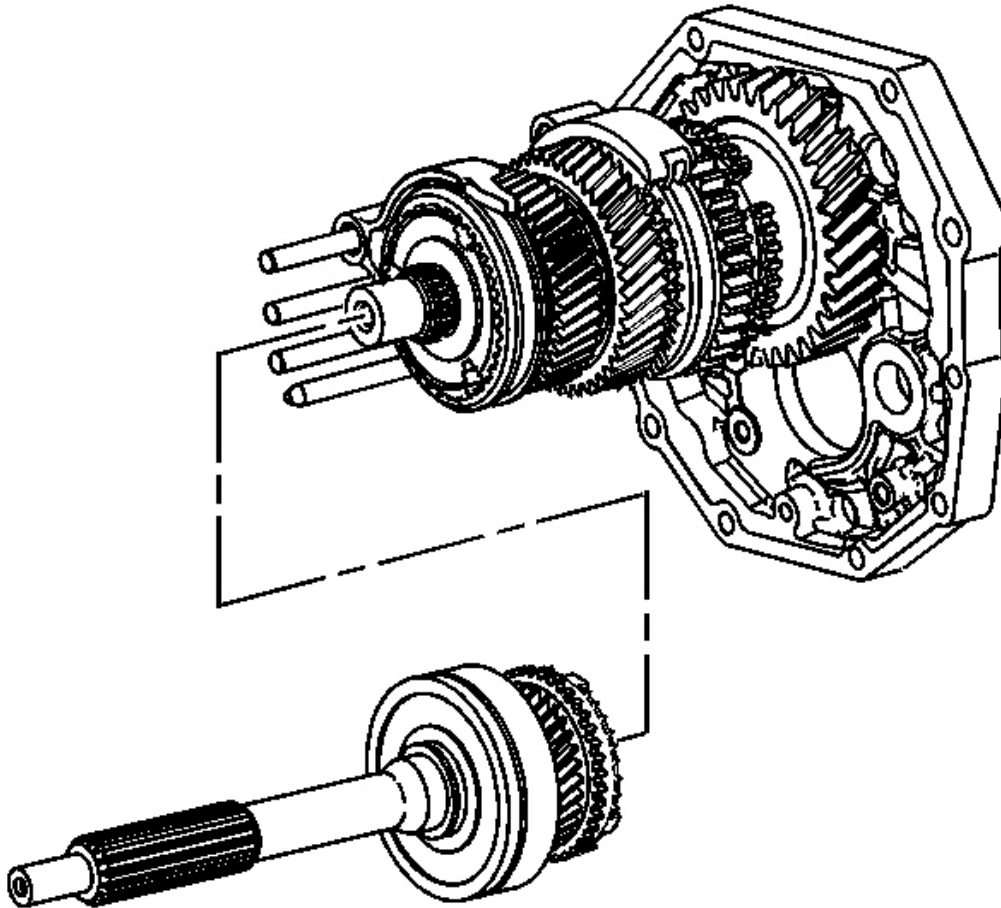

Fig. 75: View Of Input Shaft Assembly
Courtesy of GENERAL MOTORS CORP.

44. Remove the input shaft assembly, with the 4th gear blocking ring and output shaft front support bearing from the output shaft.

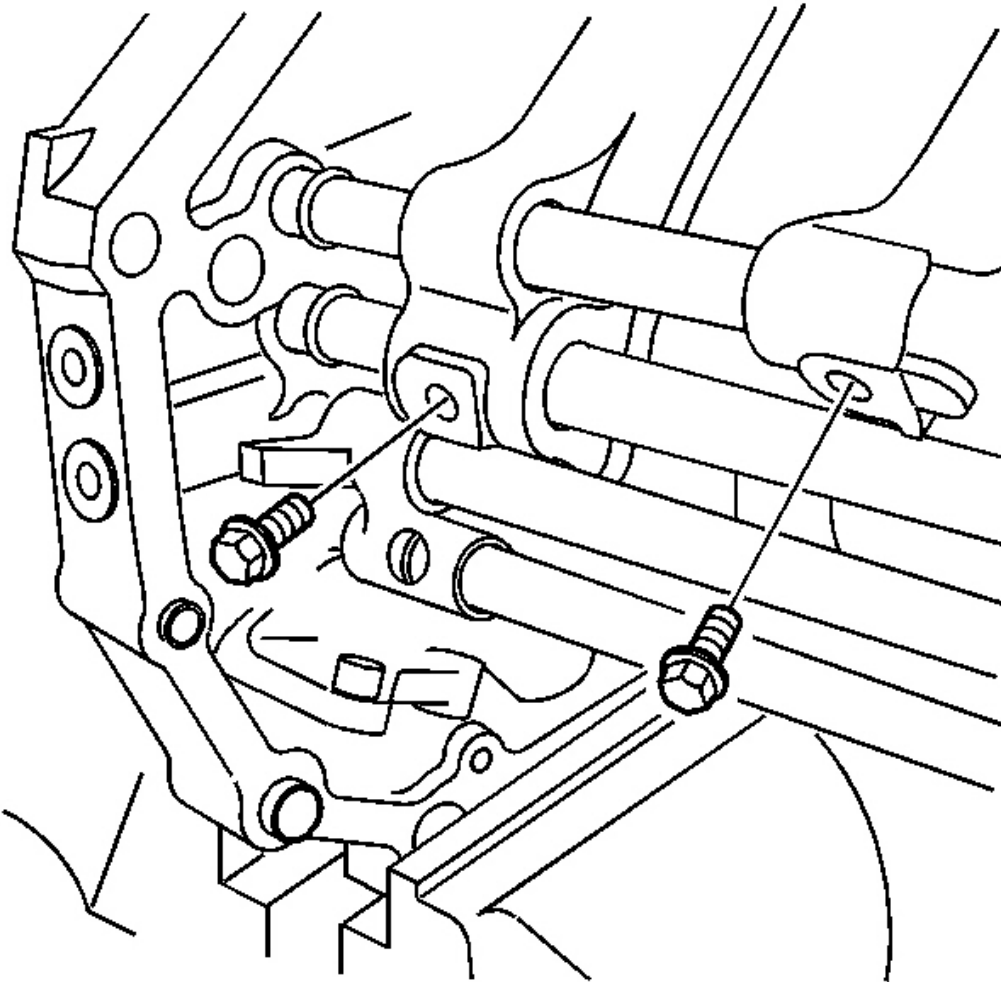

Fig. 76: Identifying Shift Fork Bolts
Courtesy of GENERAL MOTORS CORP.

45. Remove the 1st/2nd shift fork bolt.
46. Remove the 3rd/4th shift fork bolt.

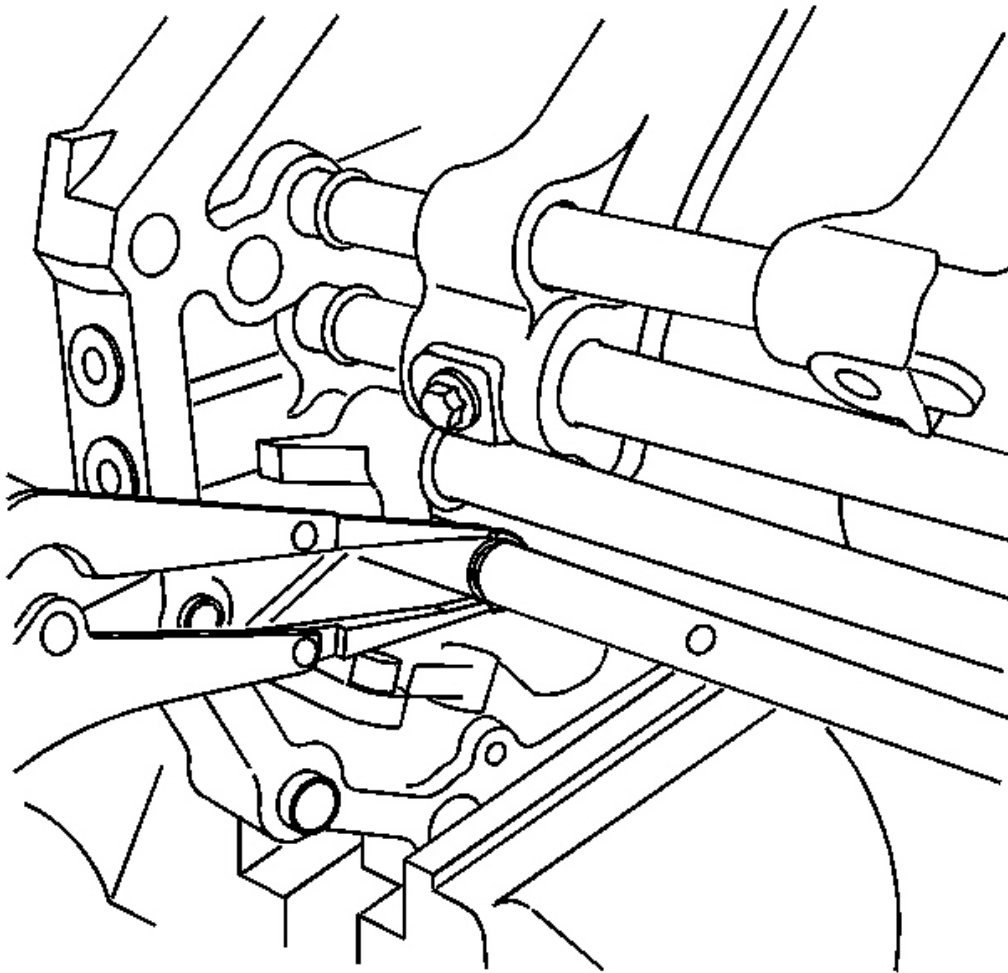

Fig. 77: Locating Retaining Ring For The Reverse Shift Lever
Courtesy of GENERAL MOTORS CORP.

47. Remove the retaining ring for the reverse shift lever on the reverse shift shaft.
 - Use a suitable pair of pliers to push the retaining ring.
 - Only push the retaining ring partially off to keep it from flying.
 - Use a pair of pliers to remove the retaining ring the rest of the way.

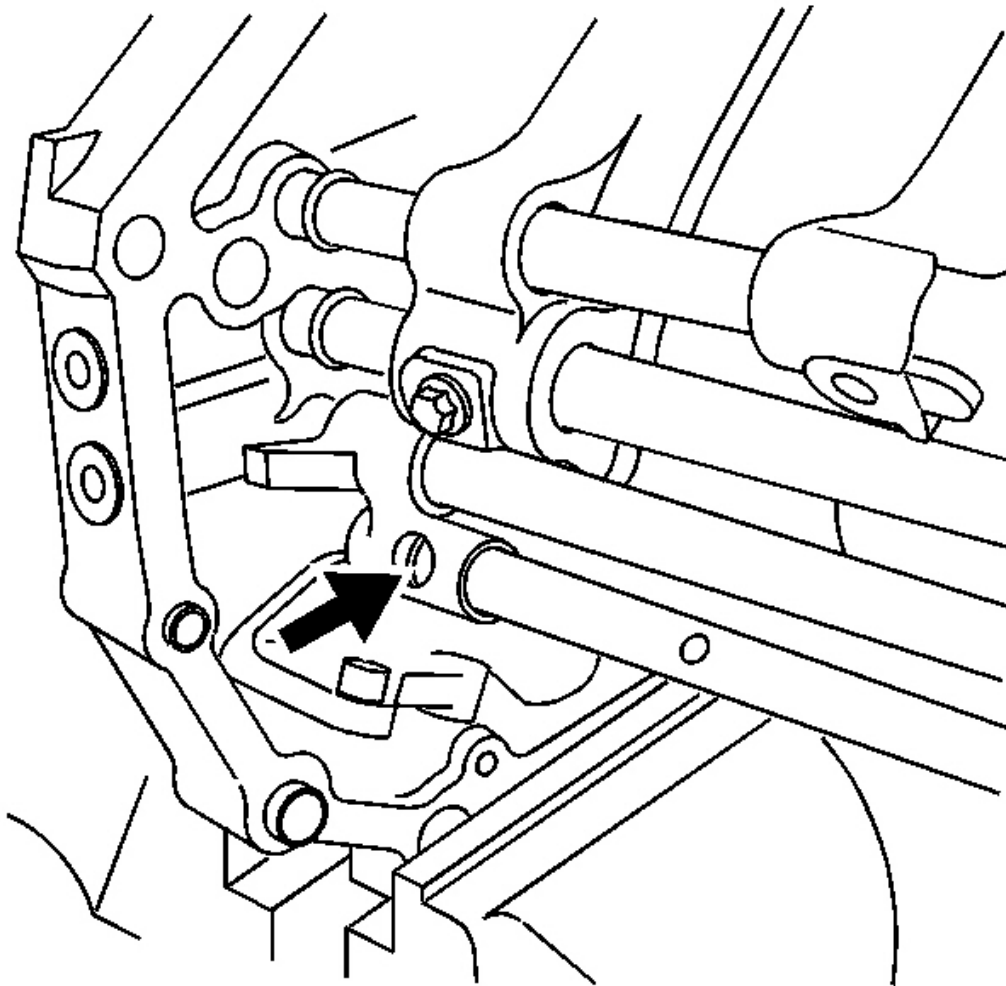

Fig. 78: View Of Retaining Ring Groove On Reverse Shift Shaft
Courtesy of GENERAL MOTORS CORP.

48. Shift the reverse shift shaft forward.
49. Move the reverse shift lever forward past the retaining ring groove on the reverse shift shaft. This allows clearance of the reverse shift fork during removal of the output shaft.

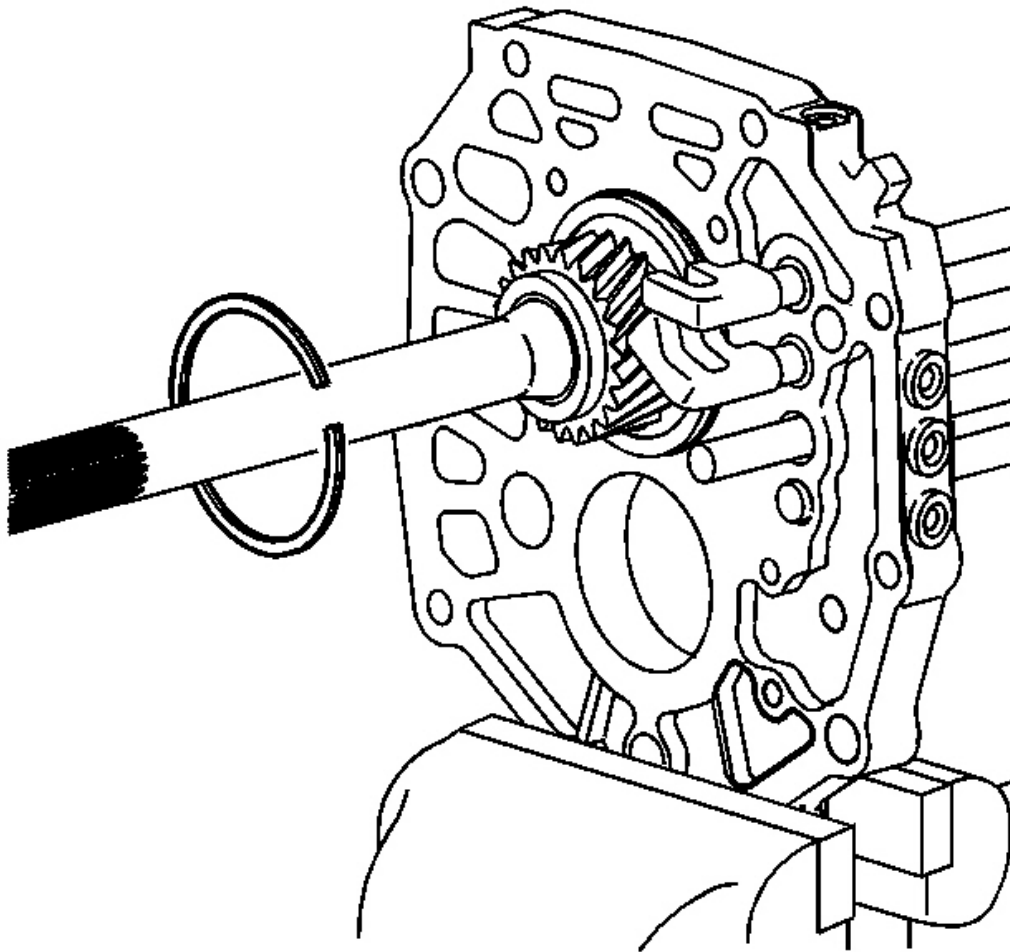

Fig. 79: View Of Output Shaft Rear Bearing Outer Retaining Ring
Courtesy of GENERAL MOTORS CORP.

50. Remove the output shaft rear bearing outer retaining ring.

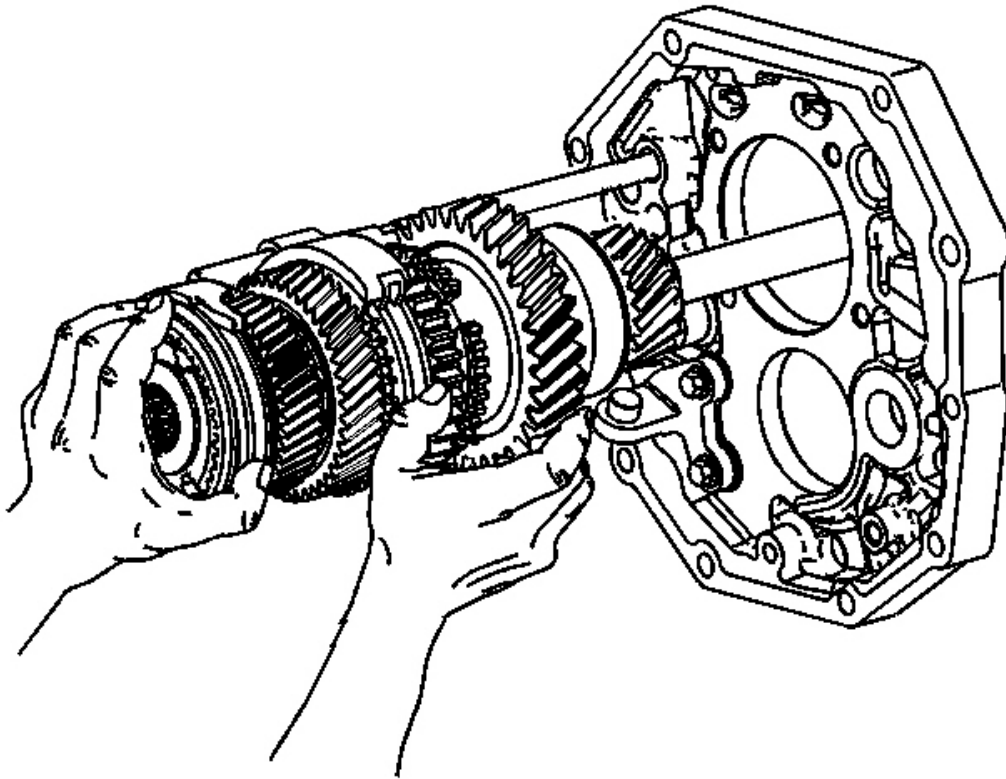

Fig. 80: Identifying Output Shaft Assembly
Courtesy of GENERAL MOTORS CORP.

51. Remove the output shaft assembly.
 - Hold the 1st/2nd shift fork and the 3rd/4th shift fork in position to the output shaft.
 - Slide the 1st/2nd shift fork and the 3rd/4th shift fork off the shift shafts while removing the output shaft.

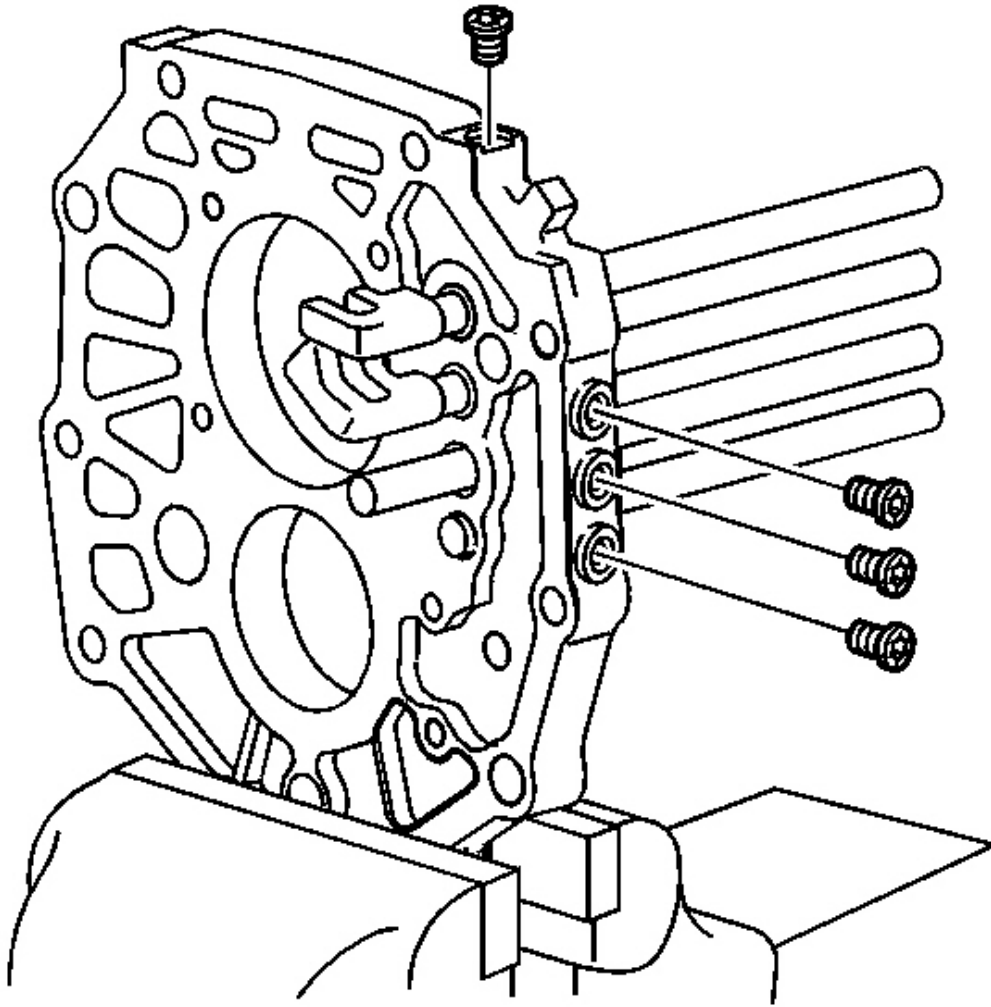

Fig. 81: Locating Shift Shaft Detent Plugs
Courtesy of GENERAL MOTORS CORP.

IMPORTANT: If the shift shafts or the intermediate case do not require service, proceed to Output Shaft Disassemble. If the shift shafts or intermediate case require service, proceed to the next step.

52. Remove the 4 shift shaft detent plugs for the shift detent balls and springs. Discard the plugs.

New plugs are required for assembly.

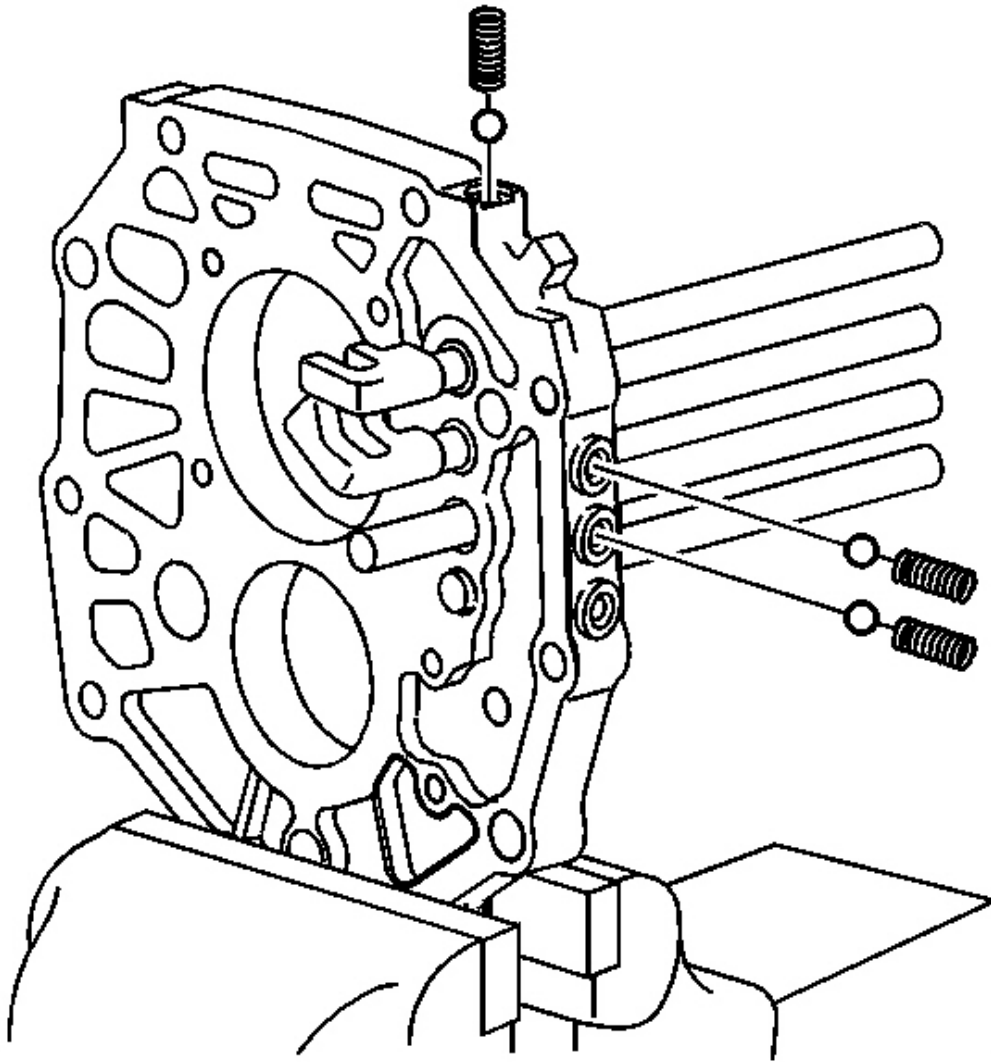

Fig. 82: View Of Shift Shaft Detent Springs & Balls
Courtesy of GENERAL MOTORS CORP.

53. Using a magnet, remove the 1st/2nd shift shaft detent spring and ball.
54. Using a magnet, remove the 3rd/4th shift shaft detent spring and ball.
55. Using a magnet, remove the 5th shift shaft detent spring and ball. The reverse shift shaft does

not have a detent spring and ball in the plug opening.

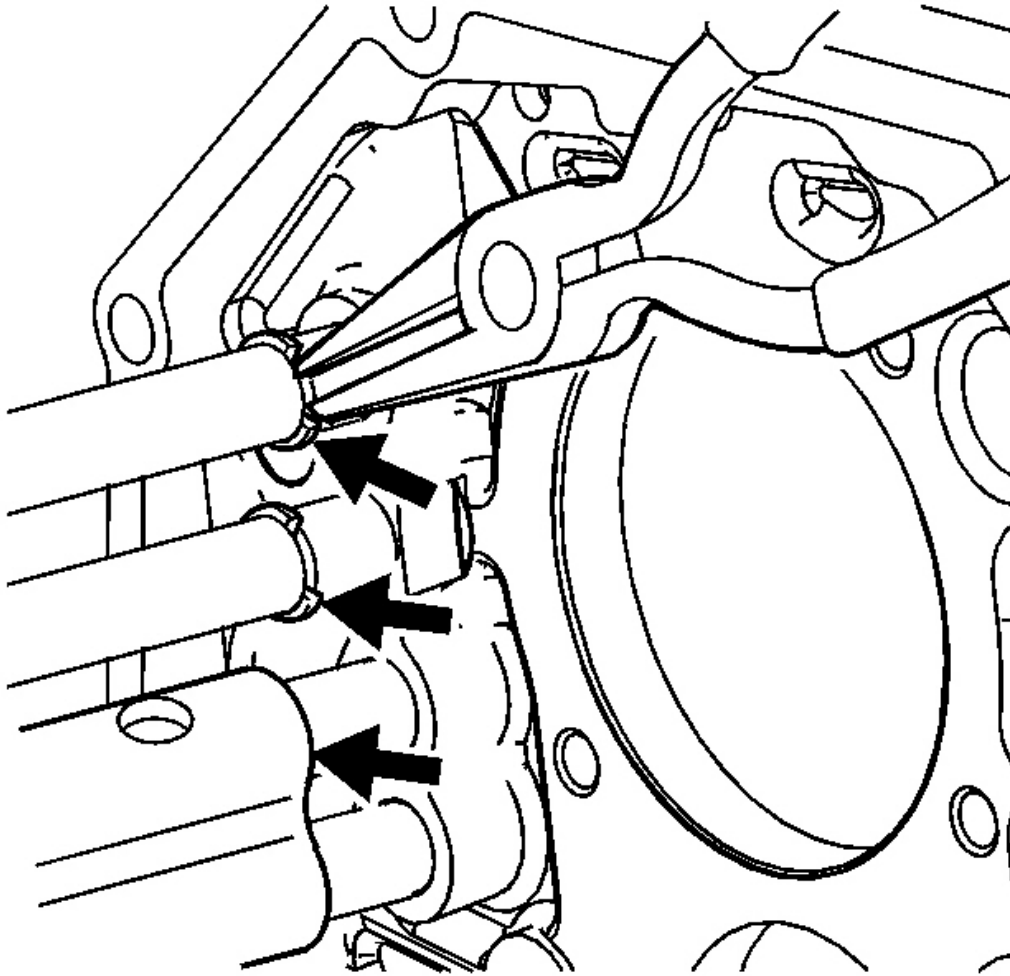

Fig. 83: Locating Shift Shaft Retaining Rings
Courtesy of GENERAL MOTORS CORP.

IMPORTANT: To prevent the retaining rings from flying, cover the area with a rag.

56. Remove the following shift shaft retaining rings:
- The 1st/2nd shift shaft
 - The 3rd/4th shift shaft

- The 5th shift shaft
 - Use a suitable pair of pliers to push the retaining ring.
 - Only push the retaining ring partially off to keep it from flying.
 - Use a pair of pliers to remove the retaining ring the rest of the way.

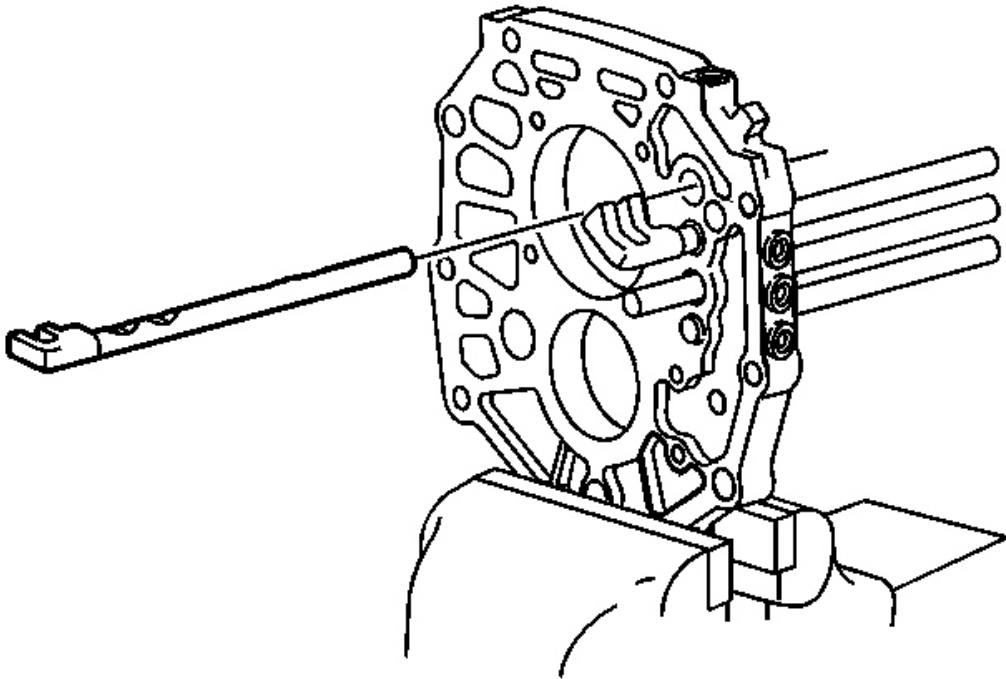

Fig. 84: Identifying 3rd/4th Shift Shaft
Courtesy of GENERAL MOTORS CORP.

57. Remove the 3rd/4th shift shaft.

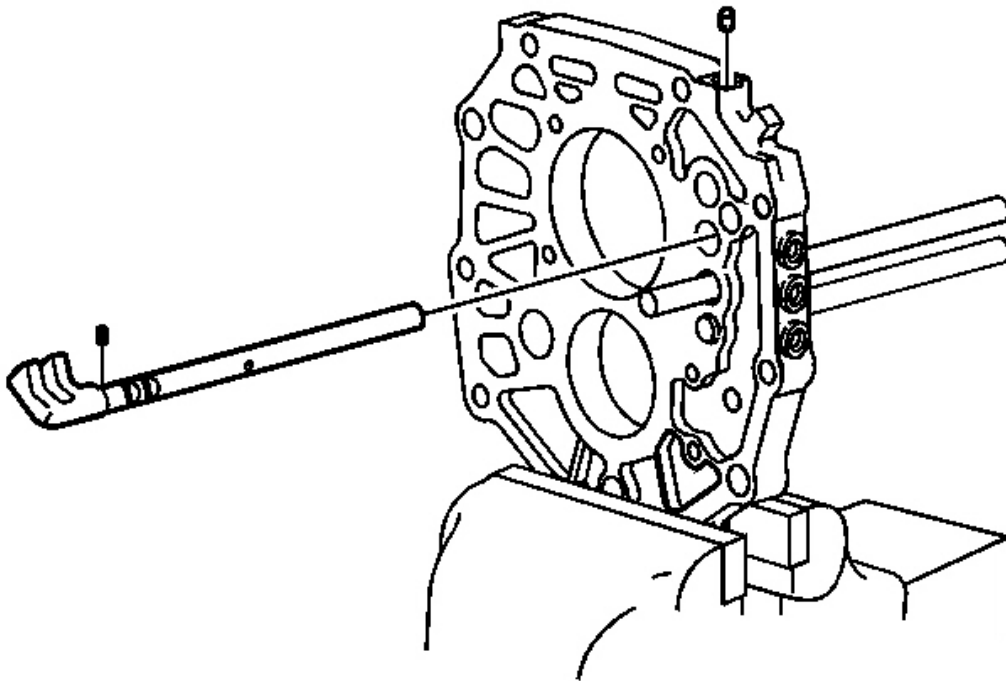

Fig. 85: Locating 1st/2nd Shift Shaft
Courtesy of GENERAL MOTORS CORP.

58. Using a magnet, remove the 1st/2nd and 3rd/4th shift shaft interlock pin.
59. Remove the 1st/2nd shift shaft.
60. Remove the small interlock pin from the 1st/2nd shift shaft.

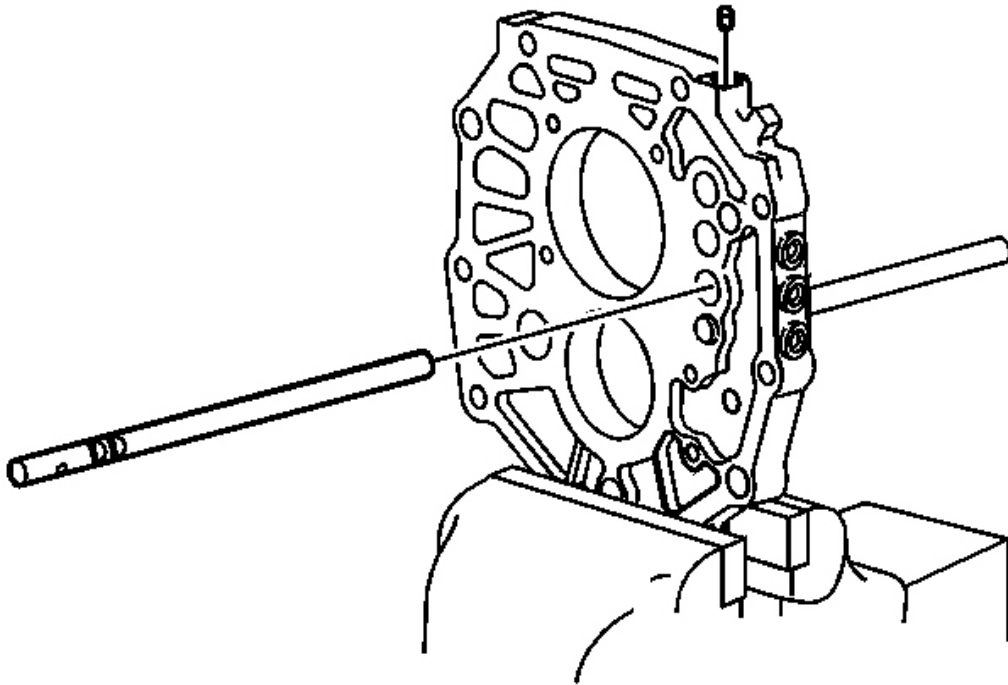

Fig. 86: View Of 5th Shift Shaft & Detent Ball
Courtesy of GENERAL MOTORS CORP.

61. Using a magnet, remove the 5th shift shaft and 1st/2nd shift shaft interlock pin.
62. Remove the 5th shift shaft.

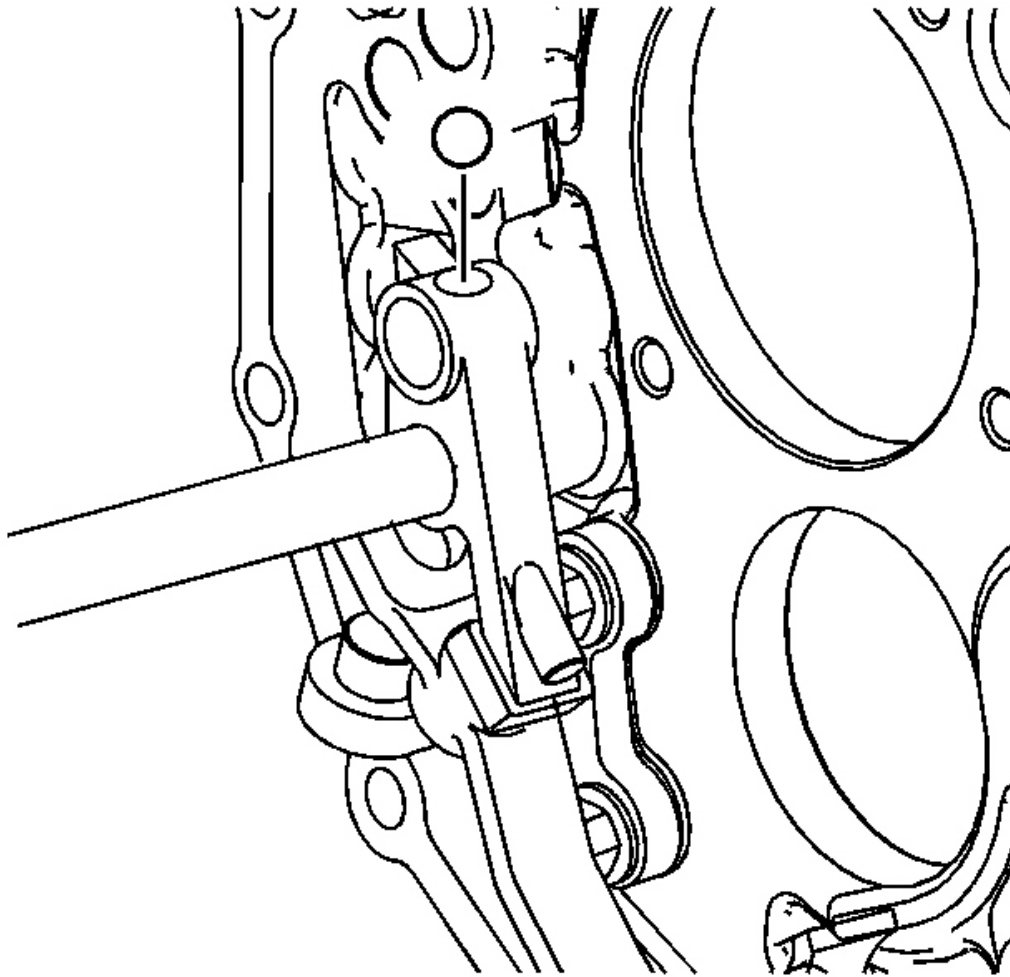

Fig. 87: Identifying Detent Ball In Reverse Shift Lever
Courtesy of GENERAL MOTORS CORP.

63. Remove the detent ball from the reverse shift lever.

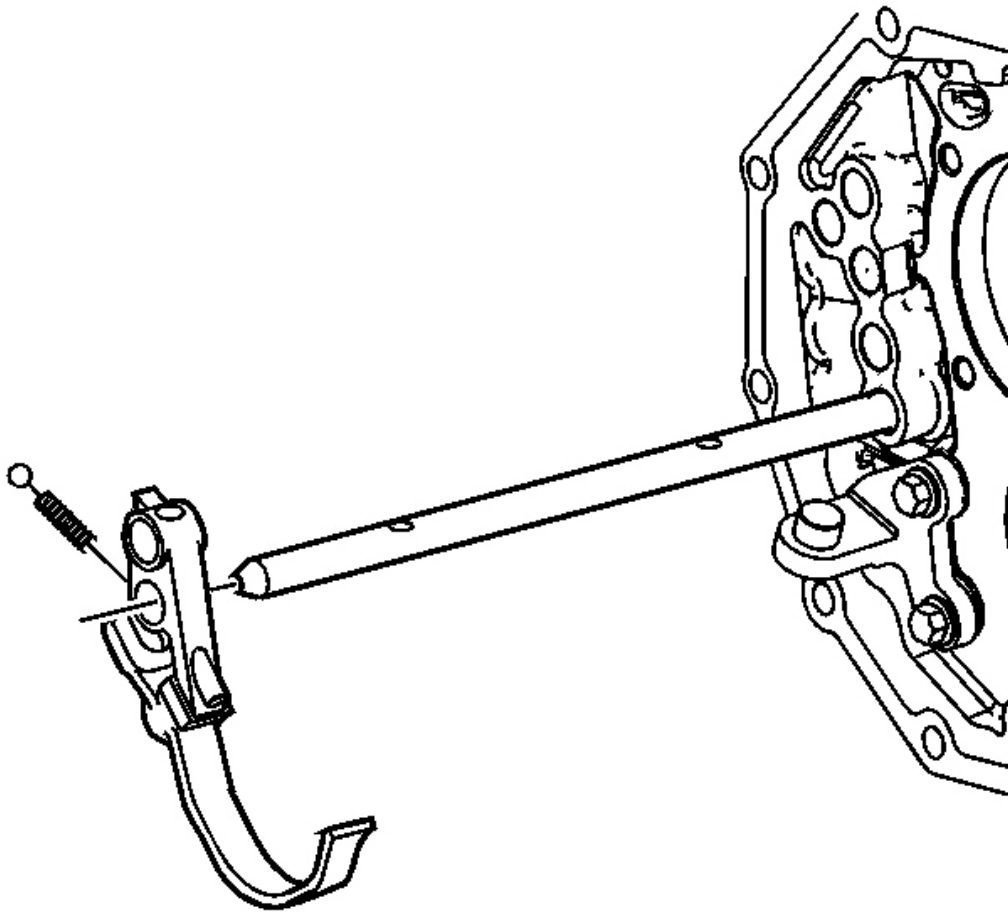

Fig. 88: Locating Detent Spring & Ball
Courtesy of GENERAL MOTORS CORP.

64. Remove the reverse shift lever, with the reverse shift fork, from the reverse shift shaft.
 1. Slide the shift lever to the end of the shaft.
 2. Cover the detent ball opening with your hand.
 3. Let the detent ball and spring land in your hand.

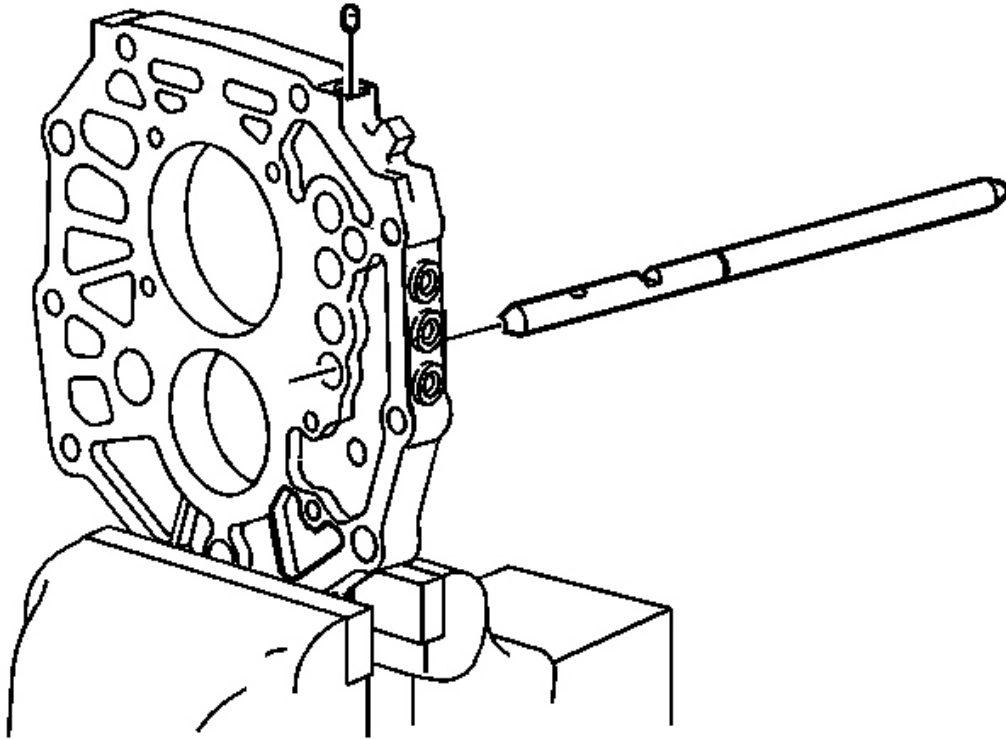

Fig. 89: Locating Reverse Gear Shift Shaft
Courtesy of GENERAL MOTORS CORP.

65. Using a magnet, remove the interlock pin from the reverse shift shaft. The shaft may require moving back and forth to remove the interlock pin.
66. Remove the reverse shift shaft.

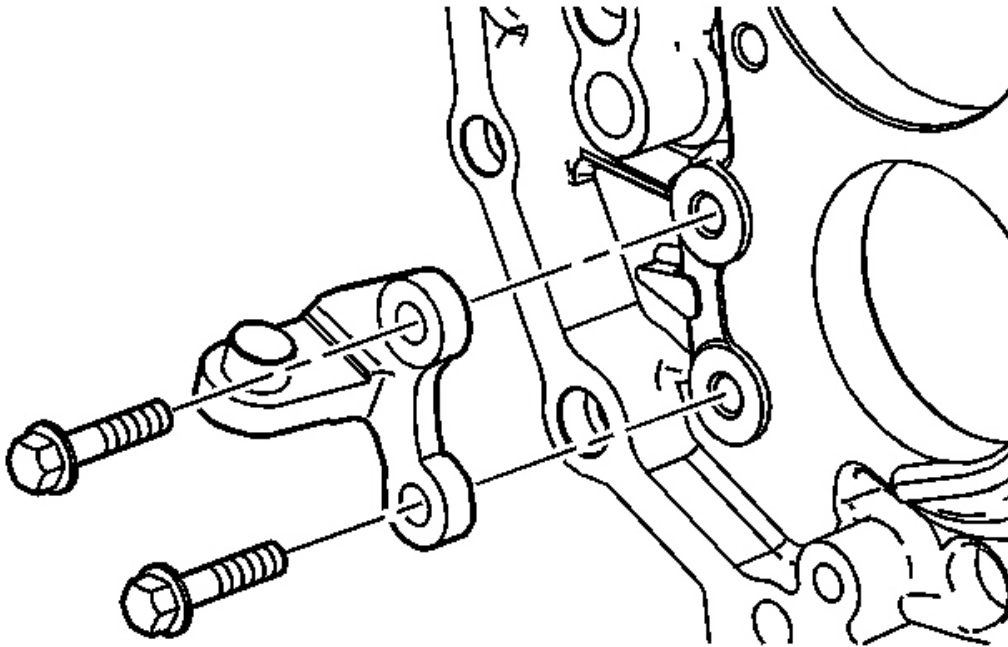

Fig. 90: View Of Reverse Shift Fork Bracket & Bolts
Courtesy of GENERAL MOTORS CORP.

67. Remove the bolts and the reverse shift fork bracket.

OUTPUT SHAFT DISASSEMBLE

Tools Required

- **J 8001-3** Dial Indicator
- **J 22912-B** Split-Plate Bearing Puller
- **J 26900-12** Dial Indicator - 1-10 mm. See **Special Tools**.
- **J 26900-13** Magnetic Indicator Base
- **J 45869** Gear Protector Plates. See **Special Tools**.

Disassembly Procedure

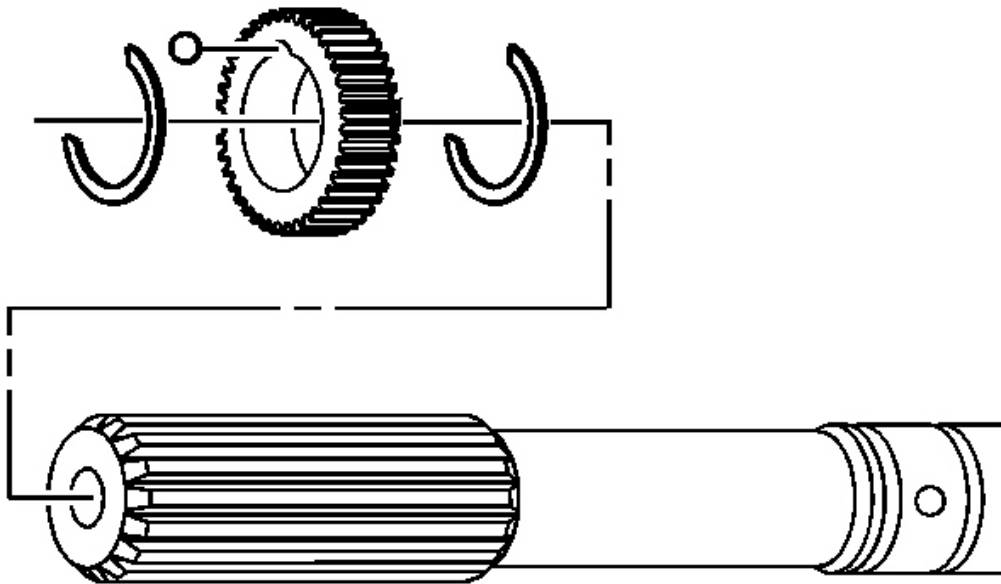

Fig. 91: View Of Speed Sensor Reluctor Wheel Front Retaining Ring, Wheel & Ball
Courtesy of GENERAL MOTORS CORP.

IMPORTANT: The following steps apply to both the 4WD and the RWD transmission, except where noted.

1. If RWD, remove the speed sensor reluctor wheel rear retaining ring.
2. Remove the speed sensor reluctor wheel.
3. Remove the speed sensor reluctor wheel locating ball.
4. Remove the speed sensor reluctor wheel front retaining ring.

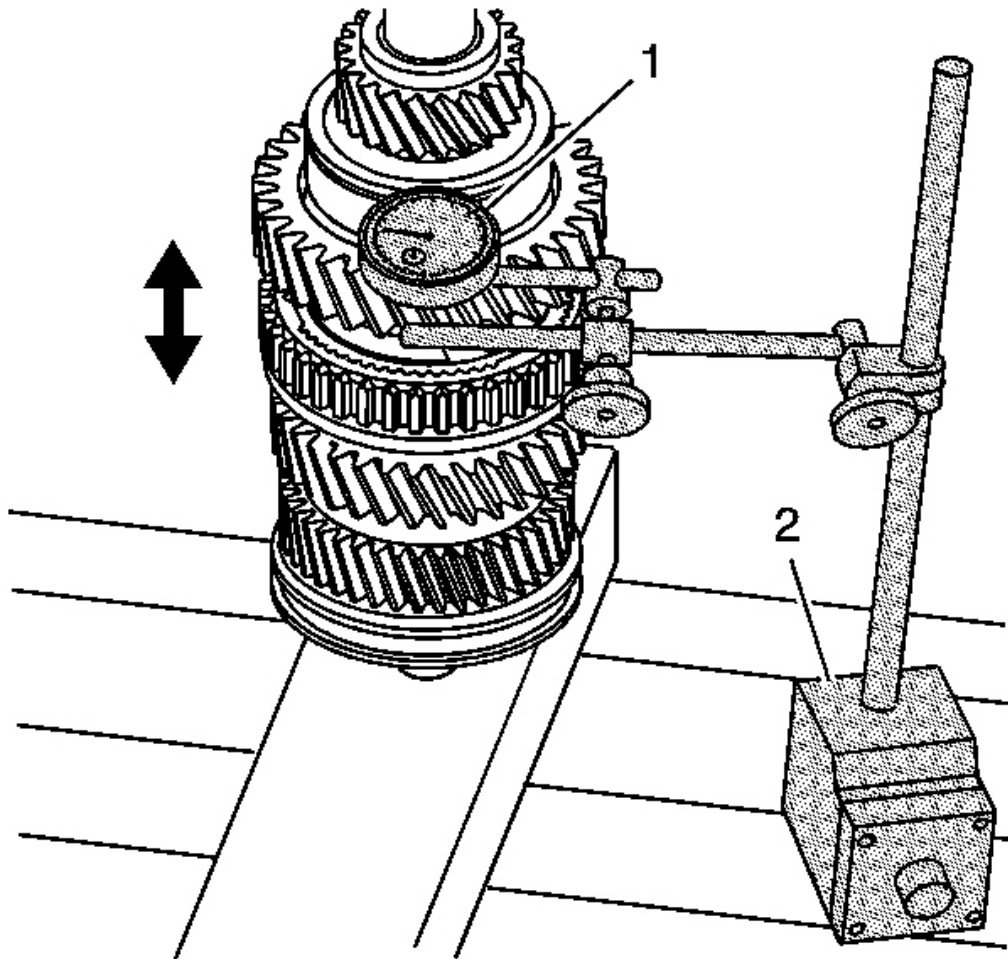

Fig. 92: Measuring 1st Gear Axial Play
Courtesy of GENERAL MOTORS CORP.

IMPORTANT: Before disassembly of the output shaft, measure the axial play of the speed gears. If axial play of the speed gears is incorrect, it may cause shifting concerns or transmission noise.

- Using J 8001-3 or J 26900-12 (1) and J 26900-13 (2), measure the 1st gear axial play. See Special Tools.

Specification:

- Standard Clearance: 0.20-0.45 mm (0.0079-0.0177 in)
 - Maximum Clearance: 0.50 mm (0.0197 in)
1. Position **J 8001-3** or **J 26900-12** (1) on the top of the gear teeth. See **Special Tools**.
 2. Zero the gage.
 3. Lift up on the gear to measure the clearance.
6. If the clearance exceeds the maximum, refer to **Gears and Shafts Cleaning and Inspection**.

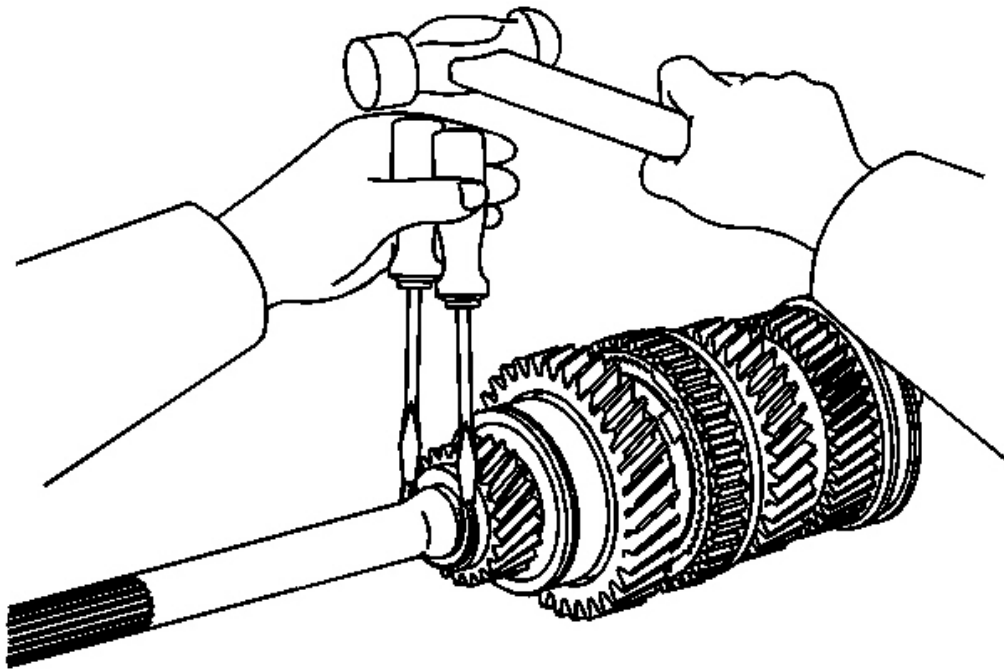

Fig. 93: Removing/Installing 5th Gear Retaining Ring
Courtesy of GENERAL MOTORS CORP.

7. Using 2 screwdrivers and a hammer, remove the 5th gear retaining ring.

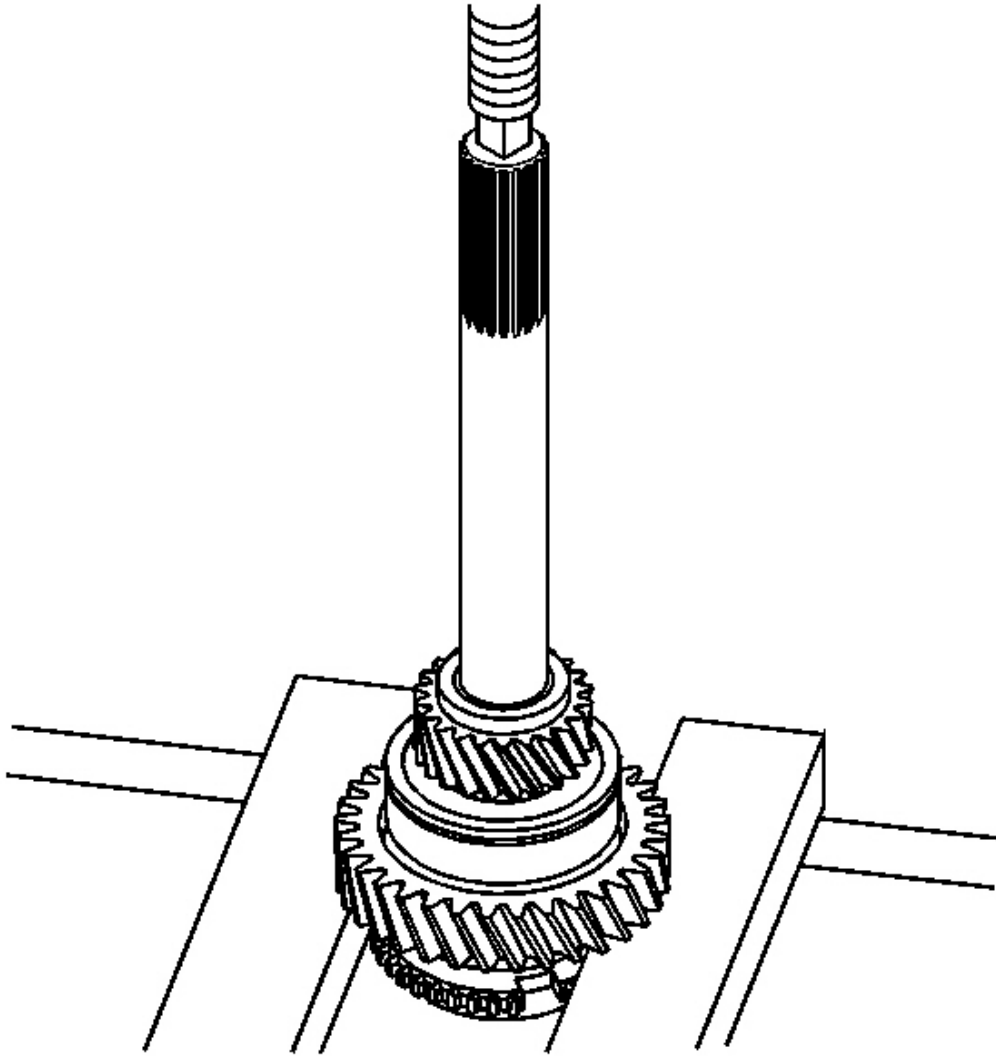

Fig. 94: Pressing Out 5th Gear And The Output Shaft Rear Bearing
Courtesy of GENERAL MOTORS CORP.

8. Using a hydraulic press, remove the 5th gear and the output shaft rear bearing.

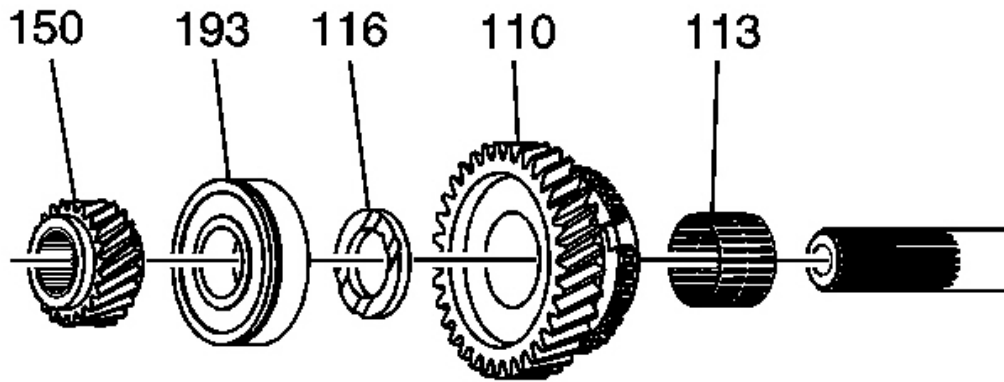

Fig. 95: Locating Output Shaft Components
Courtesy of GENERAL MOTORS CORP.

9. Remove the following components from the rear of the output shaft:
 - The 5th gear (150)
 - The output shaft rear bearing (193)
 - The 1st gear thrust washer (116)
 - The 1st gear (110)
 - The 1st gear bearing (113)

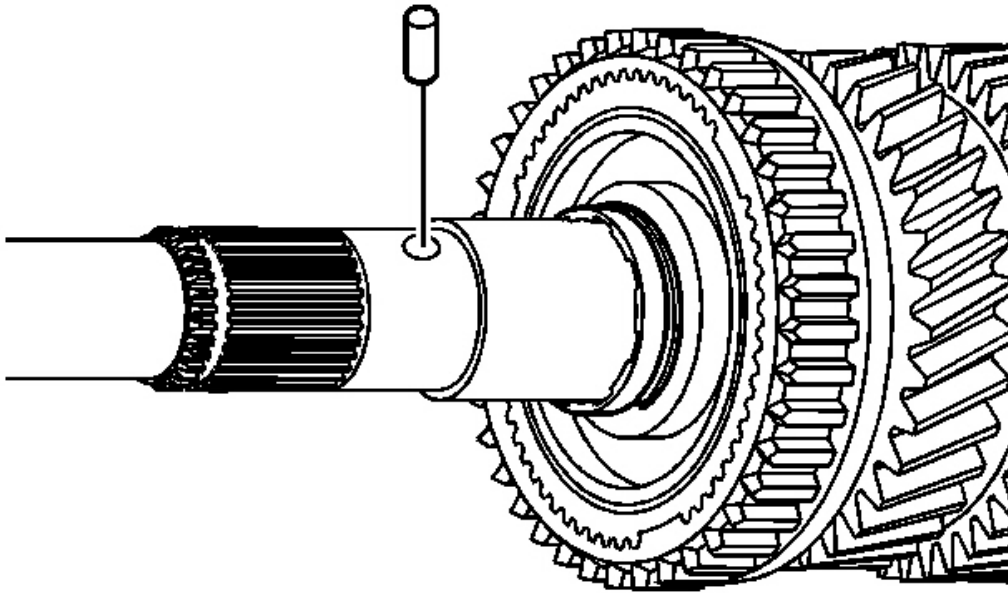

Fig. 96: Identifying 1st Gear Thrust Washer Lock Pin
Courtesy of GENERAL MOTORS CORP.

10. Remove the 1st gear thrust washer lock pin.

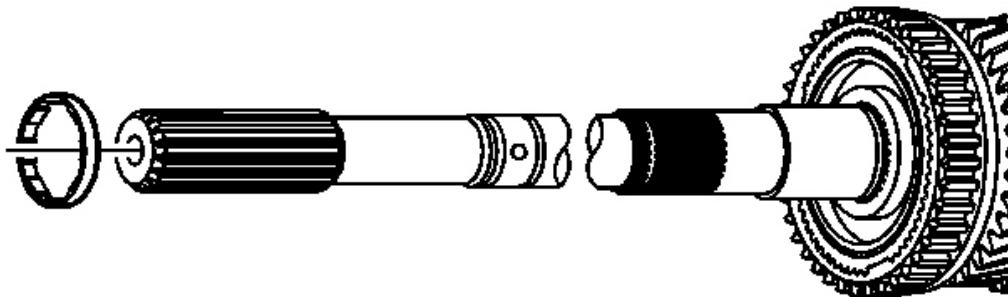

Fig. 97: View Of 1st Gear Spacer
Courtesy of GENERAL MOTORS CORP.

11. Remove the 1st gear bearing spacer.

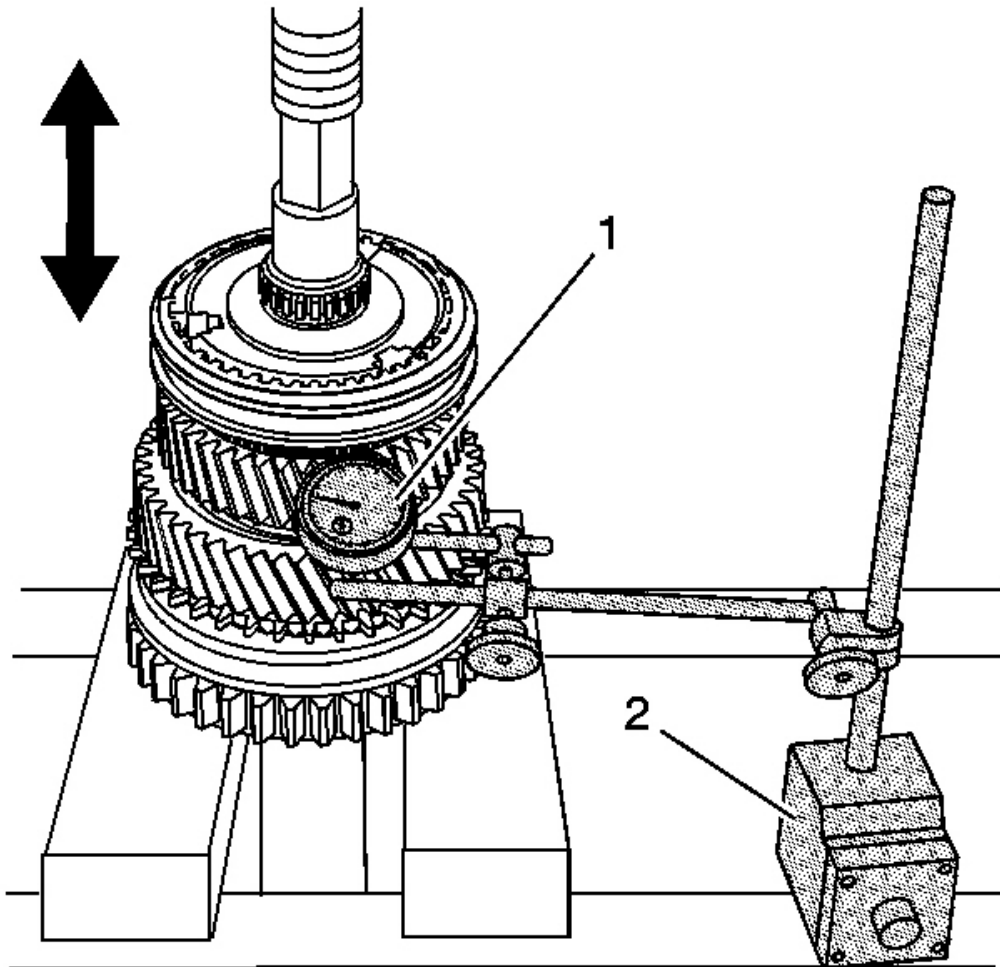

Fig. 98: Checking 2nd Gear Axial Play
Courtesy of GENERAL MOTORS CORP.

12. Using **J 8001-3** or **J 26900-12** (1) and **J 26900-13** (2), measure the 2nd gear axial play. See **Special Tools**.

Specification:

- Standard Clearance: 0.10-0.25 mm (0.0039-0.00098 in)
- Maximum Clearance: 0.30 mm (0.0118 in)

2007 Hummer H3

2007 TRANSMISSION Manual Transmission - Aisin AR5 - H3

1. Position **J 8001-3** or **J 26900-12** (1) on the top of the gear teeth. See **Special Tools**.
 2. Zero the gage.
 3. Lift up on the gear to measure the clearance.
13. If the clearance exceeds the maximum, refer to **Gears and Shafts Cleaning and Inspection**.

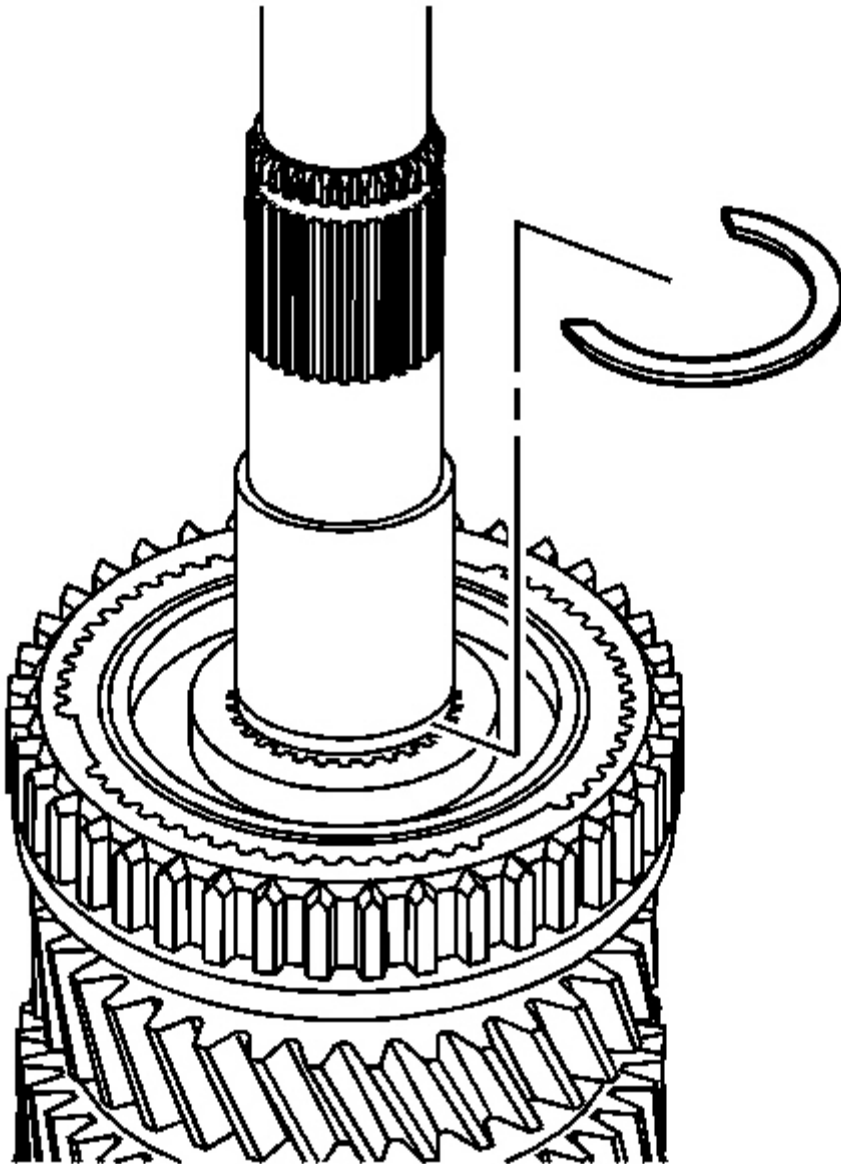

Fig. 99: View Of 1st/2nd Synchronizer Hub Retaining Ring
Courtesy of GENERAL MOTORS CORP.

14. Using 2 screwdrivers and a hammer, remove the 1st/2nd synchronizer hub retaining ring.

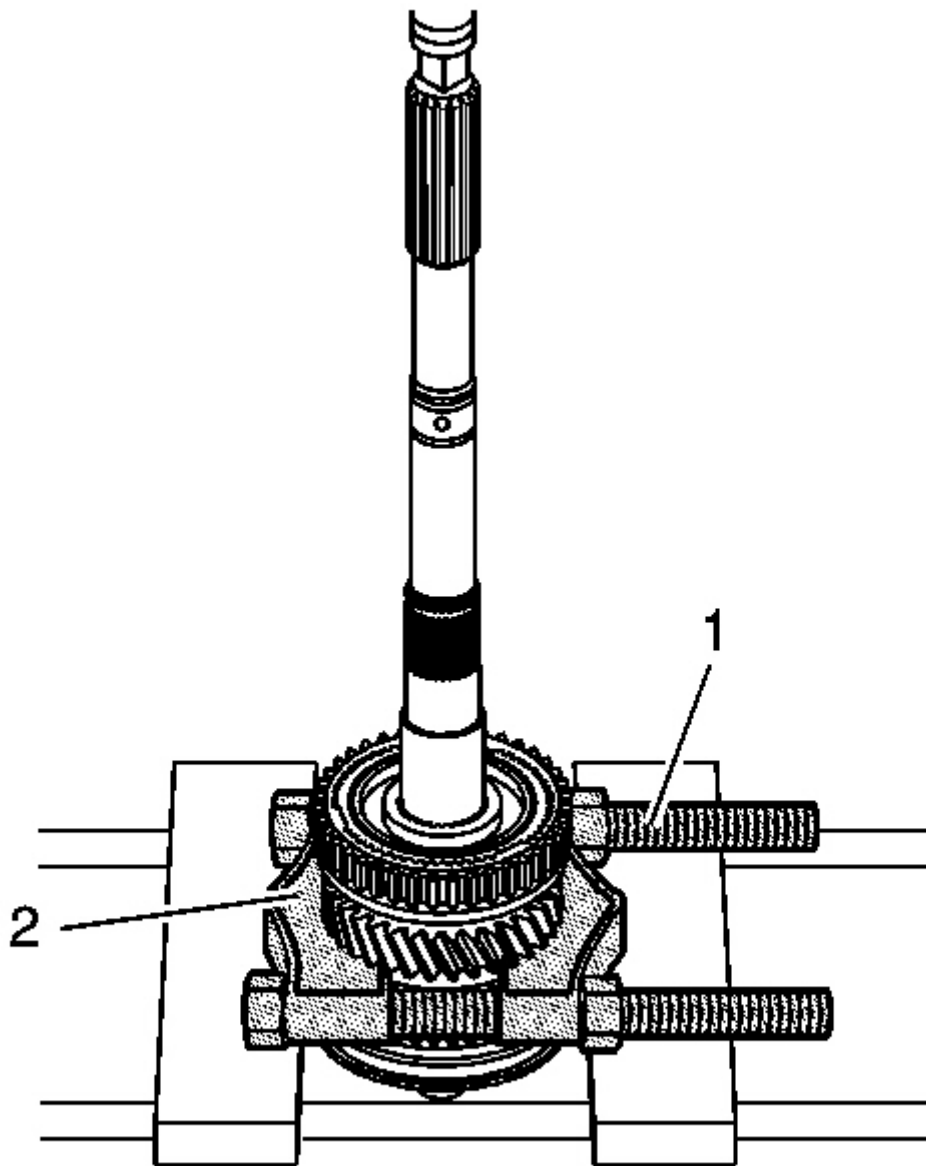

Fig. 100: Removing 1st/2nd Gear Synchronizer Hub Using J 45869 & J 22912-01
Courtesy of GENERAL MOTORS CORP.

NOTE: Protect the speed gear teeth when removing the synchronizer hubs to prevent damage to the gear.

15. Install the **J 45869** (1) onto the **J 22912-B** (2) to protect the gear teeth from chipping. See **Special Tools**.
16. Install the **J 22912-B** (2) with the **J 45869** (1) under 2nd gear. See **Special Tools**.
17. Using a hydraulic press, remove the 1st/2nd gear synchronizer hub.

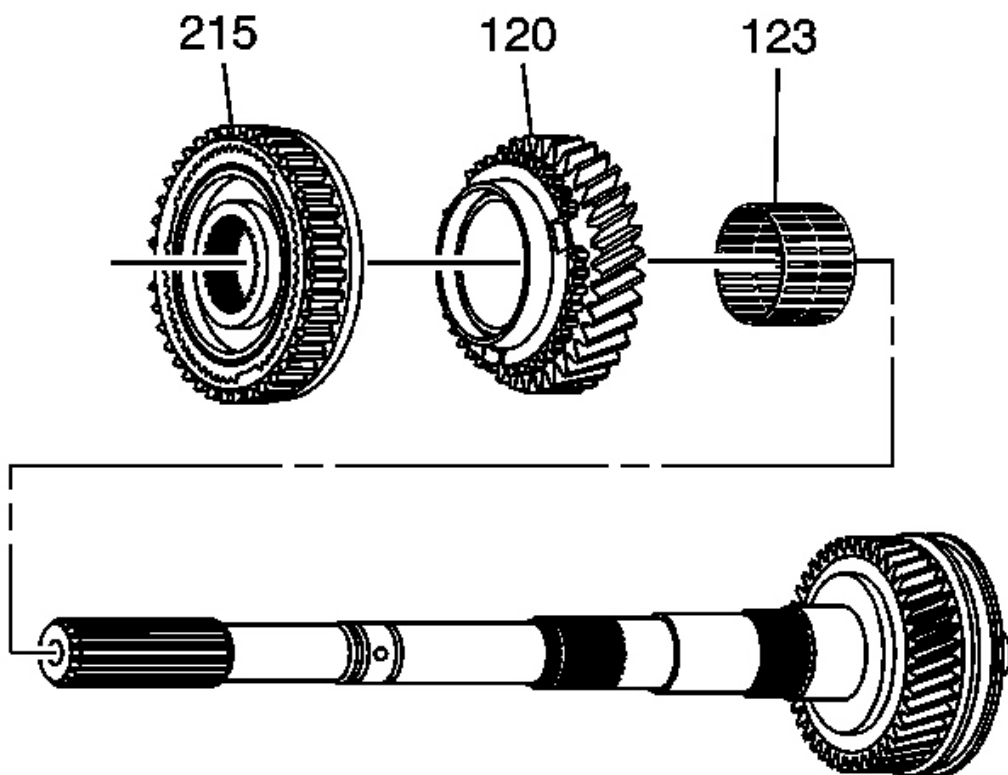

Fig. 101: View Of 1st/2nd Synchronizer Hub Assembly, 2nd Gear & Bearing
Courtesy of GENERAL MOTORS CORP.

18. Remove the following components from the rear of the output shaft:
 - The 1st/2nd gear synchronizer hub assembly (215)
 - The 2nd gear (120)
 - The 2nd gear bearing (123)

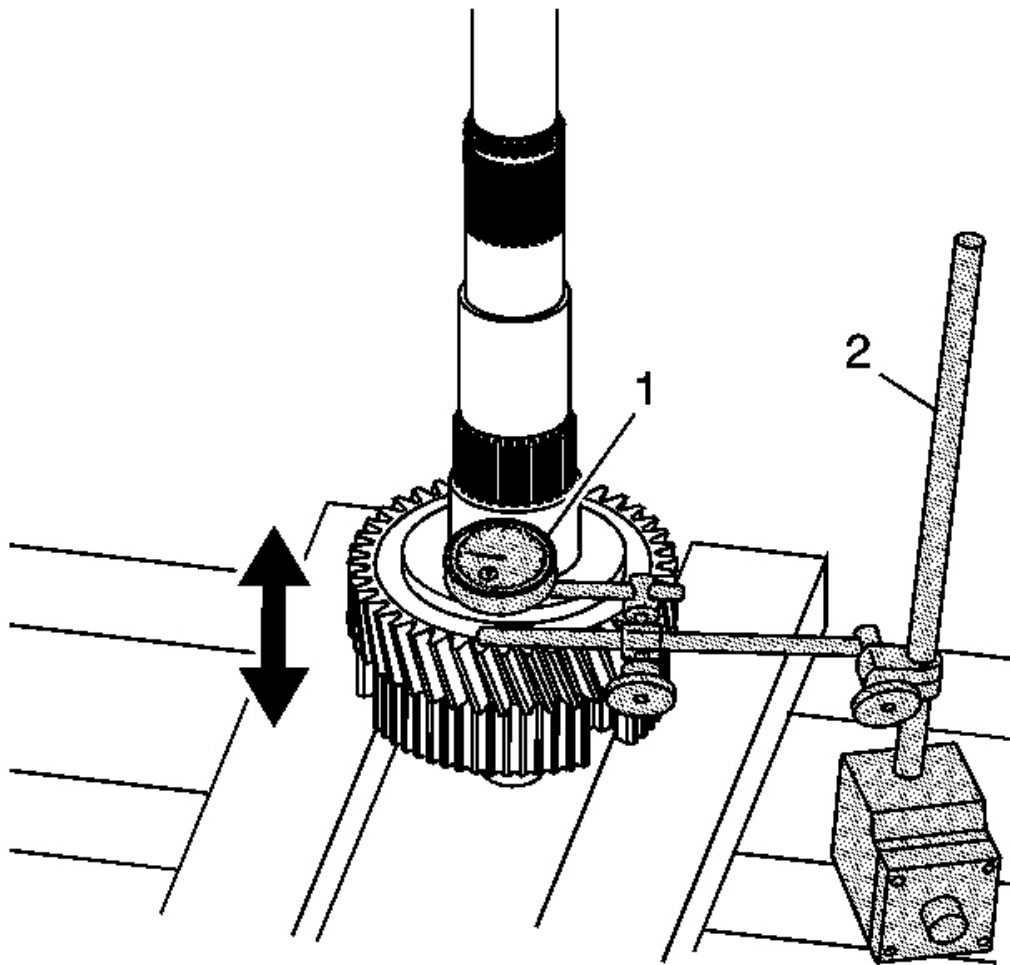

Fig. 102: Measuring 3rd Gear Axial Play
Courtesy of GENERAL MOTORS CORP.

19. Using **J 8001-3** or **J 26900-12** (1) and **J 26900-13** (2), measure the 3rd gear axial play. See **Special Tools**.

Specification:

- Standard Clearance: 0.10-0.25 mm (0.0039-0.00098 in)
- Maximum Clearance: 0.30 mm (0.0118 in)

1. Position **J 8001-3** or **J 26900-12** (1) on the top of the gear teeth. See **Special Tools**.

2. Zero the gage.
 3. Lift up on the gear to measure the clearance.
20. If the clearance exceeds the maximum, refer to **Gears and Shafts Cleaning and Inspection**.

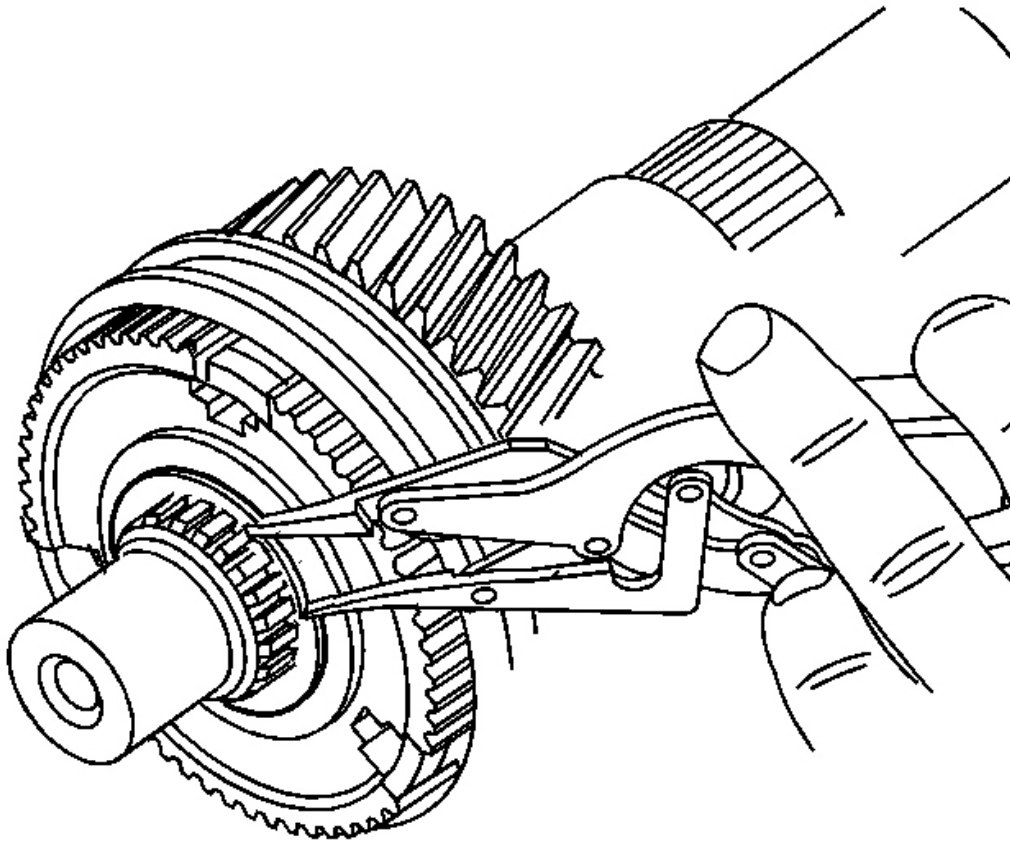

Fig. 103: Locating 3rd/4th Gear Synchronizer Hub Retaining Ring
Courtesy of GENERAL MOTORS CORP.

IMPORTANT: The 3rd/4th gear synchronizer hub cannot be used again if removed. A new hub is required for assembly.

21. Remove the 3rd/4th gear synchronizer hub retaining ring.

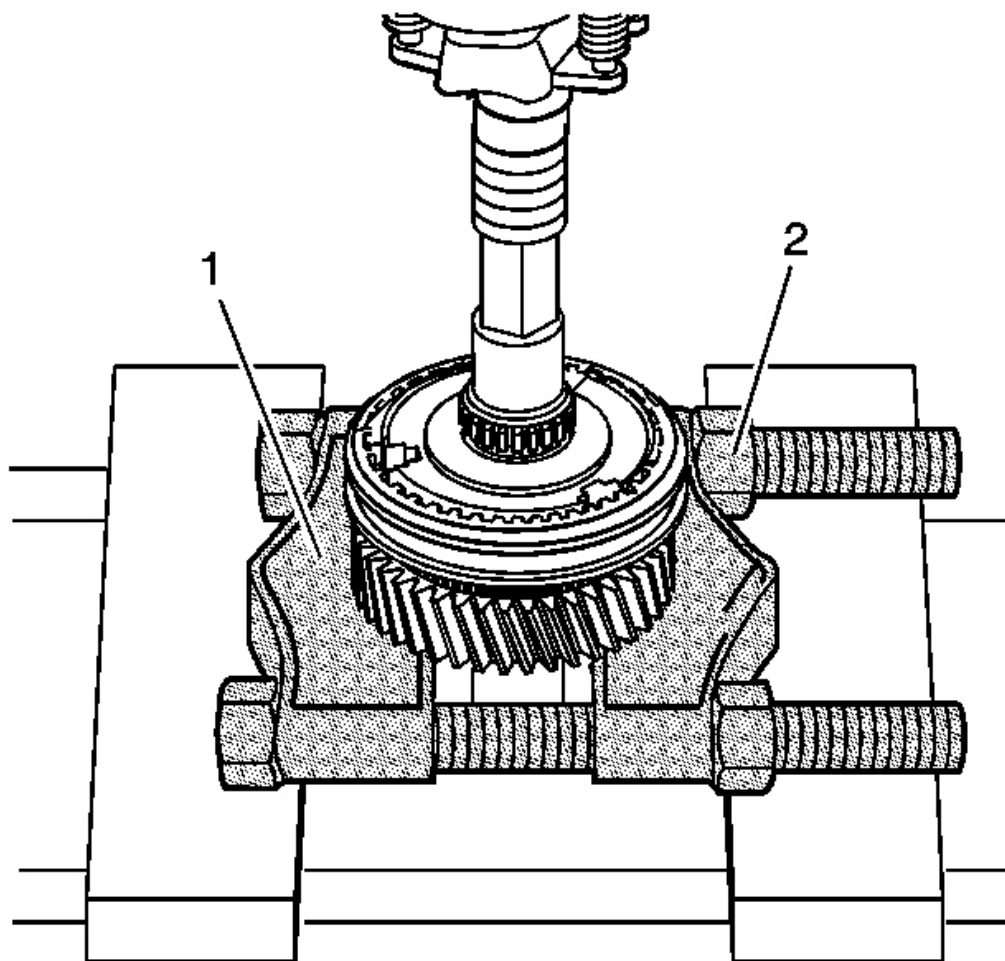

Fig. 104: Removing The 3rd/4th Gear Synchronizer Hub Using J 22912-01 & J 45869
Courtesy of GENERAL MOTORS CORP.

NOTE: Protect the speed gear teeth when removing the synchronizer hubs to prevent damage to the gear.

22. Install the **J 22912-B** (2) with the **J 45869** (1) under the 3rd gear. See **Special Tools**.
23. Using a hydraulic press, remove the 3rd/4th gear synchronizer hub.

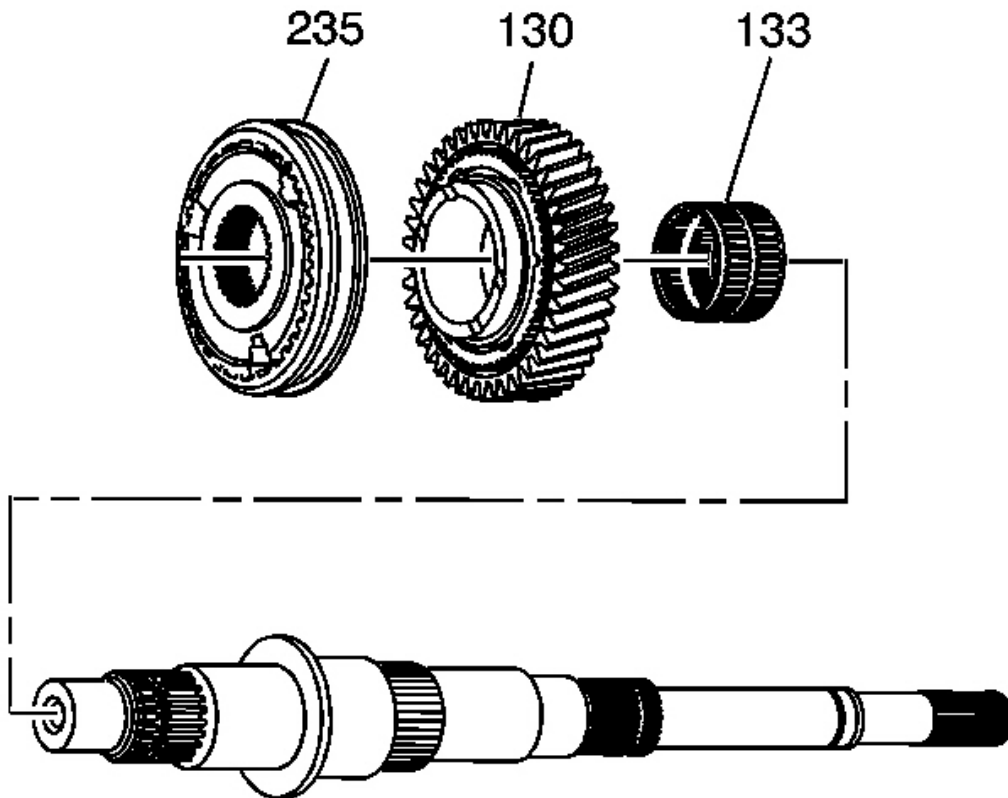

Fig. 105: Identifying Output Shaft Components
Courtesy of GENERAL MOTORS CORP.

24. Remove the following components from the front of the output shaft:
- The 3rd/4th gear synchronizer hub assembly (235)
 - The 3rd gear (130)
 - The 3rd gear bearing (133)

INPUT SHAFT DISASSEMBLE

Tools Required

J 22912-B Split-Plate Bearing Puller

Disassembly Procedure

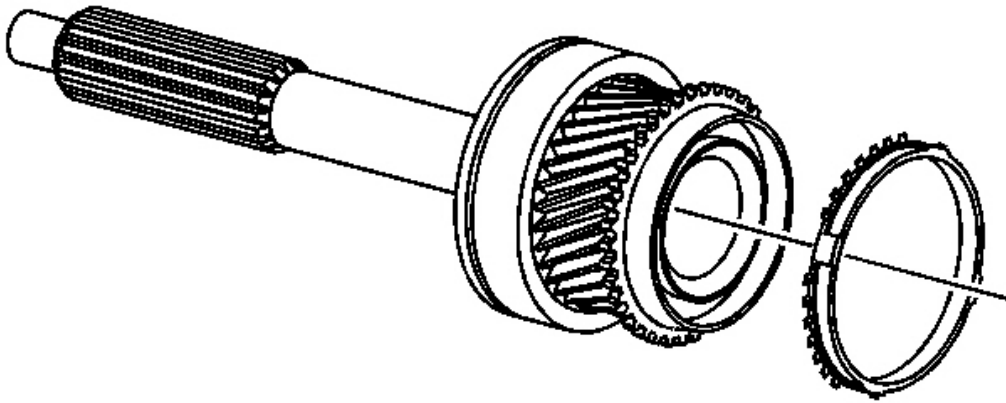

Fig. 106: View Of 4th Gear Blocking Ring
Courtesy of GENERAL MOTORS CORP.

1. Remove the 4th gear blocking ring from the input shaft.

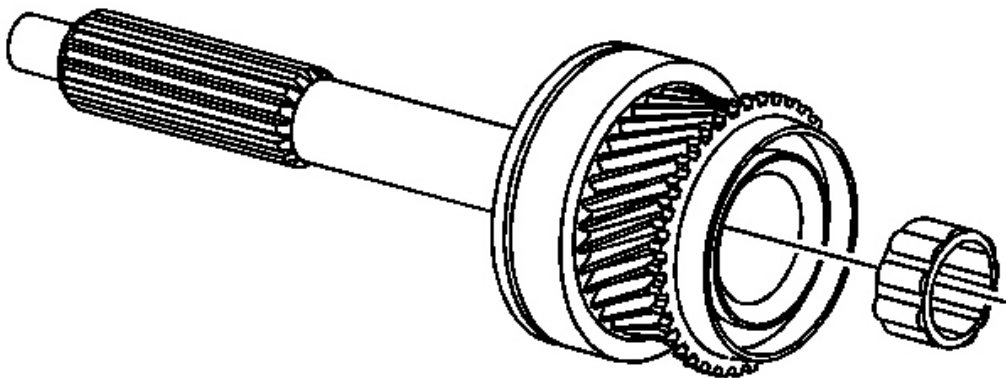

Fig. 107: Locating Output Front Support Bearing
Courtesy of GENERAL MOTORS CORP.

2. Remove the output shaft front support bearing from the input shaft.

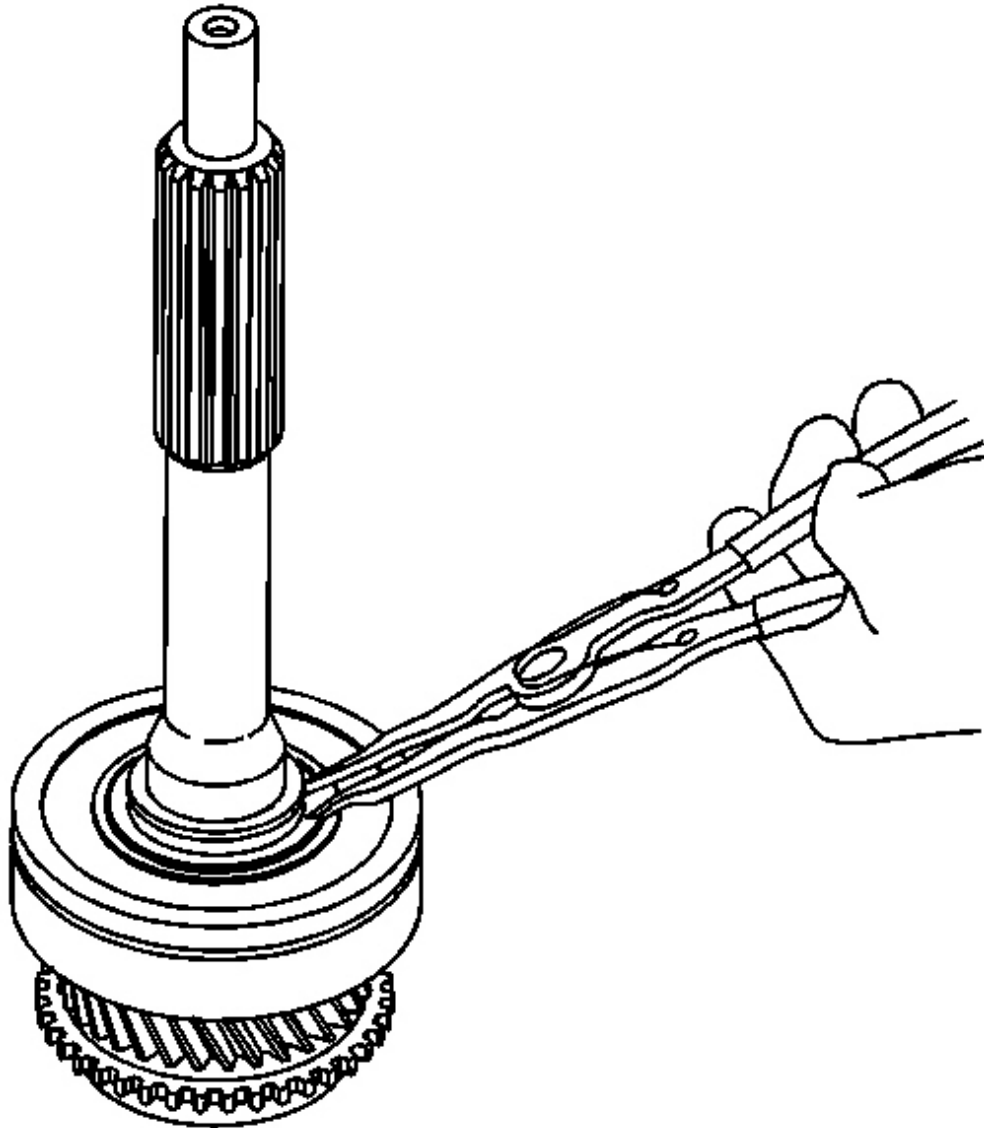

Fig. 108: Identifying Input Shaft Bearing Retaining Ring
Courtesy of GENERAL MOTORS CORP.

3. Inspect the input shaft bearing for being faulty. Refer to **Bearings and Spacers Cleaning and Inspection**.
4. If the bearing is faulty, remove the input shaft bearing retaining ring.

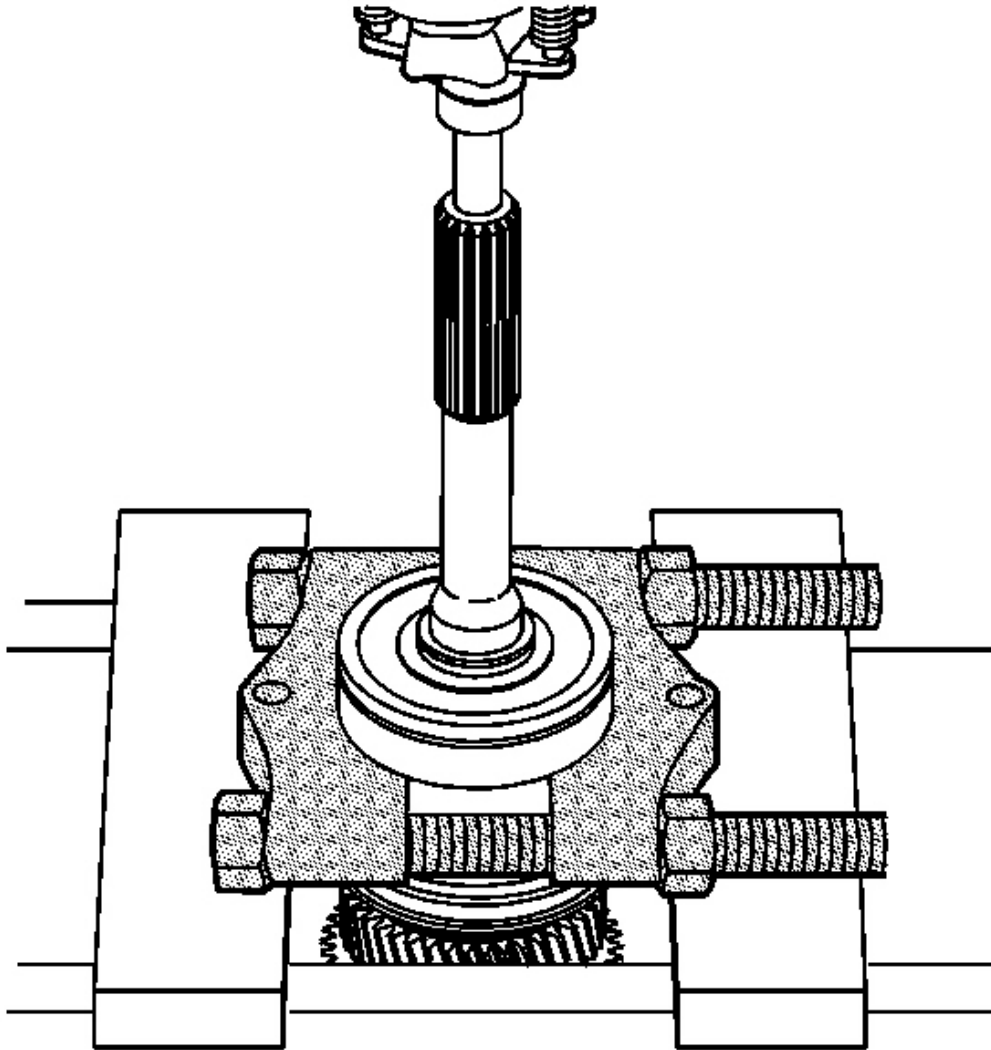

Fig. 109: Removing Input Shaft Bearing Using J 22912-01
Courtesy of GENERAL MOTORS CORP.

5. Using a hydraulic press and **J 22912-B** , remove the input shaft bearing. Discard the bearing. Do not use the bearing after removal.

COUNTER GEAR SHAFT DISASSEMBLE

Tools Required

J 22912-B Split-Plate Bearing Puller

Disassembly Procedure

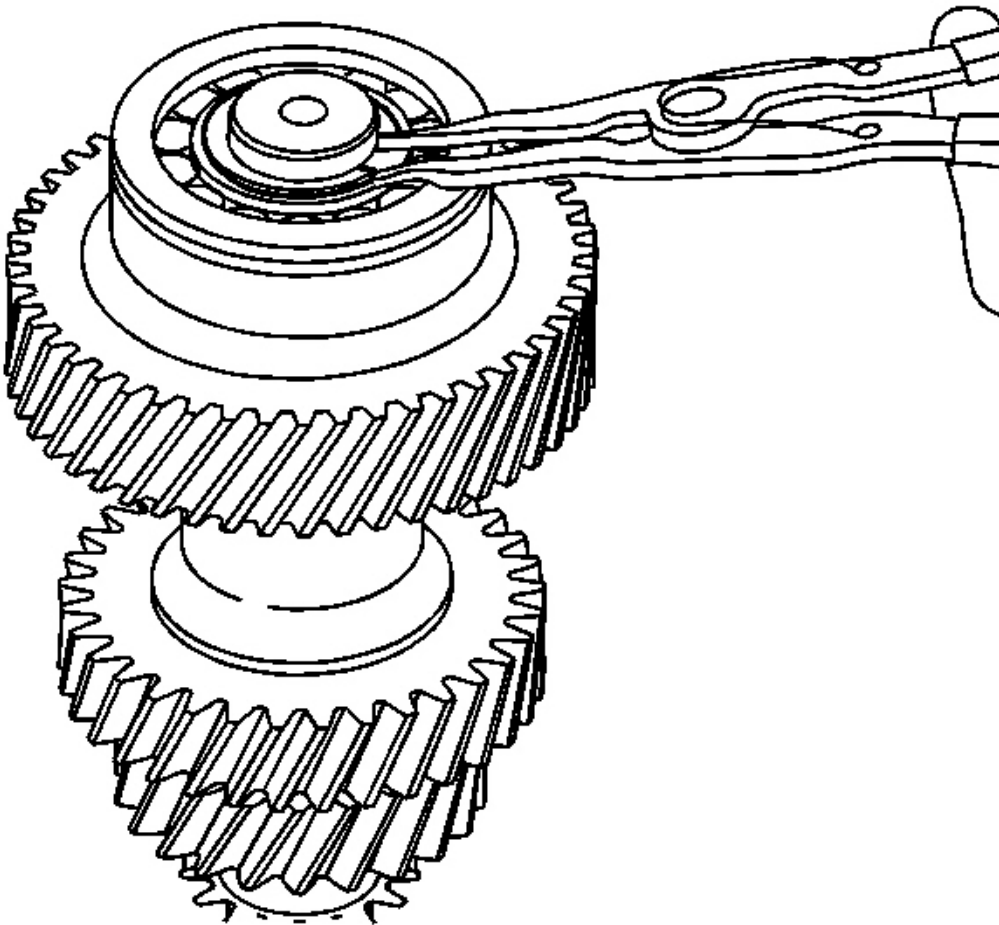

Fig. 110: Locating Countershaft Front Bearing Retaining Ring
Courtesy of GENERAL MOTORS CORP.

1. Inspect the countershaft front bearing for being faulty. Refer to **Bearings and Spacers Cleaning and Inspection**.
2. If the bearing is faulty, remove the countershaft front bearing retaining ring.

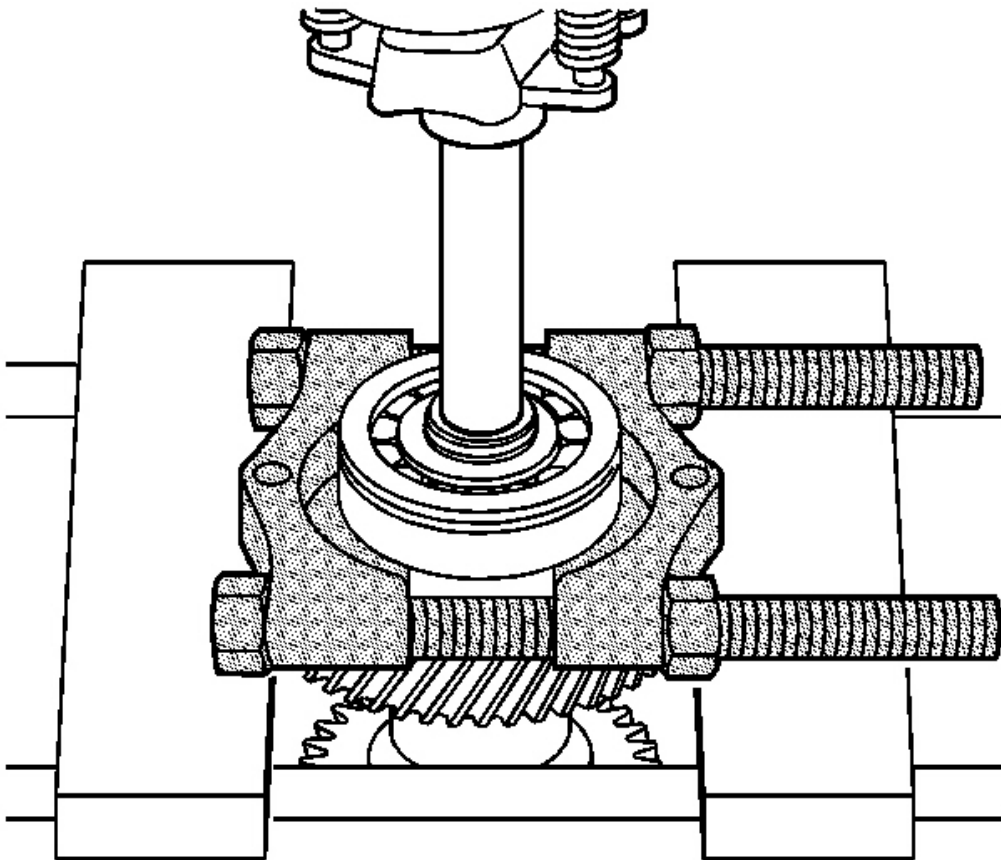

Fig. 111: Removing Front Bearing From The Countershaft Using J 22912-01
Courtesy of GENERAL MOTORS CORP.

3. Using a hydraulic press and J 22912-B , remove the front bearing from the countershaft.
4. Remove the bearing collar race from the countershaft.
5. Discard the bearing. Do not use the bearing after removal.

SHIFT CONTROL HOUSING DISASSEMBLE

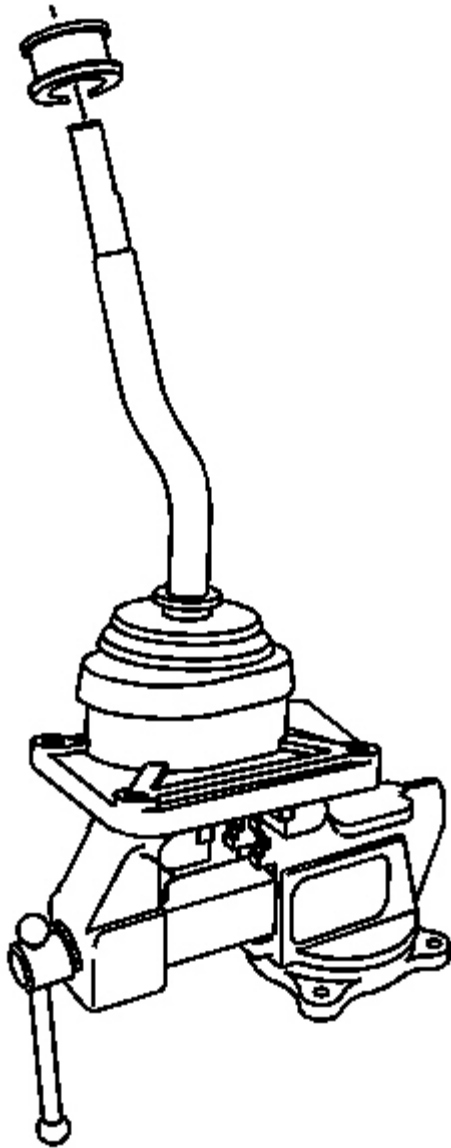

Fig. 112: Locating Shift Control Lever Shaft Seal
Courtesy of GENERAL MOTORS CORP.

1. Remove the shift control lever shaft seal by holding onto the seal and hitting the end of the shift control lever with a soft-face hammer.

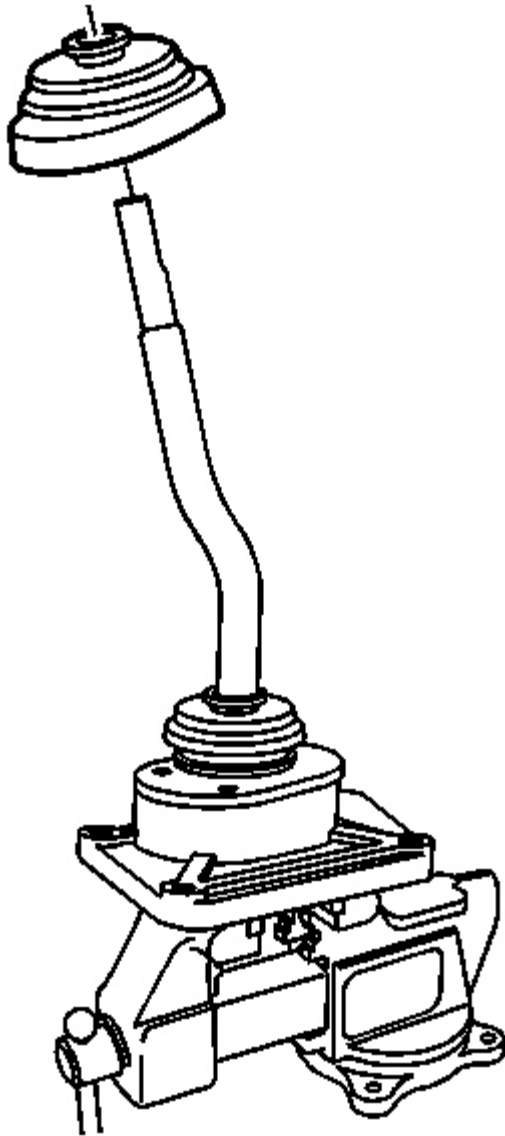

Fig. 113: Identifying Control Lever Boot
Courtesy of GENERAL MOTORS CORP.

2. Remove the control lever boot.

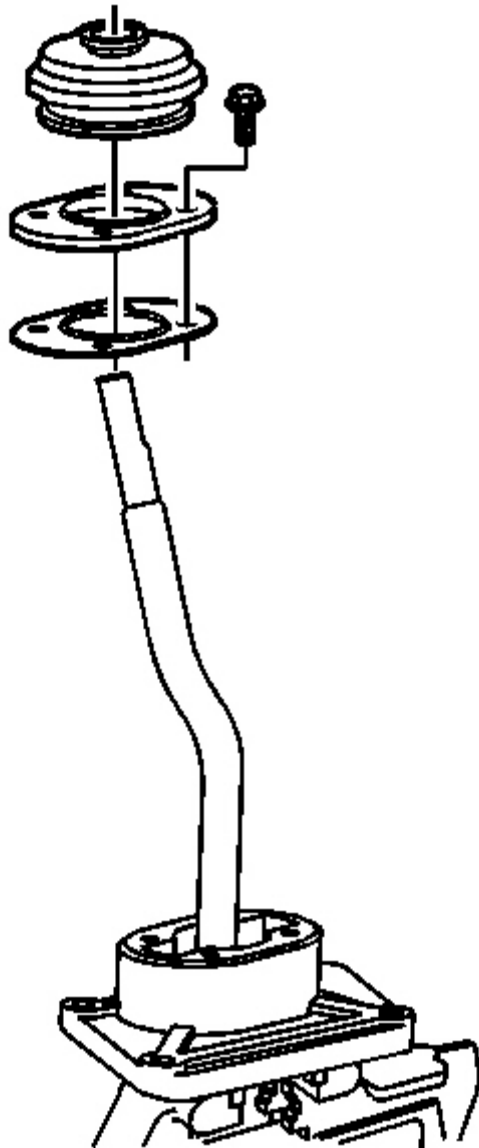

Fig. 114: View Of Shift Control Lever Retainer & Retaining Bolts
Courtesy of GENERAL MOTORS CORP.

3. Remove the shift control shaft boot from the shift control lever retainer.
4. Remove the shift control lever retainer bolts.

5. Remove the shift control lever retainer.
6. Remove the control lever housing gasket.

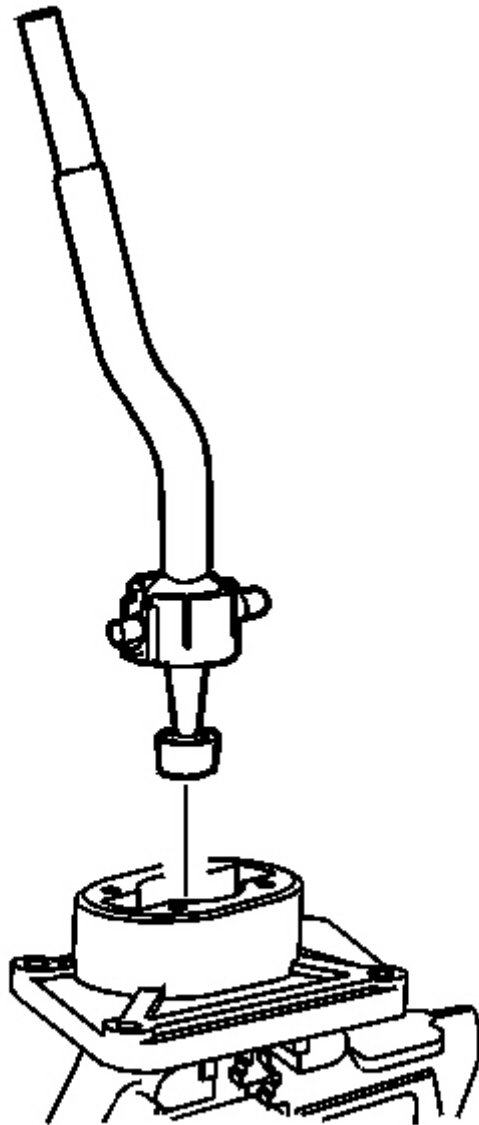

Fig. 115: Identifying Shift Control Lever Assembly
Courtesy of GENERAL MOTORS CORP.

7. Remove the shift control lever assembly from the shift control housing.

Do not remove the shift lever seat or bushing from the lever. The shift lever seat and bushing can only be serviced with the lever.

TRANSMISSION CASE DISASSEMBLE

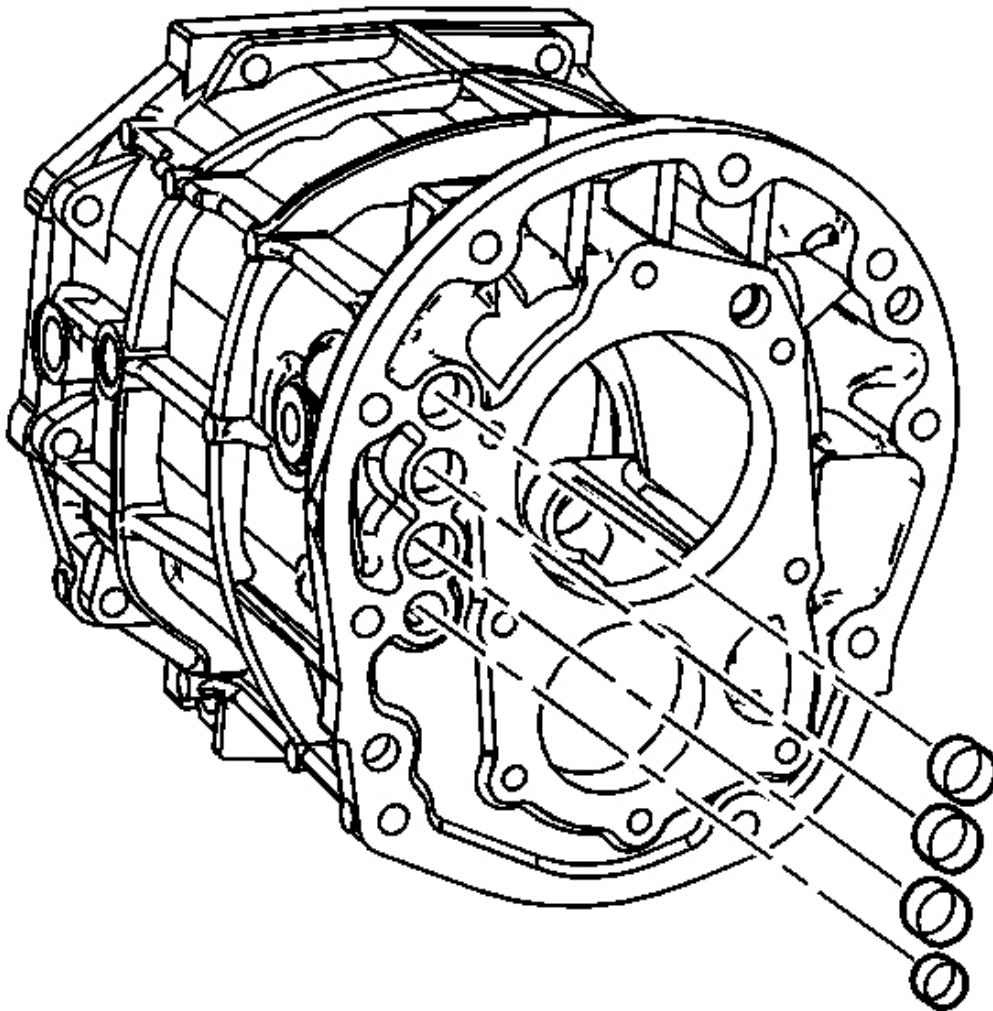

Fig. 116: Locating Shift Shaft Plugs In Transmission Front Case
Courtesy of GENERAL MOTORS CORP.

If required, using a suitable punch, remove the shift shaft plugs from the front case.

TRANSMISSION EXTENSION DISASSEMBLE

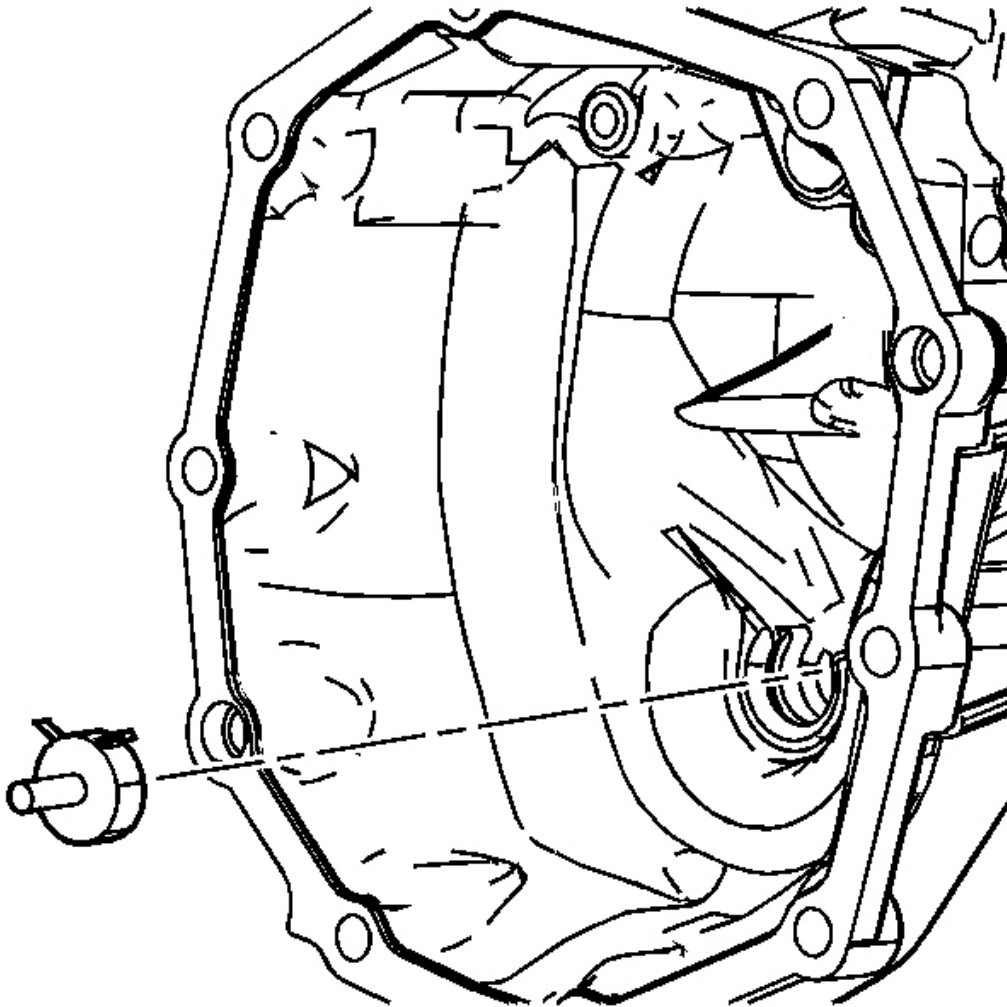

Fig. 117: Locating Oil Receiver
Courtesy of GENERAL MOTORS CORP.

1. Remove the oil receiver.

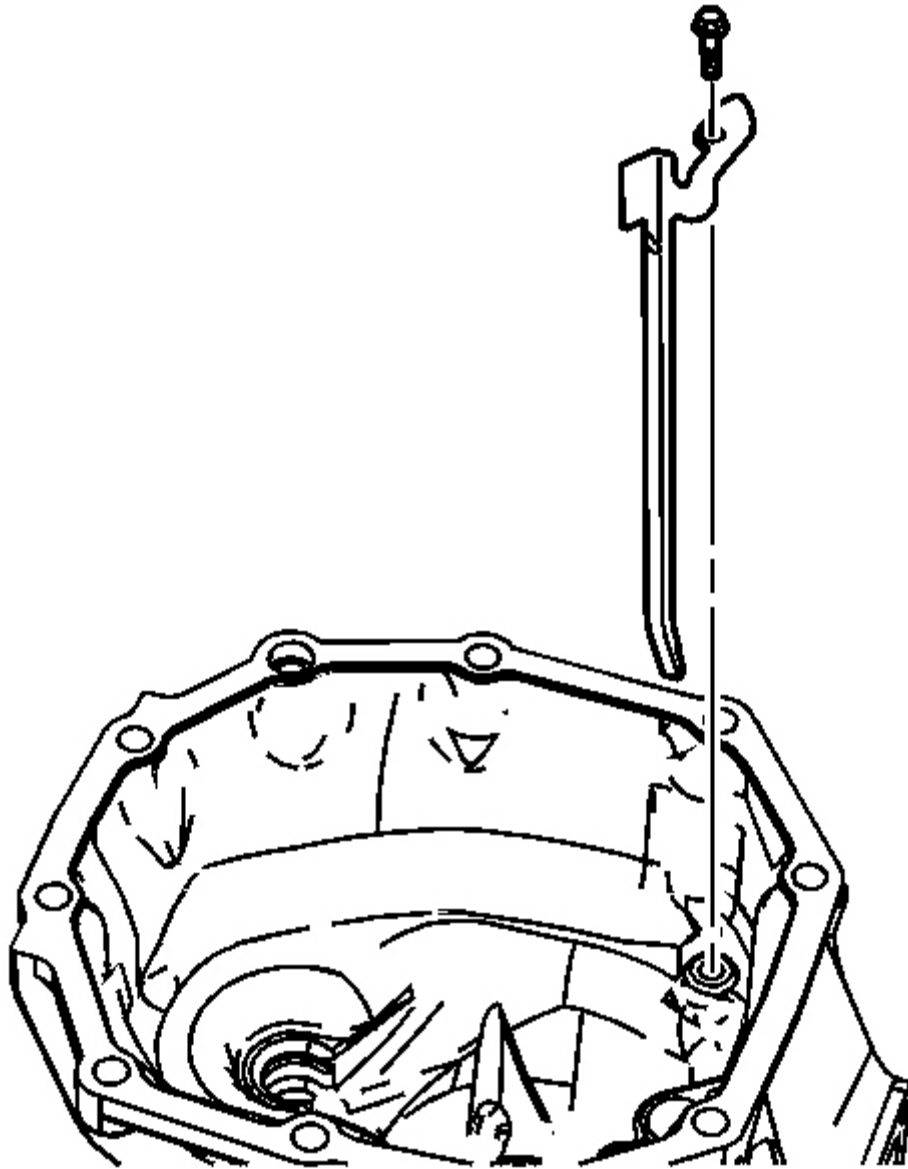

Fig. 118: Identifying Oil Trough & Mounting Bolt
Courtesy of GENERAL MOTORS CORP.

2. If RWD, remove the oil trough bolt.
3. Remove the oil trough.

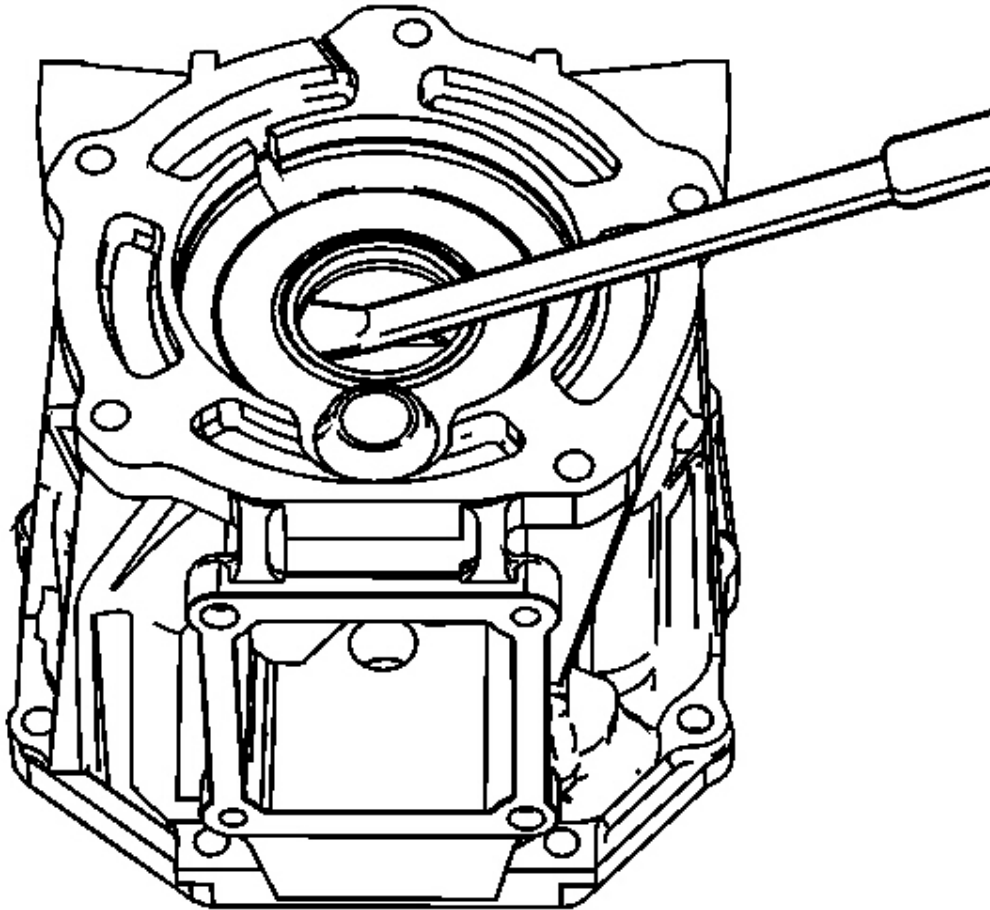

Fig. 119: Removing Output Shaft Seal - 4WD
Courtesy of GENERAL MOTORS CORP.

4. For the 4WD transmission, using a suitable prying tool, remove the output shaft seal from the extension housing.

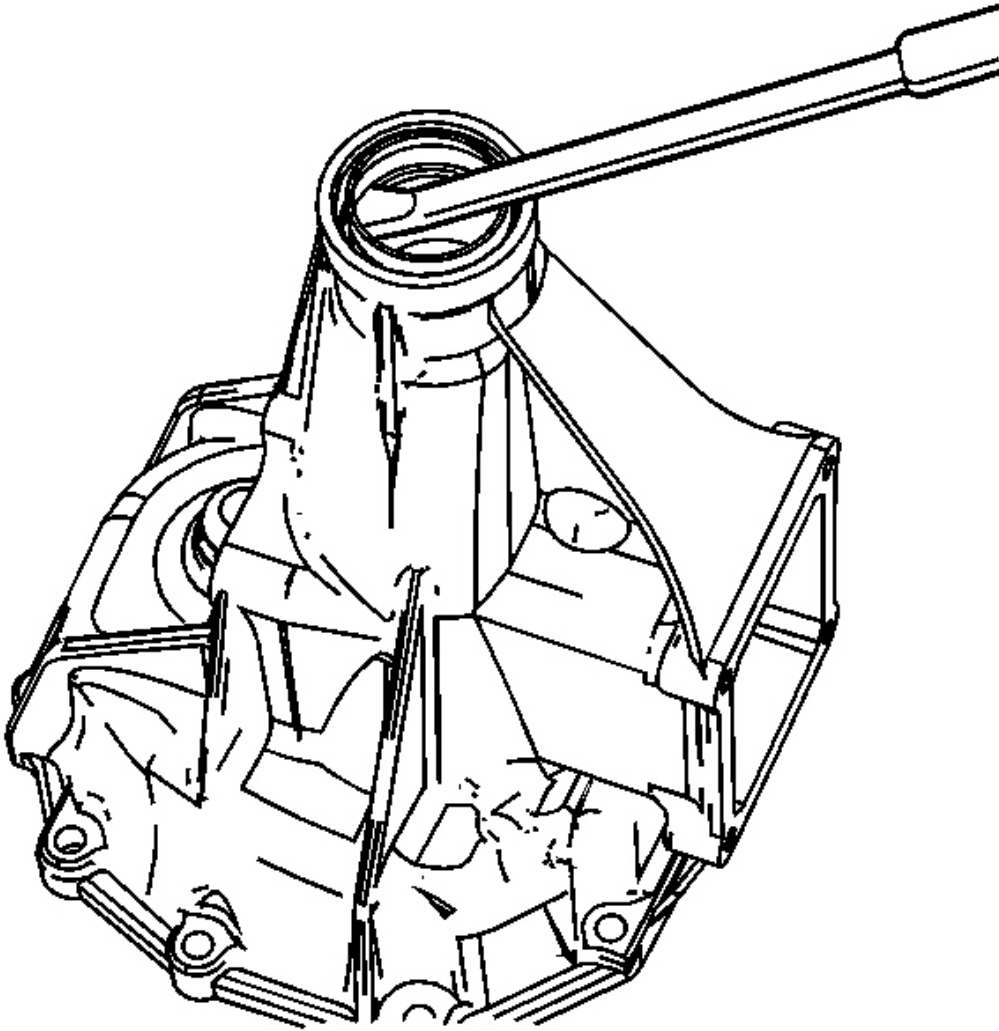

Fig. 120: Removing Output Shaft Seal - RWD
Courtesy of GENERAL MOTORS CORP.

5. For the RWD transmission, using a suitable prying tool, remove the output shaft seal from the extension housing.

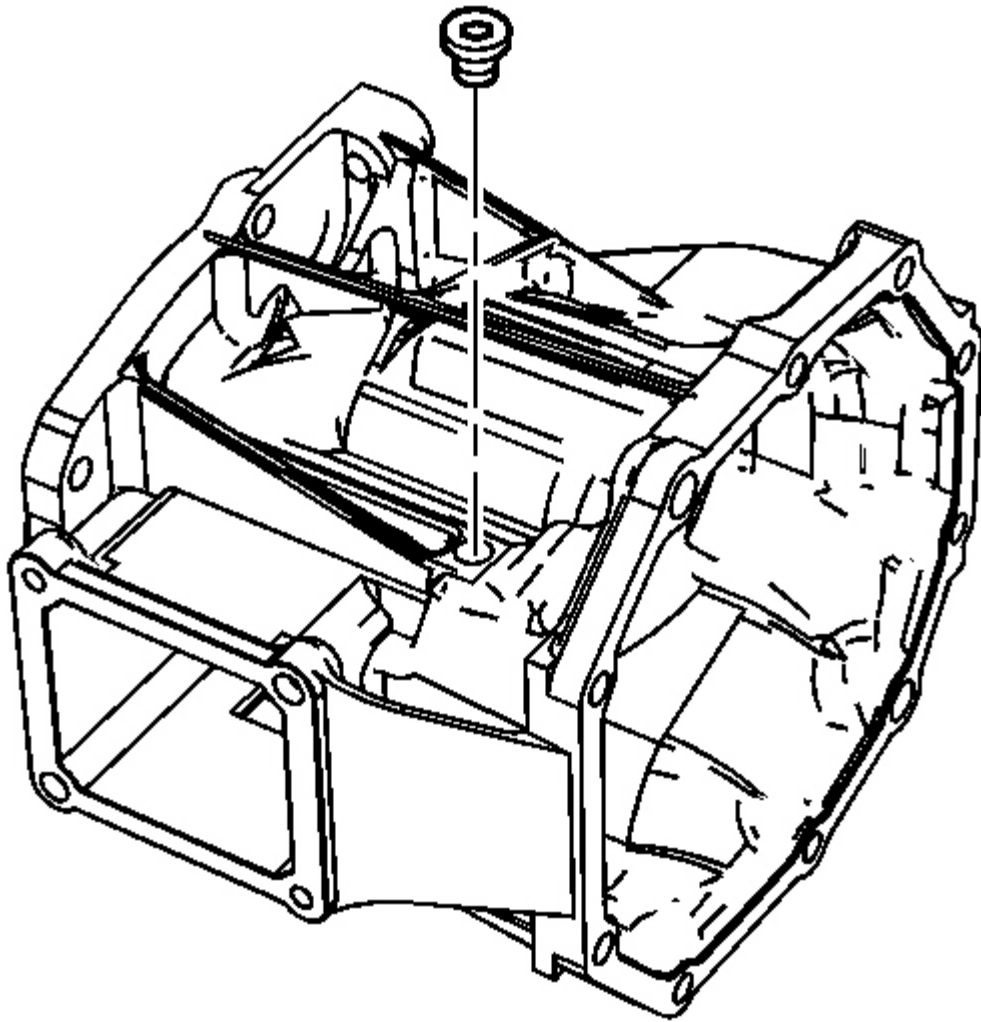

Fig. 121: View Of Reverse Restrictor Pin Plug
Courtesy of GENERAL MOTORS CORP.

6. Remove the reverse control lever restrictor pin plug. Discard the plug. A new plug is required for assembly.

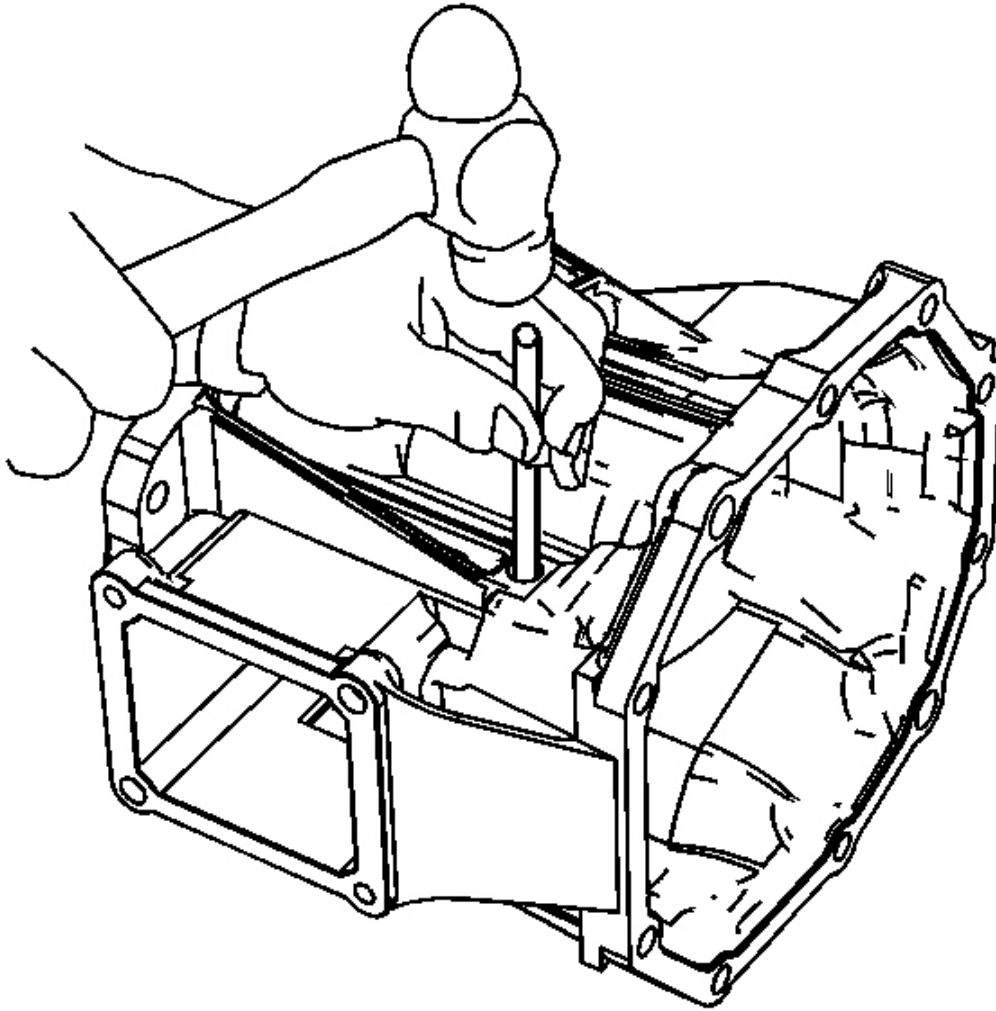

Fig. 122: Removing/Installing Reverse Control Lever Restrictor Roll Pin
Courtesy of GENERAL MOTORS CORP.

7. Remove the roll pin for the reverse control lever restrictor.

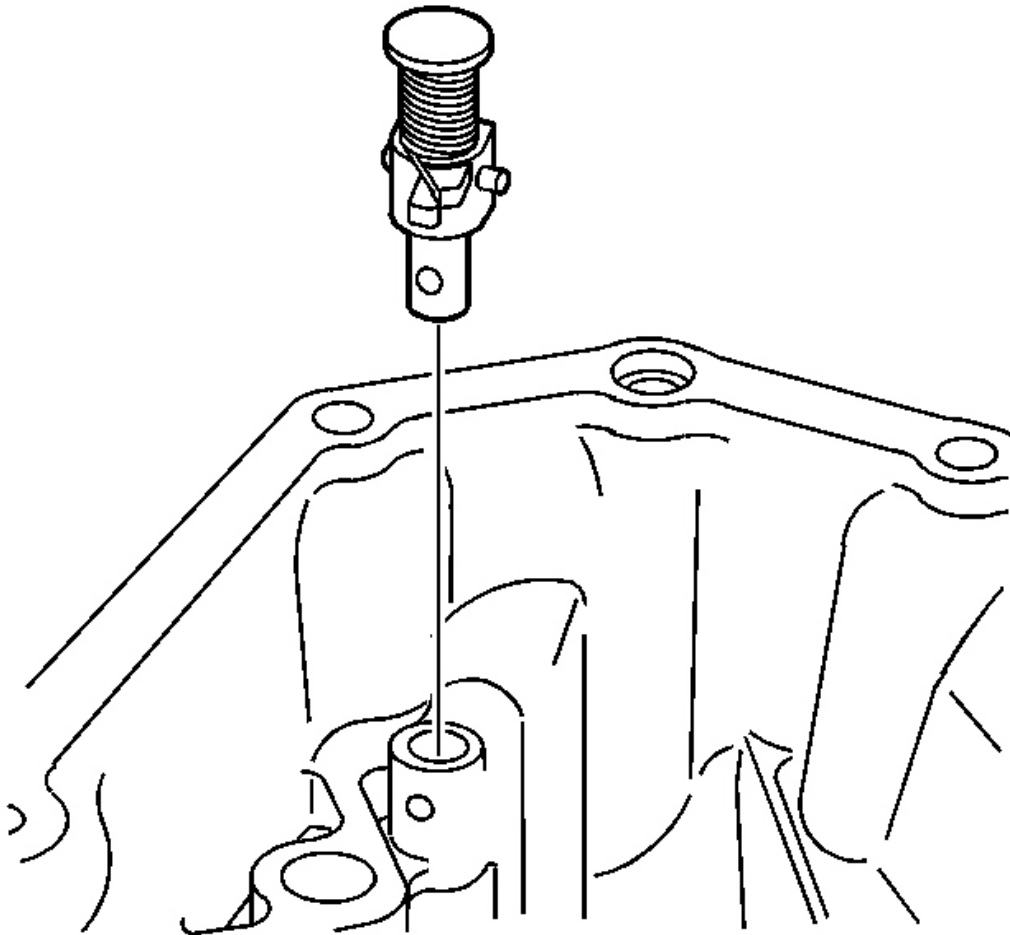

Fig. 123: Locating Reverse Control Lever Restrictor
Courtesy of GENERAL MOTORS CORP.

8. Remove the reverse control lever restrictor.

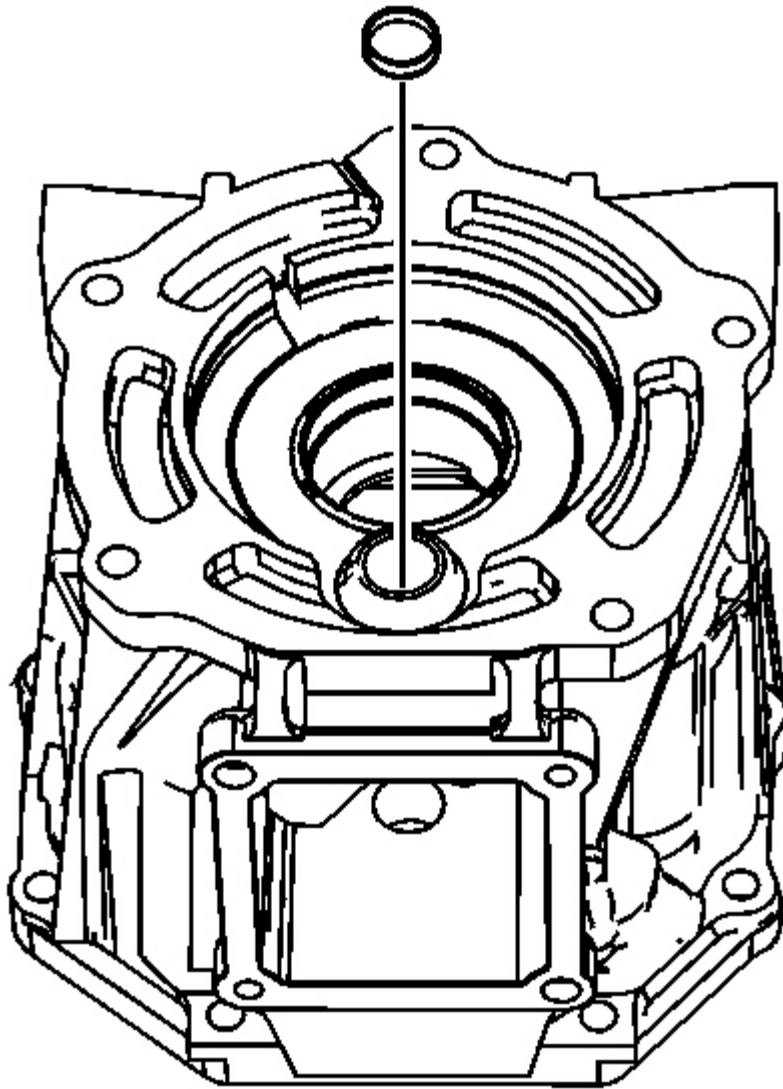

Fig. 124: View Of Shift Control Shaft Plug
Courtesy of GENERAL MOTORS CORP.

9. For the 4WD transmission, remove the shift control shaft plug. Only remove the plug if it is leaking.

1st/2nd Gear Synchronizer

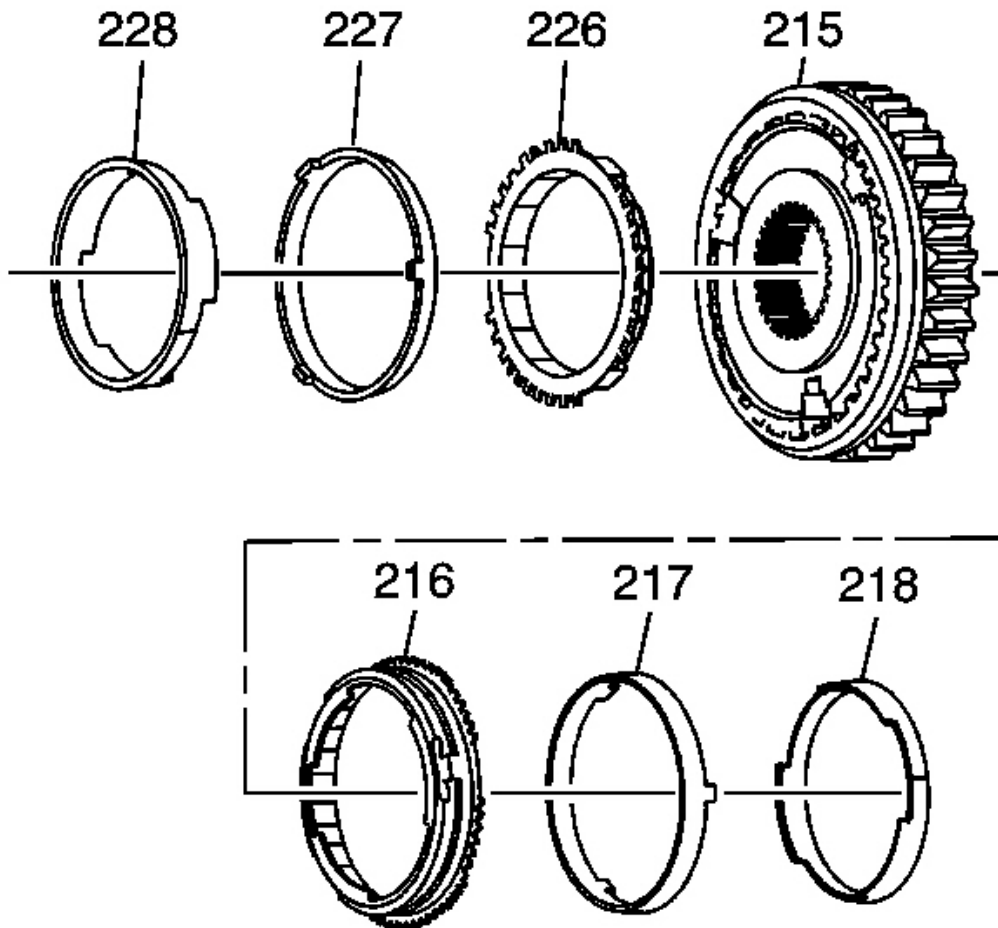

Fig. 125: Identifying 1st/2nd Gear Synchronizer Hub Components
Courtesy of GENERAL MOTORS CORP.

IMPORTANT: When servicing the synchronizers, retain them in the same order that they are removed. Keep the synchronizer components together and mark them to identify correct location.

1. Remove the following components from the 1st/2nd gear synchronizer hub (215):
 - The 2nd gear inner blocking ring (228)

- The 2nd gear internal blocking ring (227)
- The 2nd gear outer blocking ring (226)
- The 1st gear outer blocking ring (216)
- The 1st gear internal blocking ring (217)
- The 1st gear inner blocking ring (218)

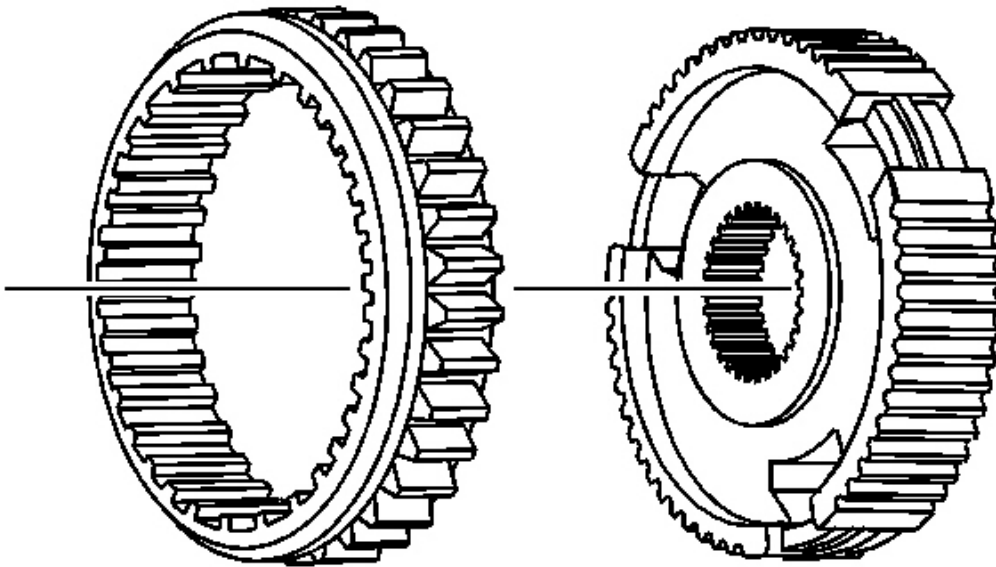

Fig. 126: View Of Reverse Gear & 1st/2nd Gear Synchronizer Hub
Courtesy of GENERAL MOTORS CORP.

2. Remove the reverse gear from the 1st/2nd gear synchronizer hub.

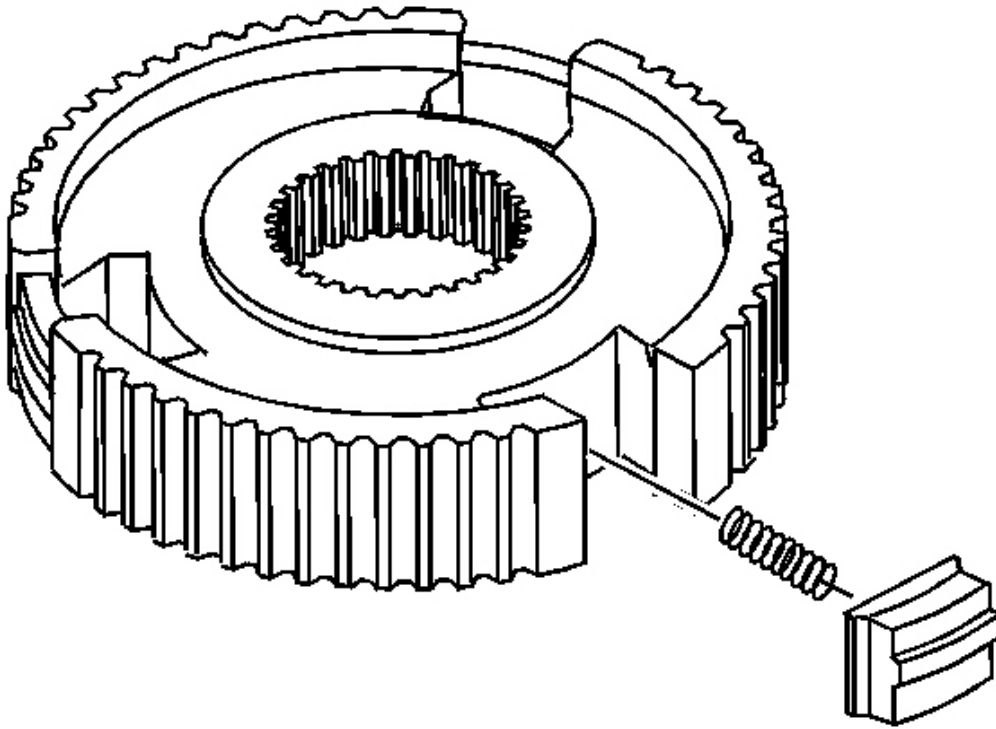

Fig. 127: Locating Synchronizer Insert And Spring
Courtesy of GENERAL MOTORS CORP.

3. Remove the synchronizer insert and spring from the synchronizer hub. Push in on the spring and slide the insert out.

3rd/4th Gear Synchronizer

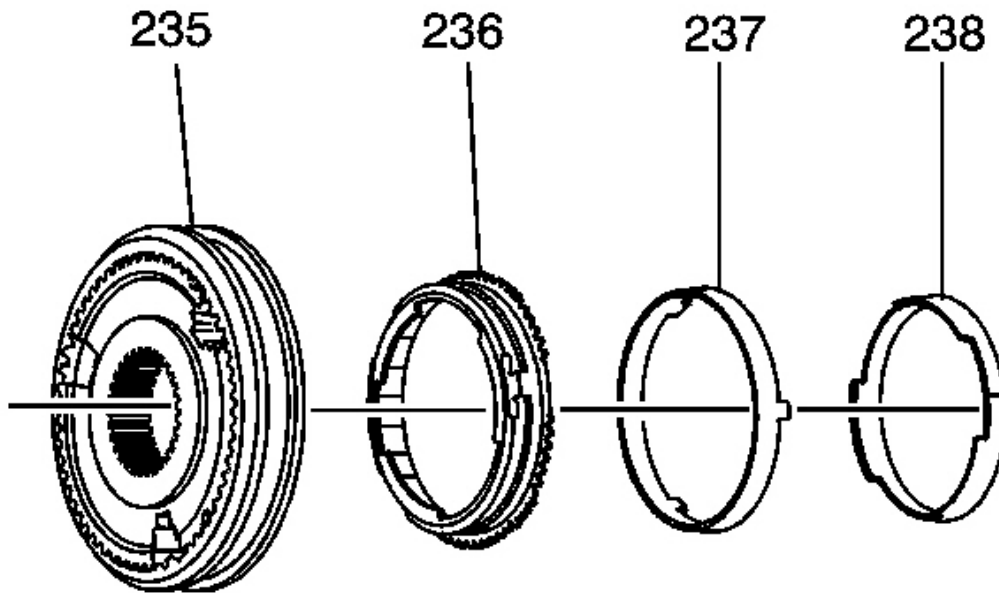

Fig. 128: Locating 3rd/4th Gear Synchronizer Hub Components
Courtesy of GENERAL MOTORS CORP.

1. Remove the following components from the 3rd/4th gear synchronizer hub (235):
 - The 3rd gear outer blocking ring (236)
 - The 3rd gear internal blocking ring (237)
 - The 3rd gear inner blocking ring (238)

The 4th gear blocking ring was removed with the input shaft.

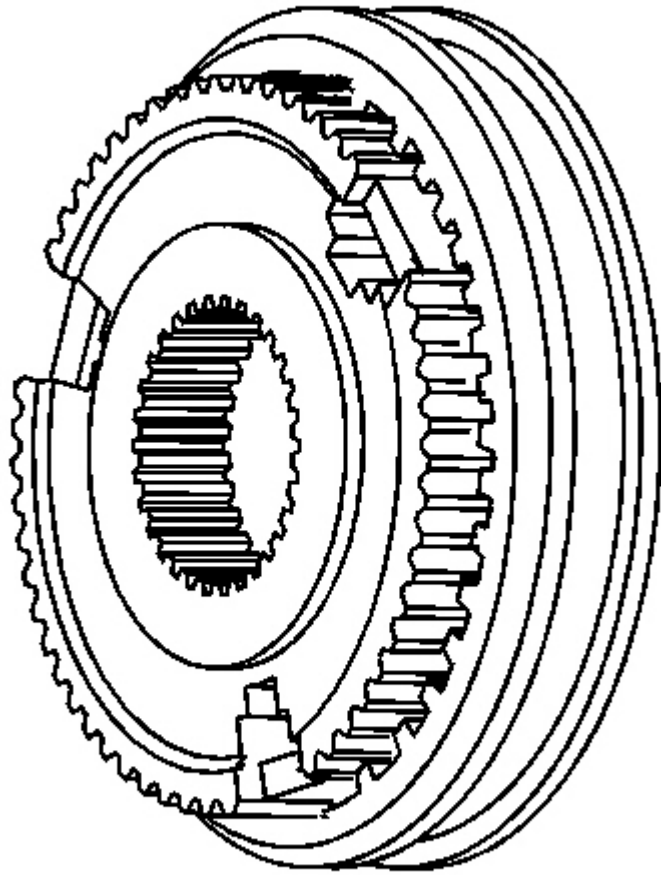

Fig. 129: Identifying 3rd/4th Synchronizer Sleeve
Courtesy of GENERAL MOTORS CORP.

2. Remove the 3rd/4th gear synchronizer sleeve from the 3rd/4th synchronizer hub.

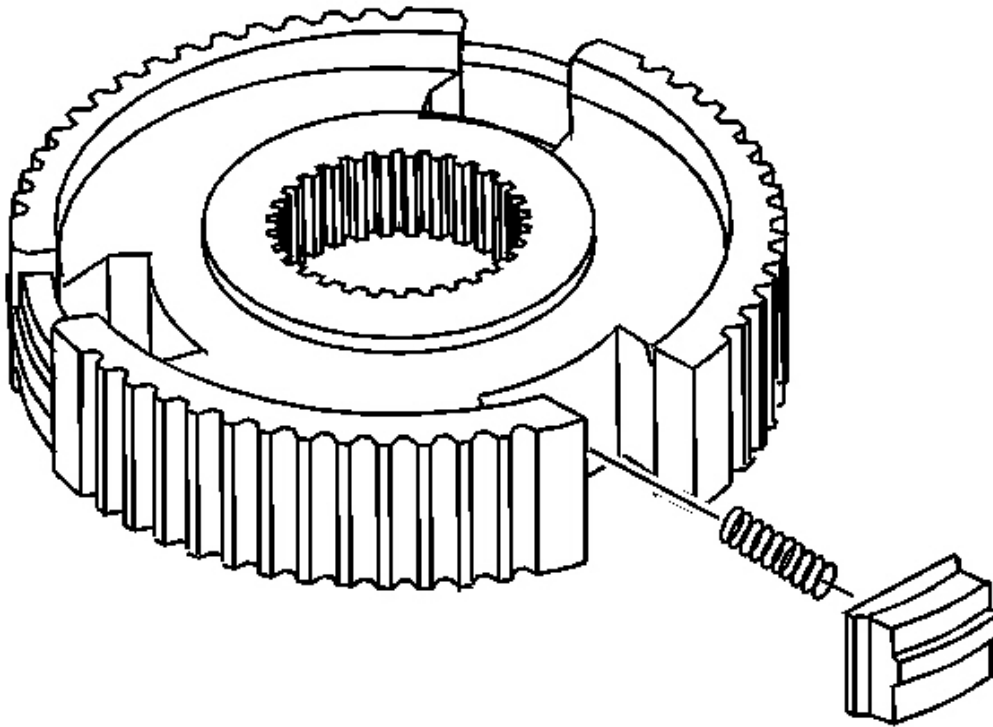

Fig. 130: View Of Synchronizer Insert & Spring
Courtesy of GENERAL MOTORS CORP.

3. Remove the synchronizer insert and spring from the synchronizer hub. Push in on the spring and slide the insert out.

Reverse/5th Gear Synchronizer

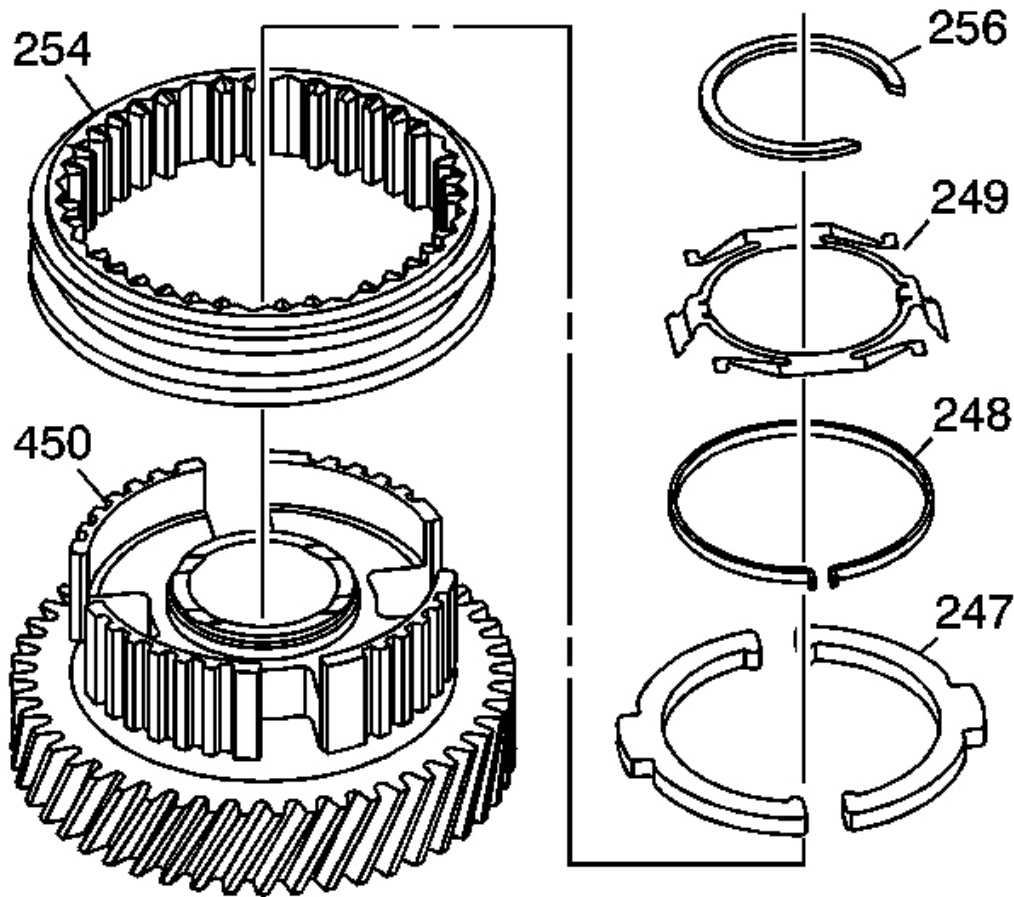

Fig. 131: View Of Reverse/5th Gear Synchronizer Components
Courtesy of GENERAL MOTORS CORP.

Remove the following components from the 5th/reverse countershaft gear (450):

- The 5th/reverse gear synchronizer spring retainer (256)
- The 5th/reverse gear synchronizer spring (249)
- The 5th gear synchronizer spring (248)
- The 5th gear synchronizer insert (247)
- The 5th/reverse synchronizer sleeve (254)

Tools Required

- **J 8001-3** Dial Indicator
- **J 26900-12** Dial Indicator - 1-10 mm. See **Special Tools**.
- **J 26900-13** Magnetic Indicator Base

Output Shaft

Fig. 132: View Of Output Shaft (4WD) & Output Shaft (RWD)
Courtesy of GENERAL MOTORS CORP.

1. Clean the 4WD (195) or the RWD (190) output shaft in a suitable solvent.
2. Clean and air dry the oil gallery.
3. Inspect the output shaft bearing surfaces for the following conditions:
 - Wear
 - Lack of lubricant

- Debris embedded in the oil grooves
 - Brinelling
4. Inspect the output shaft splines for wear or damage.
 5. Replace the output shaft if any of the above conditions are found.

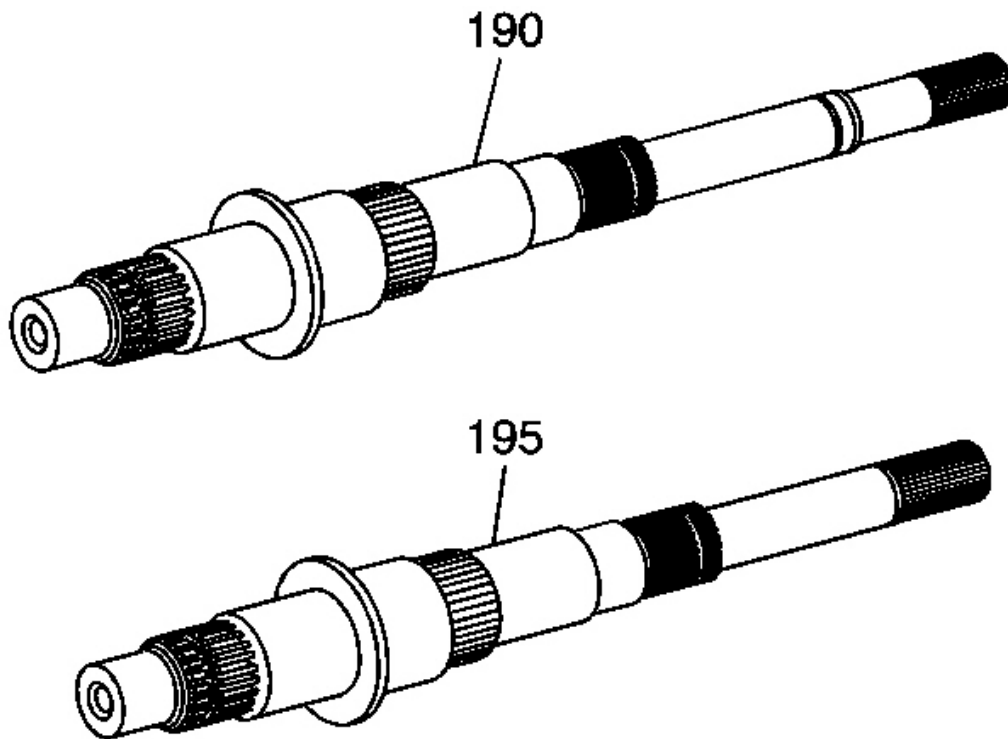
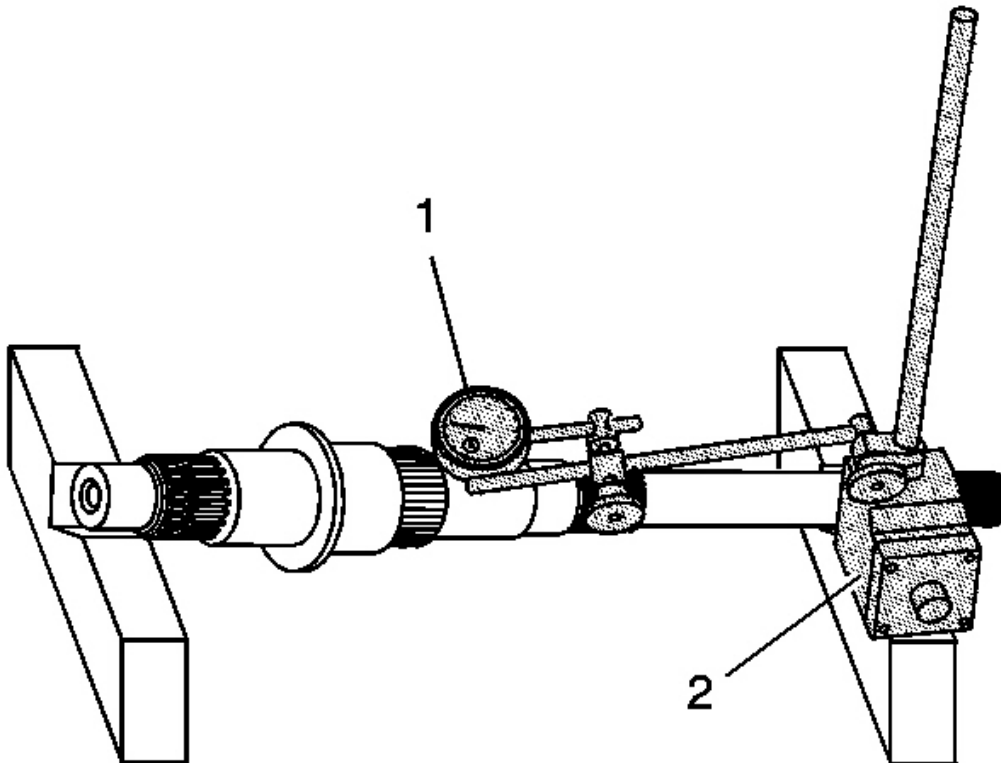

Fig. 133: Checking Output Shaft Runout
Courtesy of GENERAL MOTORS CORP.

6. Using **J 8001-3** or **J 26900-12** (1), **J 26900-13** (2) and V-blocks, inspect the output shaft for runout. See **Special Tools**.

Specification: Maximum runout: 0.06 mm (0.0024 in)

7. If the runout exceeds the maximum, replace the output shaft.

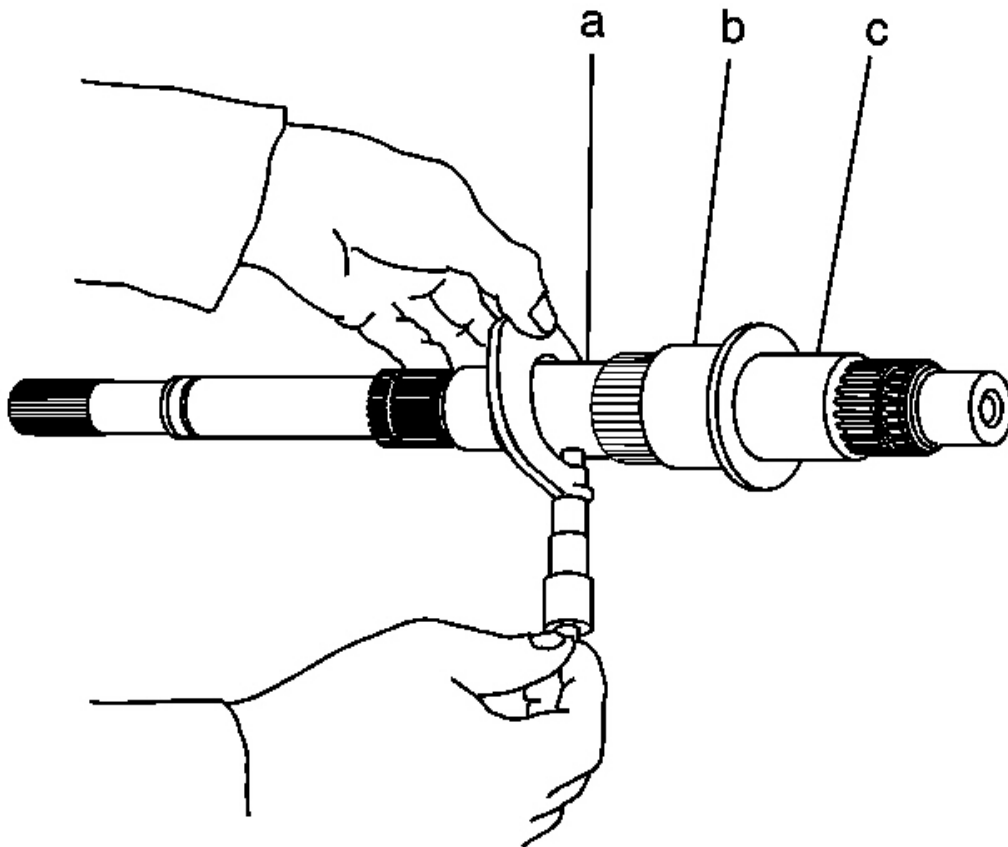

Fig. 134: Measuring Output Shaft Journal Diameter With Micrometer
Courtesy of GENERAL MOTORS CORP.

8. Using a micrometer, measure the diameter of the output shaft journals.

Specification:

- Minimum diameter 1st gear (a): 38.860 mm (1.5299 in)
- Minimum diameter 2nd gear (b): 46.860 mm (1.8449 in)
- Minimum diameter 3rd gear (c): 37.869 mm (1.4905 in)

9. If the journal diameter is less than the minimum, replace the output shaft.

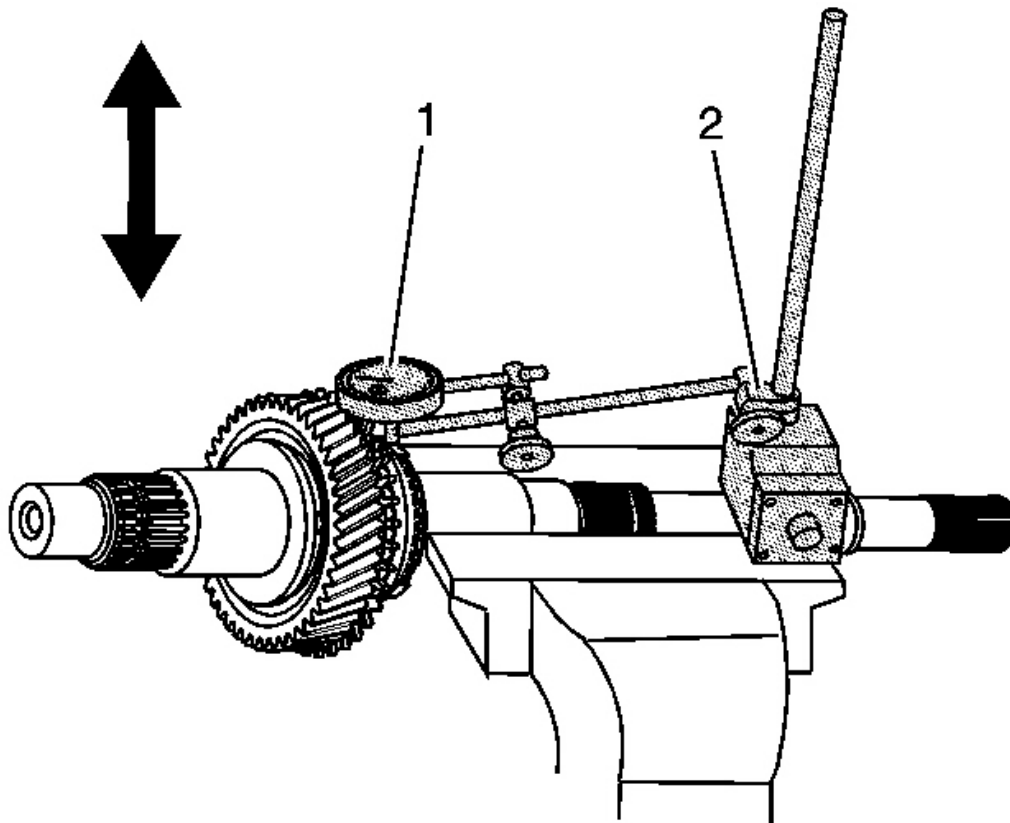

Fig. 135: Checking Radial Clearance Of Speed Gears
Courtesy of GENERAL MOTORS CORP.

10. Measure the radial clearance for each of the speed gears.
 1. Place the speed gear, with the needle roller bearing, on the output shaft at the correct journal.
 2. Use **J 8001-3** or **J 26900-12** (1) and **J 26900-13** (2). See **Special Tools**.
 3. Position **J 8001-3** or **J 26900-12** on the gear. See **Special Tools**.
 4. Move the gear up and down.

Specification:

- Standard Clearance 1st gear: 0.02-0.073 mm (0.0008-0.0029 in)
- Standard Clearance 2nd and 3rd gear: 0.015-0.068 mm (0.0006-0.0027 in)

- Maximum Clearance 1st gear: 0.160 mm (0.0063 in)
- Maximum Clearance 2nd and 3rd gear: 0.160 mm (0.0063 in)

11. If the clearance exceeds the maximum, replace either the gear, the needle roller bearing or the output shaft.

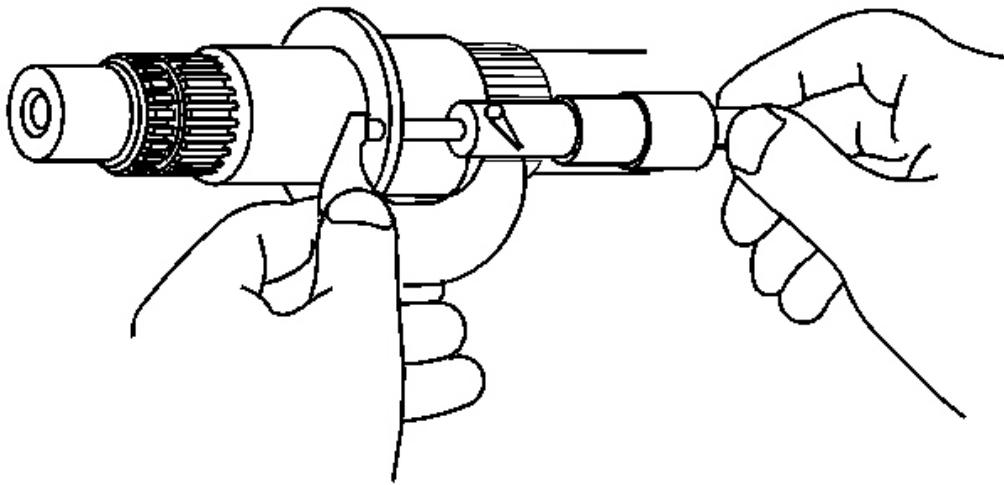

Fig. 136: Measuring Output Shaft Flange Thickness With Micrometer
Courtesy of GENERAL MOTORS CORP.

12. Using a micrometer, measure the output shaft flange thickness.

Specification: Minimum thickness: 4.70 mm (0.1859 in)

13. If the thickness is less than the minimum, replace the output shaft.

Reverse Idler Gear and Shaft

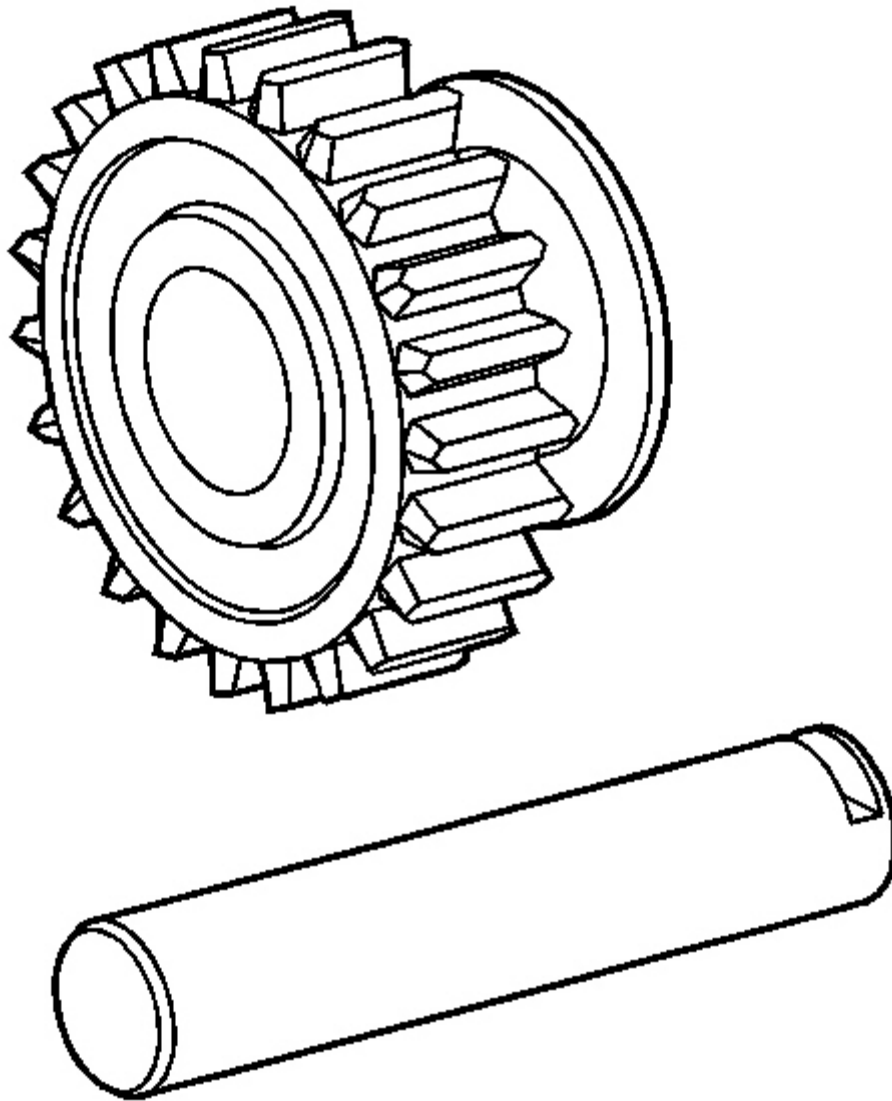

Fig. 137: View Of Reverse Idler Gear & Shaft
Courtesy of GENERAL MOTORS CORP.

1. Clean the reverse idler gear and shaft in a suitable solvent and air dry all the parts.
2. Inspect the bushing in the reverse idler gear for the following conditions:
 - Excessive wear

- Scoring
 - Pitting
3. Replace the reverse idler gear if the bushing is faulty.
 4. Inspect the reverse idler gear shaft for the following conditions:
 - Excessive wear
 - Scoring
 - Pitting
 5. Replace the reverse idler gear shaft if it is faulty.

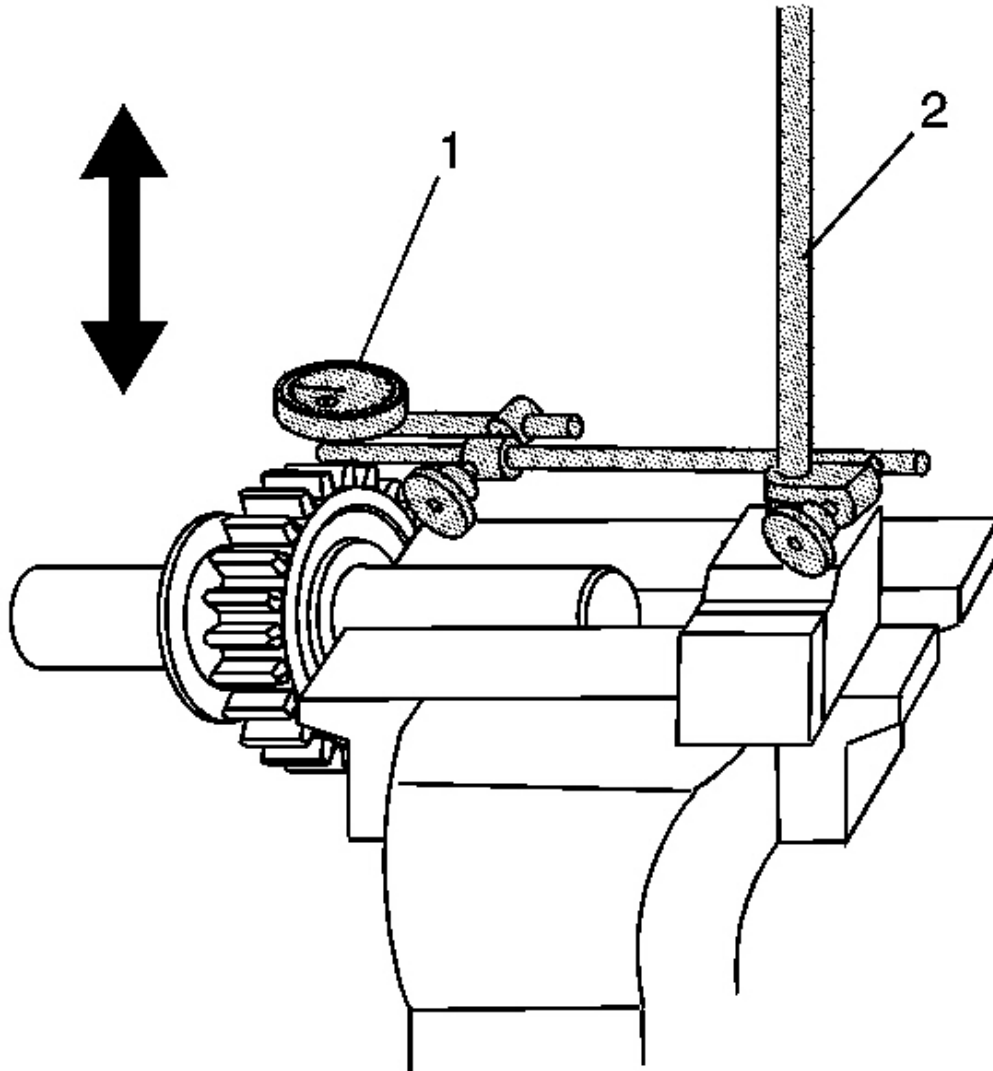

Fig. 138: Checking Reverse Idler Gear Radial Clearance
Courtesy of GENERAL MOTORS CORP.

6. Using J 8001-3 or J 26900-12 (1) and J 26900-13 (2), measure the reverse idler gear radial clearance. See Special Tools.

Specification:

- Standard Clearance: 0.040-0.082 mm (0.0016-0.0032 in)

- Maximum Clearance: 0.130 mm (0.0051 in)
7. If the clearance exceeds the maximum, replace the reverse idler gear or the reverse idler gear shaft.

Countershaft

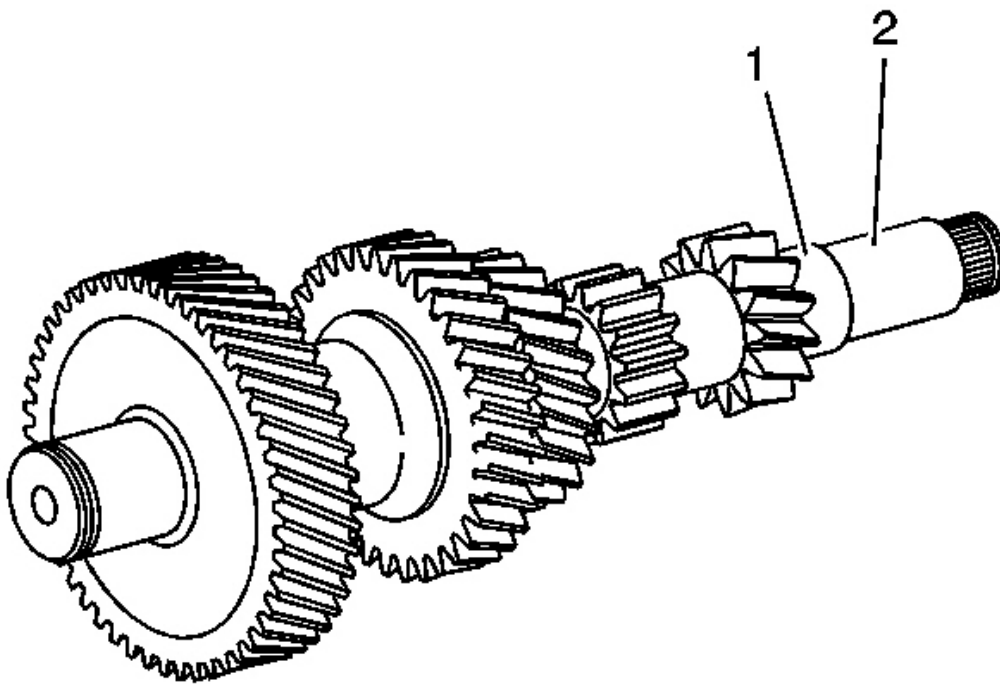

Fig. 139: Inspection Areas On Countershaft
Courtesy of GENERAL MOTORS CORP.

1. Clean the countershaft in a suitable solvent and air dry all the parts.
2. Inspect the rear bearing race (1) on the countershaft for the following conditions:
 - Brinelling
 - Wear
 - Scoring
3. Inspect the 5th countershaft gear bearing race (2) for the following conditions:
 - Brinelling

- Wear
- Scoring

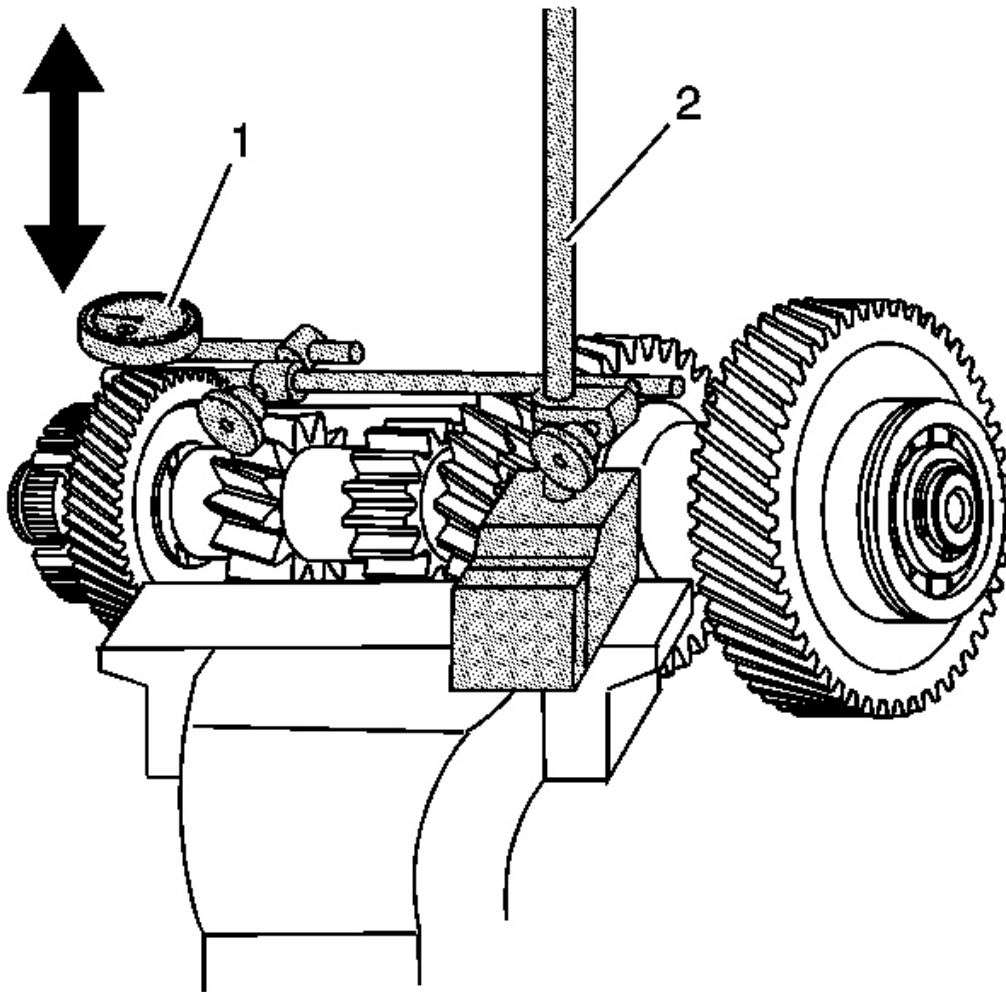

Fig. 140: Checking Radial Clearance For 5th Countershaft Gear
Courtesy of GENERAL MOTORS CORP.

4. Measure the radial clearance for 5th countershaft gear.
 1. Place the 5th countershaft gear, with the needle roller bearing, on the countershaft journal.
 2. Use **J 8001-3** or **J 26900-12 (1)** and **J 26900-13 (2)**. See **Special Tools**.

3. Position **J 8001-3** or **J 26900-12** on the gear. See **Special Tools**.
4. Move the gear up and down.

Specification:

- Standard Clearance: 0.015-0.068 mm (0.0006-0.0027 in)
 - Maximum Clearance: 0.160 mm (0.0063 in)
5. If the clearance exceeds the maximum, replace the gear, the roller bearing or the countershaft.

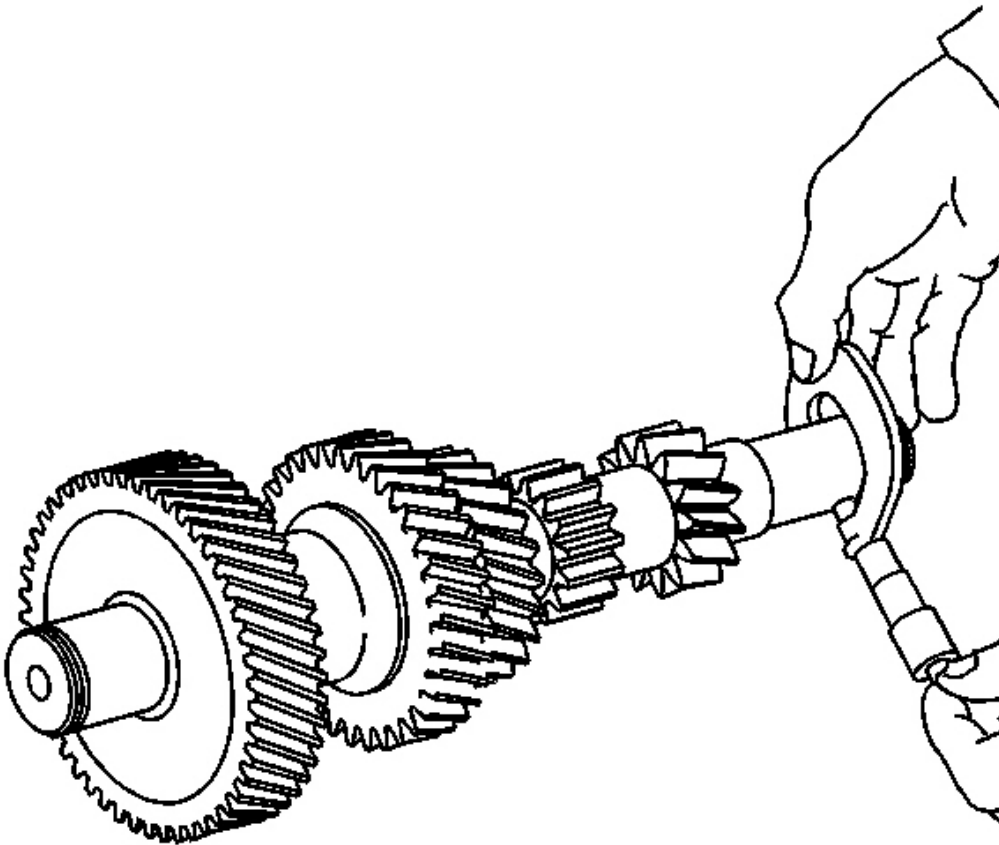

Fig. 141: Measuring Outer Diameter Of Countershaft Journal
Courtesy of GENERAL MOTORS CORP.

- Using a micrometer, measure the outer diameter of the countershaft journal.

Specification: Minimum diameter: 29.860 mm (1.1756 in)

- Inspect all of the countershaft gears for being faulty following the gear inspection steps.
- Replace the countershaft if it is faulty.

Input Shaft

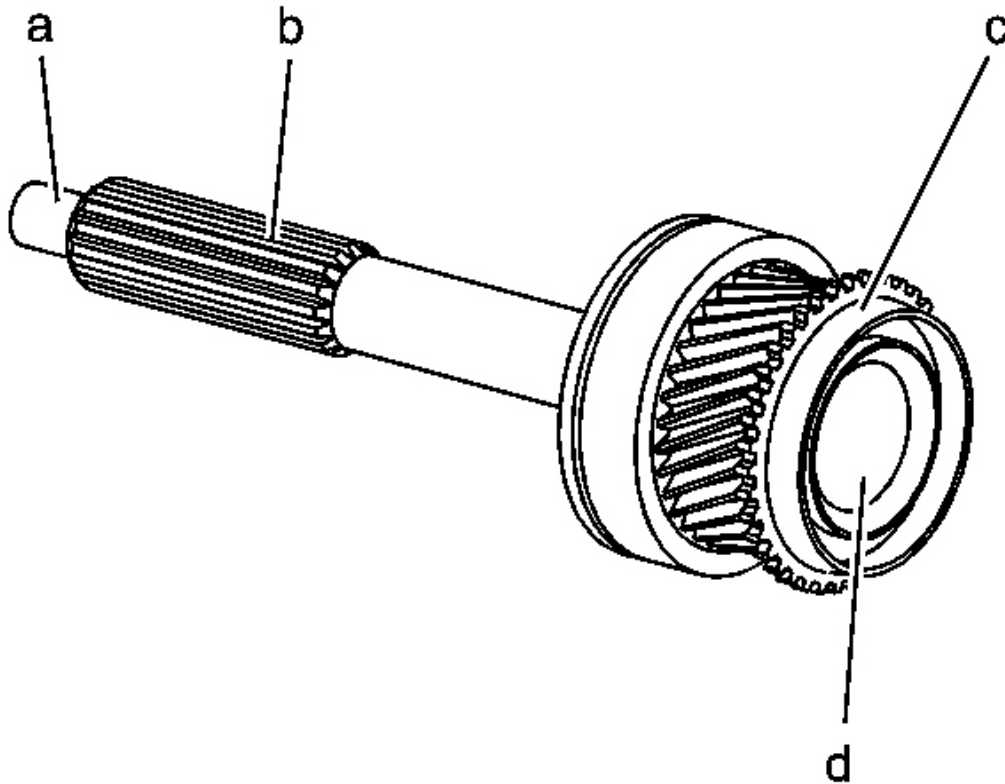

Fig. 142: View Of Input Shaft & Synchronizer Blocking Ring Surface Inspection Areas

Courtesy of GENERAL MOTORS CORP.

- Clean the input shaft in a suitable solvent and air dry all the parts.
- Inspect the pilot bearing journal (a) for wear or scoring.

3. Inspect the clutch disc splines (b) for wear. Steps in the splines may cause concerns with clutch operation.
4. Inspect the synchronizer blocking ring surface (c) for the following conditions:
 - Grooves
 - Excessive wear
 - Heat marks
 - Scoring
5. Inspect the output shaft front support bearing journal (d) for the following conditions:
 - Brinelling
 - Pitting
 - Excessive wear
6. Inspect the gear teeth and selector teeth for being faulty following the gear inspections steps.
7. Replace the input shaft if any of the above conditions are found.

Gears

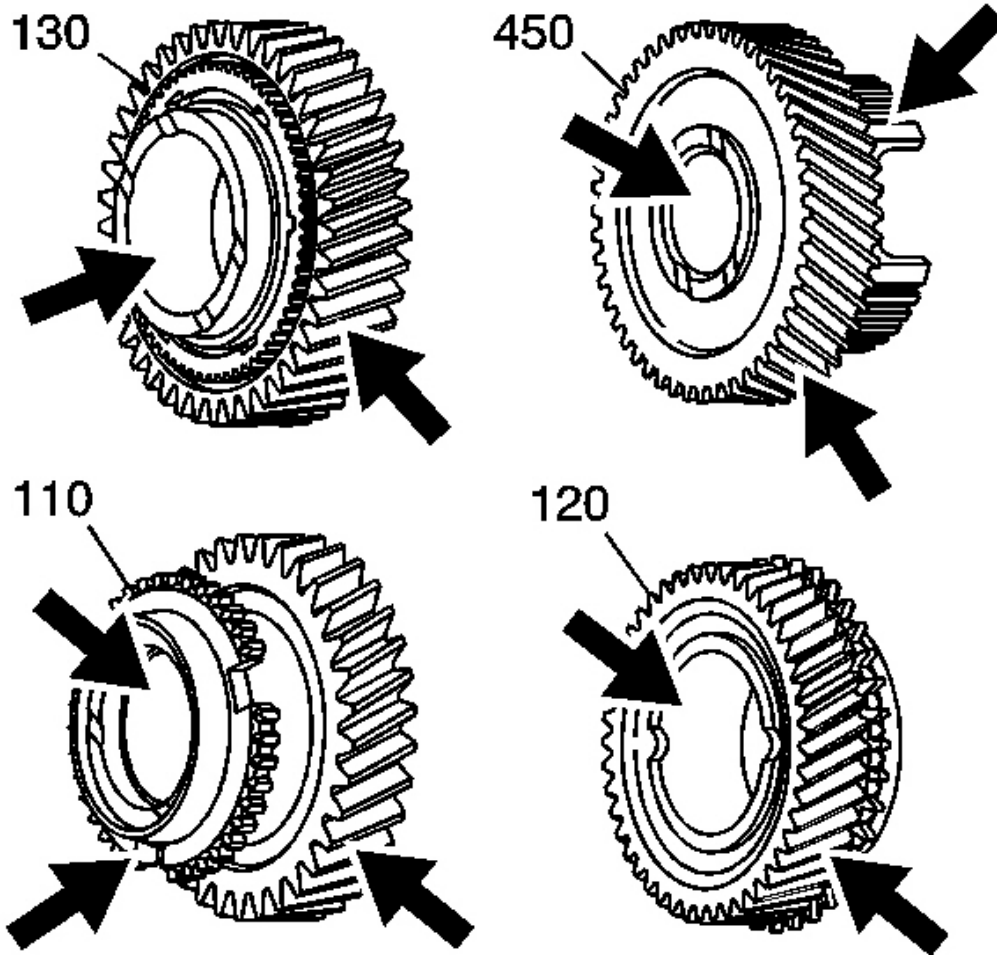

Fig. 143: Identifying Inspection Areas On Gears
Courtesy of GENERAL MOTORS CORP.

1. Clean the 1st gear (110), the 2nd gear (120), the 3rd gear (130) and the 5th countershaft gear (450) in a suitable solvent and air dry all the parts.

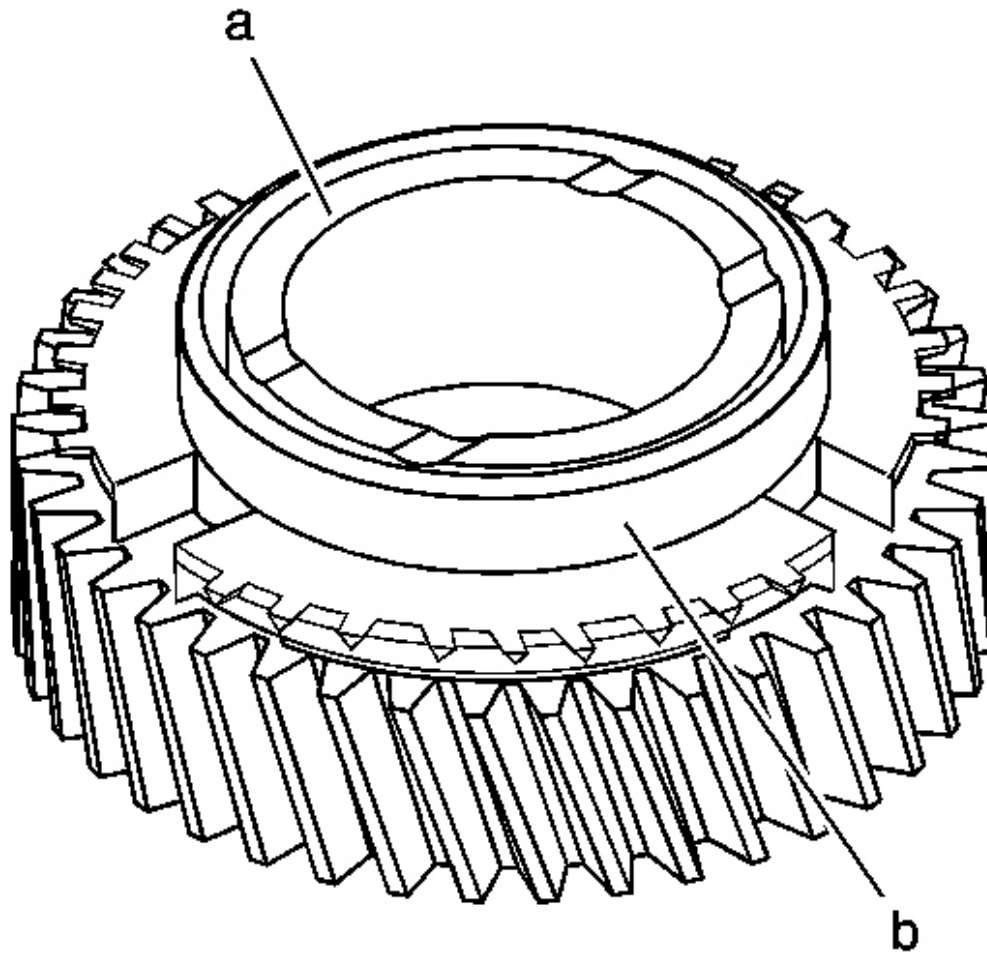

Fig. 144: View Of Inspection Areas On Thrust Surfaces Of Gears
Courtesy of GENERAL MOTORS CORP.

2. Inspect the thrust surfaces (a) on both sides of the gears for the following conditions:
 - Wear
 - Galling
 - Scoring
3. Replace any gears that have faulty thrust surfaces. Worn thrust surfaces may cause gear clashing or hard shifting, by not allowing full engagement of the synchronizer blocking rings. Worn thrust surfaces may also cause gear noise or may cause clunking during

acceleration or deceleration.

4. Inspect the synchronizer blocking ring surface (b) for the following conditions:
 - Grooves
 - Excessive wear
 - Heat marks
 - Scoring
5. Replace any gear that has a faulty blocking ring surface.

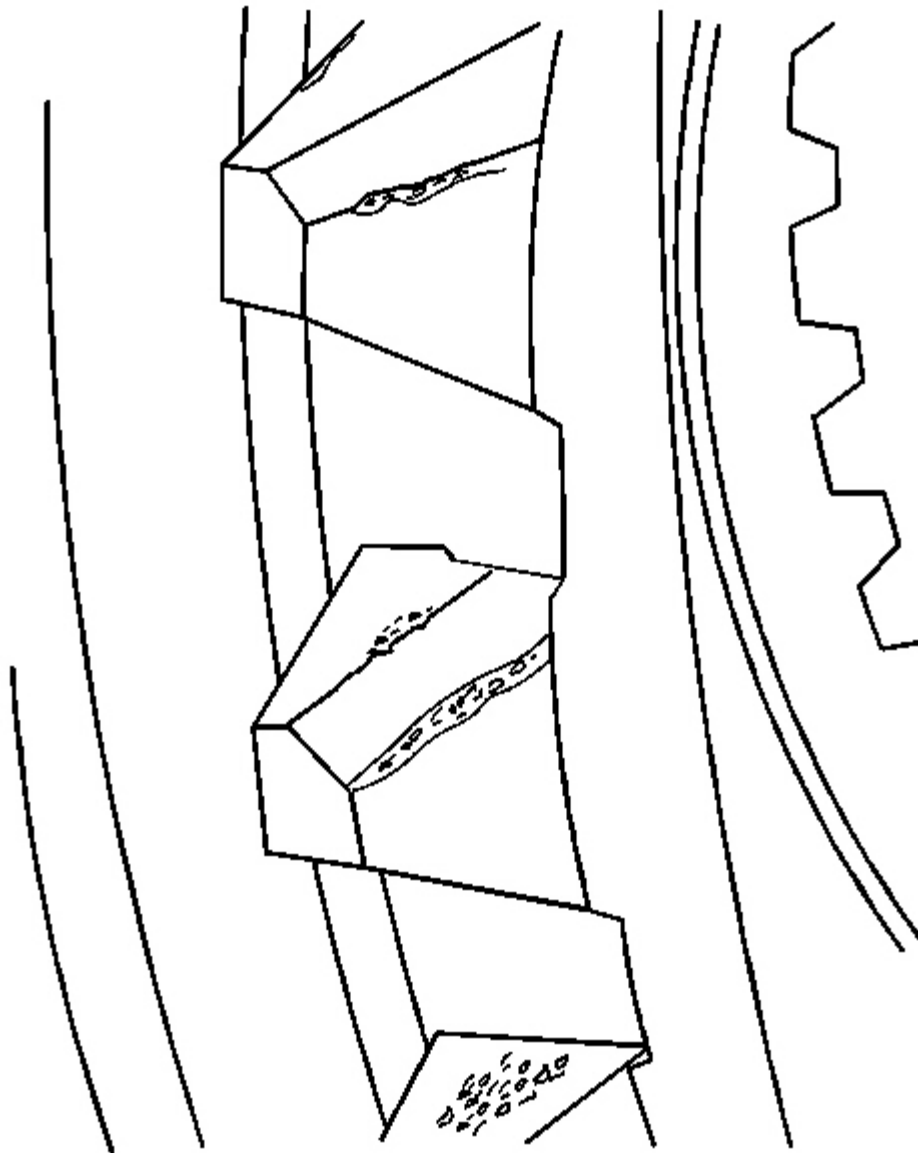

Fig. 145: View Of Gear Change Damage On Selector Teeth
Courtesy of GENERAL MOTORS CORP.

6. Inspect the selector teeth of the gears for gear change damage.

If there is gear change damage, the tooth edges are worn and chipped and, in some cases,

affected by plastic deformation because of high shift loads that resemble ragged edges. Such severe deformation of the selector teeth edges causes hard gearshift changes. The spline flanks may also show signs of wear resembling fretting corrosion.

7. If gear change damage is present, replace or repair the affected parts. Gear change damage is caused by any of the following conditions:
 - Corresponding speeds of gears not adequately matched
 - Operating the transmission incorrectly
 - Incorrect clutch operation

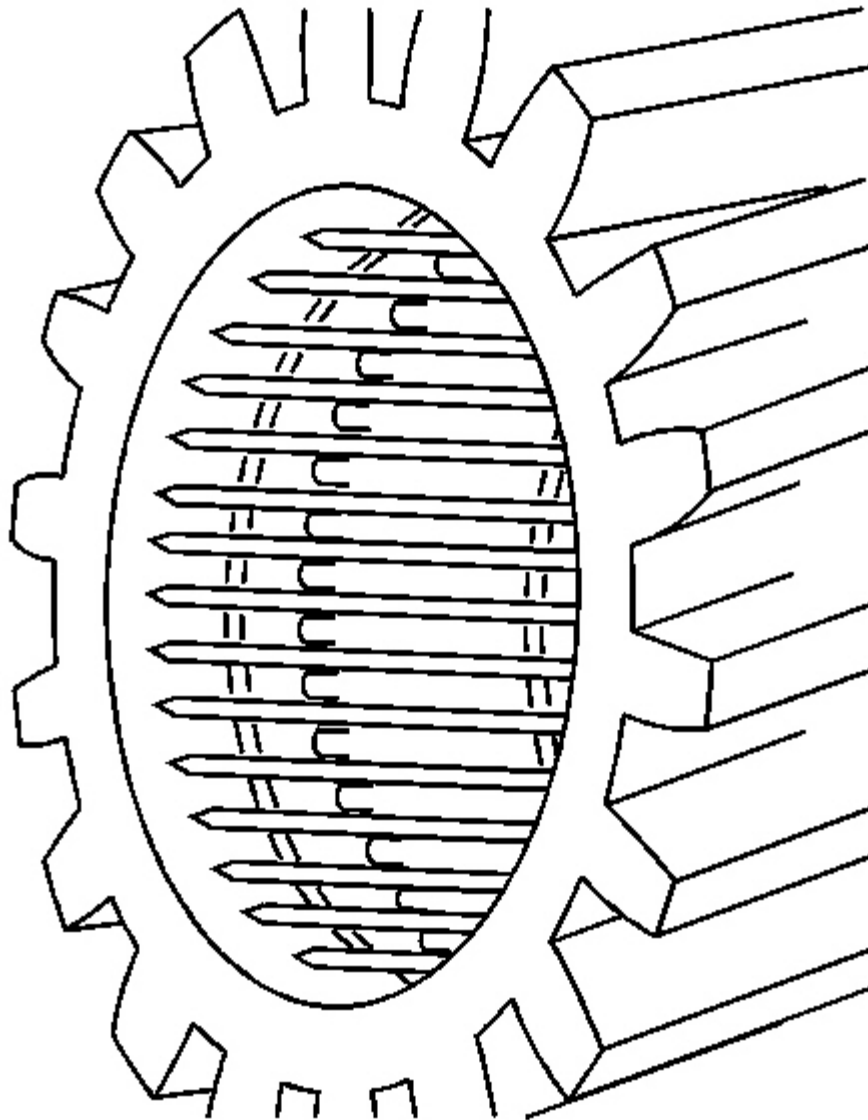

Fig. 146: Brinelling On Roller Races Of Gears
Courtesy of GENERAL MOTORS CORP.

8. Inspect the gears for brinelling.

Brinelling occurs on the roller races of the gears and is characterized by what appears to be the impression of the bearing rollers.

9. Replace any gears showing brinelling.

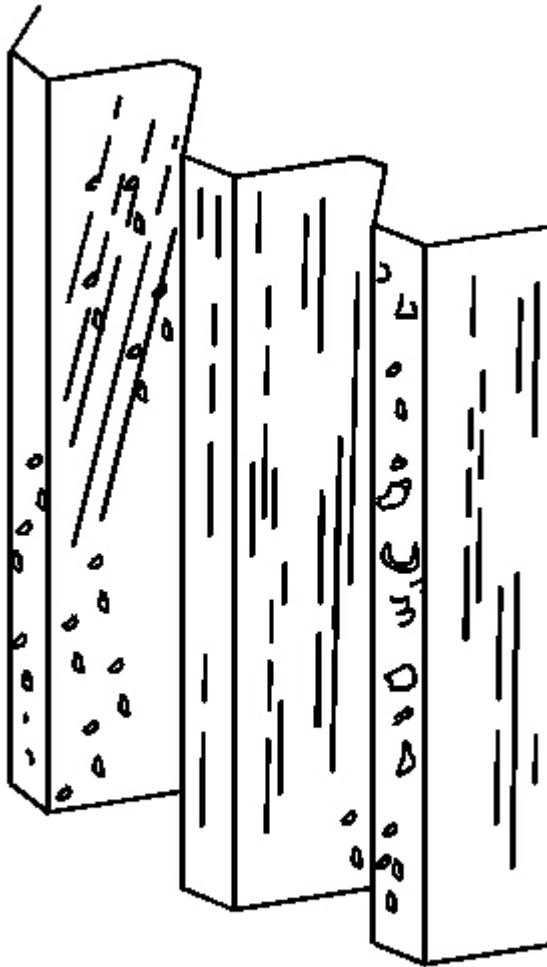

Fig. 147: View Of Break-in-Wear Or Running-In-Wear On Gears
Courtesy of GENERAL MOTORS CORP.

10. Inspect the gears for break-in-wear or running-in-wear.

Break-in-wear is not considered damage because it usually ceases after the running-in-period has expired, without damaging the components. Rough peaks produced during manufacture are worn away or, to some extent, are rolled into the surface. The grinding and

shaving marks on the surface are still visible.

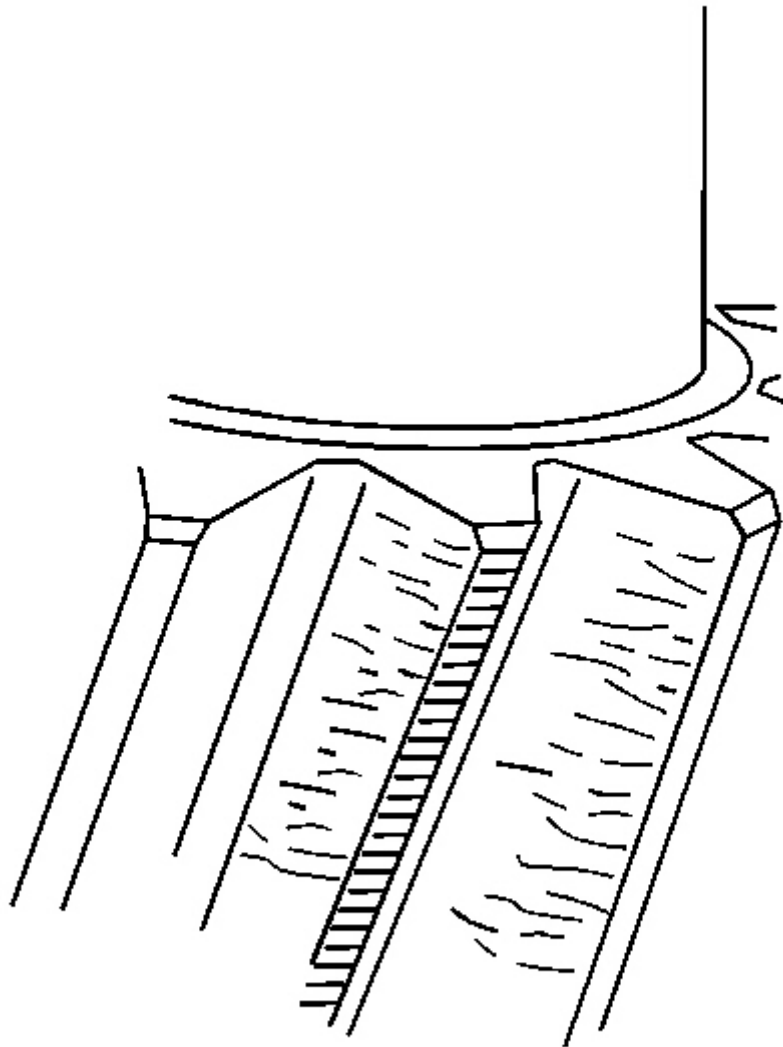

Fig. 148: View Of Scratched Gear Teeth
Courtesy of GENERAL MOTORS CORP.

11. Inspect the gear teeth for scratches.

Scratches are linear indentations on the flank, running in the direction of sliding.

12. If scratches are present, replace the affected parts.

Scratches can be caused by the following conditions:

- Dust and abrasive particles, including those caused by flank contact, in the lubricating oil
- The sliding action of the flanks

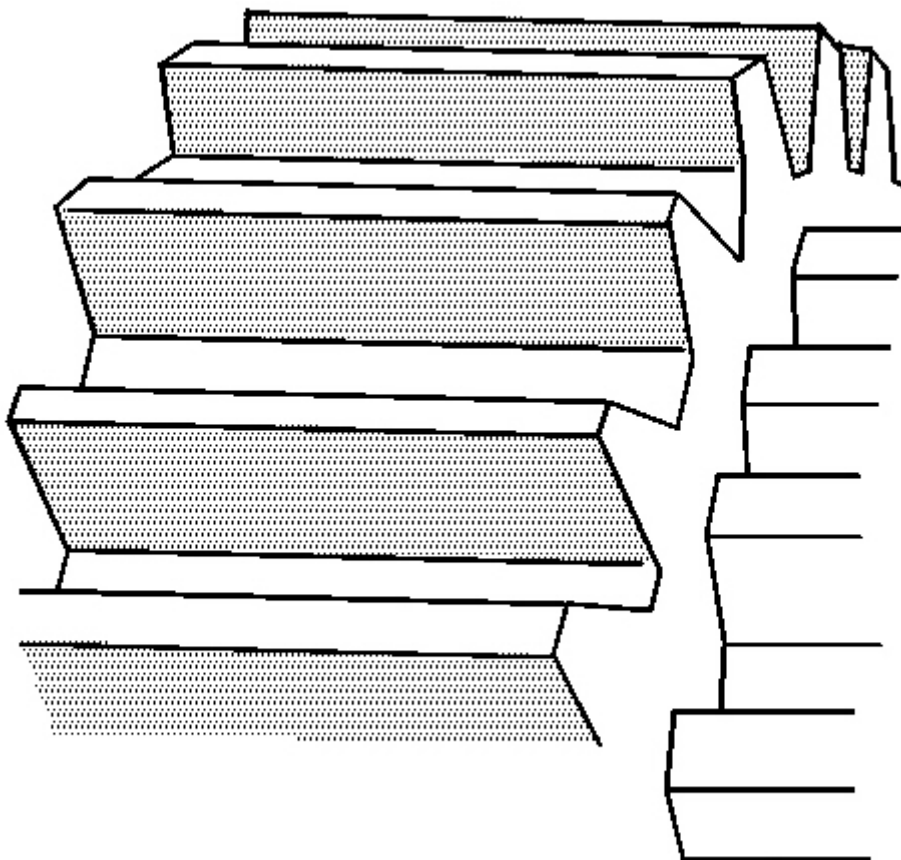

Fig. 149: Abrasive Wear On Gear Teeth
Courtesy of GENERAL MOTORS CORP.

13. Inspect the gear teeth for abrasive wear.

The marks left by the machining process are erased from the active flank. Instead, the entire flank takes on a matte gray appearance. Substantial changes take place in the tooth profile and clearance once abrasive wear has reached an advanced stage. This not only increases the noise level, but can also cause secondary damage.

14. If abrasive wear is present, replace the affected parts.

Abrasive wear is caused by the following conditions:

- Oil contamination resulting from wear or surface fatigue in other areas of the transmission
- Sand, sludge, etc. penetrating into the transmission from the outside

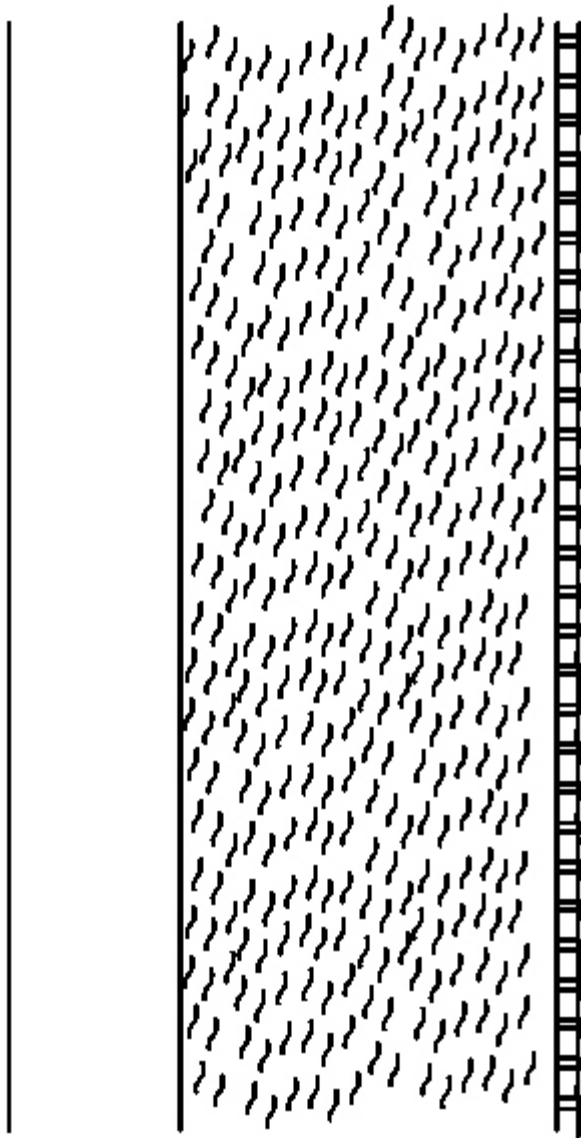

Fig. 150: View Of Rippling Or Brinelling On Gear Teeth
Courtesy of GENERAL MOTORS CORP.

15. Inspect the gear teeth for rippling or brinelling.

The polished tooth flanks show signs of ripple-like alterations in the surface structure, which

run perpendicular to the direction of sliding and may resemble a washboard.

16. If rippling or brinelling is present, replace the affected parts.

Rippling or brinelling is caused by the following conditions:

- A combination of inadequate lubrication, high flank loads and low peripheral speeds
- Friction-induced vibration

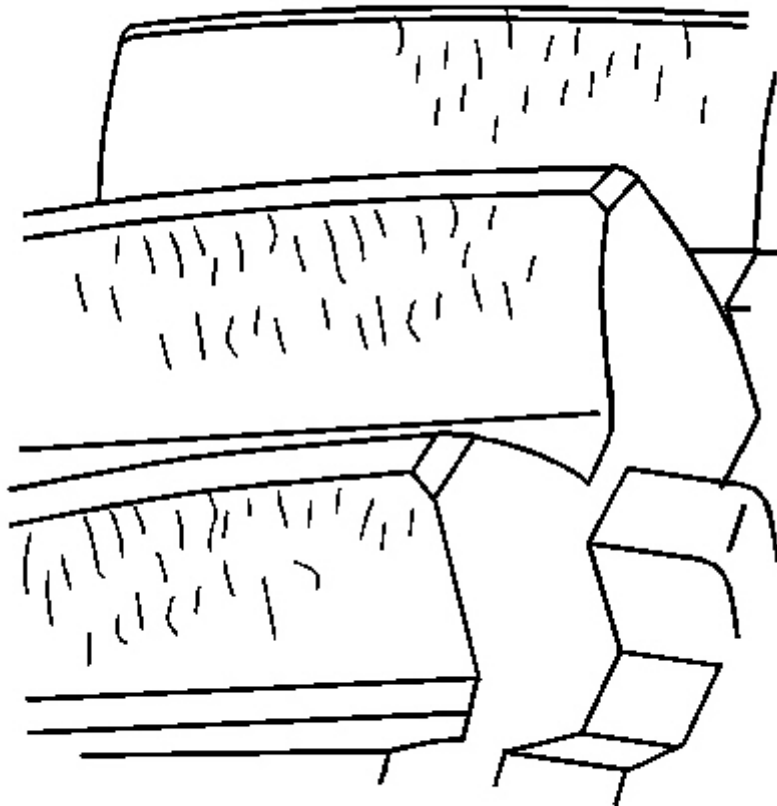

Fig. 151: Light Scoring On Gear Teeth
Courtesy of GENERAL MOTORS CORP.

17. Inspect the gear teeth for light scoring.

Light scoring is identified as rough, partially porous lines or areas aligned in the direction of sliding. When the film of lubricant is torn away between the flanks, this permits direct metal-to-metal contact causing seizure or welding. These welded zones are immediately torn apart again, producing the damage associated with scoring. Scoring initially occurs in areas subjected to high hertz frequency stresses and high sliding speeds, usually along the tooth root and tooth tip. Light scoring only covers a part of the entire surface of the flank or is not strongly developed and has caused only insignificant wear after smoothing.

18. If light scoring is present, replace the affected parts.

Light scoring is caused by the following conditions:

- Inadequate oil viscosity
- Unfavorable gear geometry
- Temporary lack of lubricant
- Surface roughness
- Faulty heat treatment of the gears

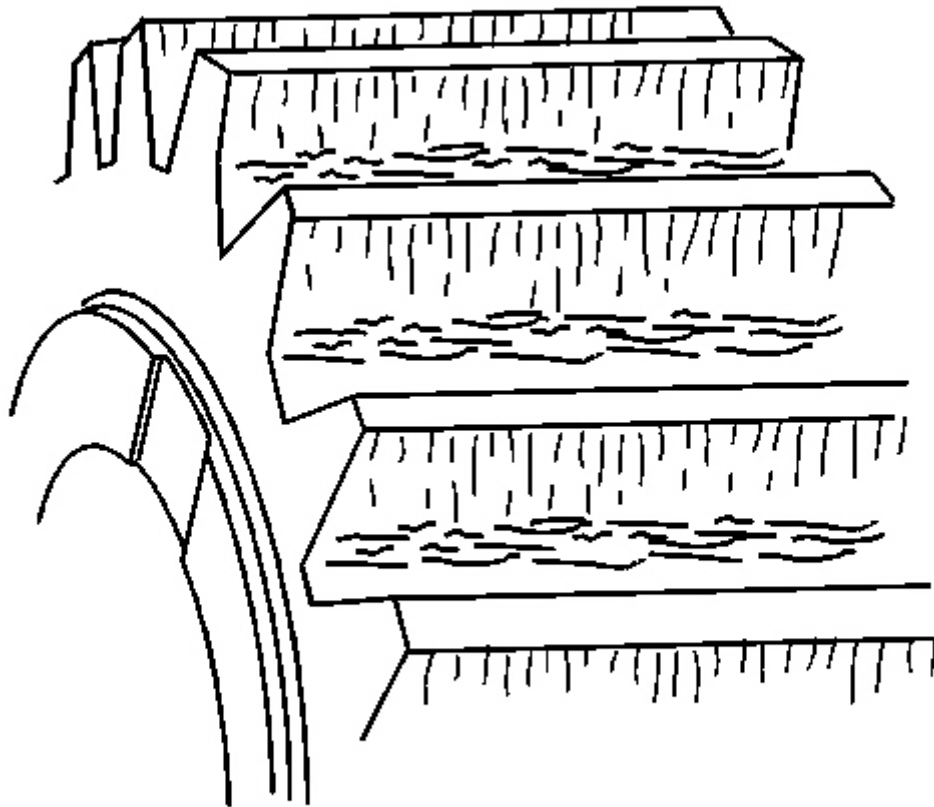

Fig. 152: Severe Scoring On Gear Teeth
Courtesy of GENERAL MOTORS CORP.

19. Inspect the gear teeth for severe scoring.

Severe scoring is the same as light scoring, except large areas of the tooth flank are affected. At an advanced stage, the flank may heat up to such an extent that localized discoloring occurs.

20. If severe scoring is present, replace the affected parts.

Severe scoring is caused by the following conditions:

- Inadequate oil viscosity

- Unfavorable gear geometry
- Temporary lack of lubricant
- Surface roughness
- Faulty heat treatment of the gears

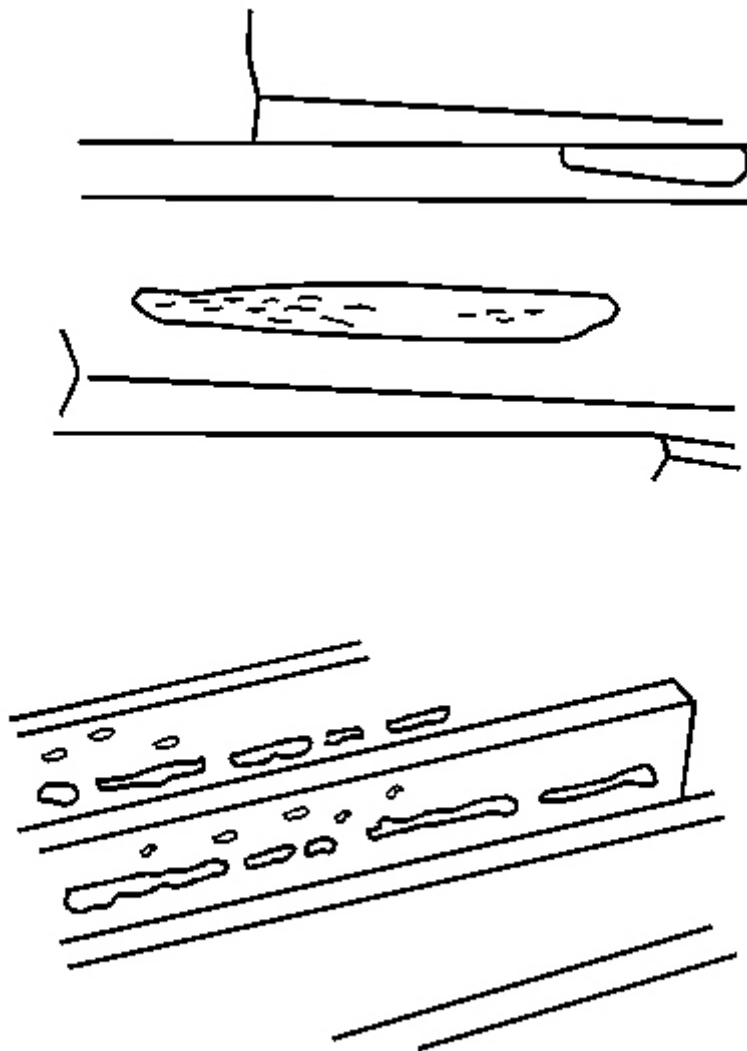

Fig. 153: View Of Flank Fatigue On Gears
Courtesy of GENERAL MOTORS CORP.

21. Inspect the gears for flank fatigue, causing gray spots.

Gray spots are localized pittings on the flank caused by material fatigue and extremely fine pittings formed on the load-bearing flanks. If they are in cluster, they appear to the naked eye as matte gray staining. Under high magnification, a large number of microscopic cracks become visible on the flank. Pittings originating from these cracks may create the appearance of local flank wear. Most of the gray spots are located in the root zone of the gear teeth.

22. If gray spots are present, replace the affected parts.

Gray spots are caused by the following conditions:

- Material fatigue
- Contact pressure
- Sliding movement
- Composite friction

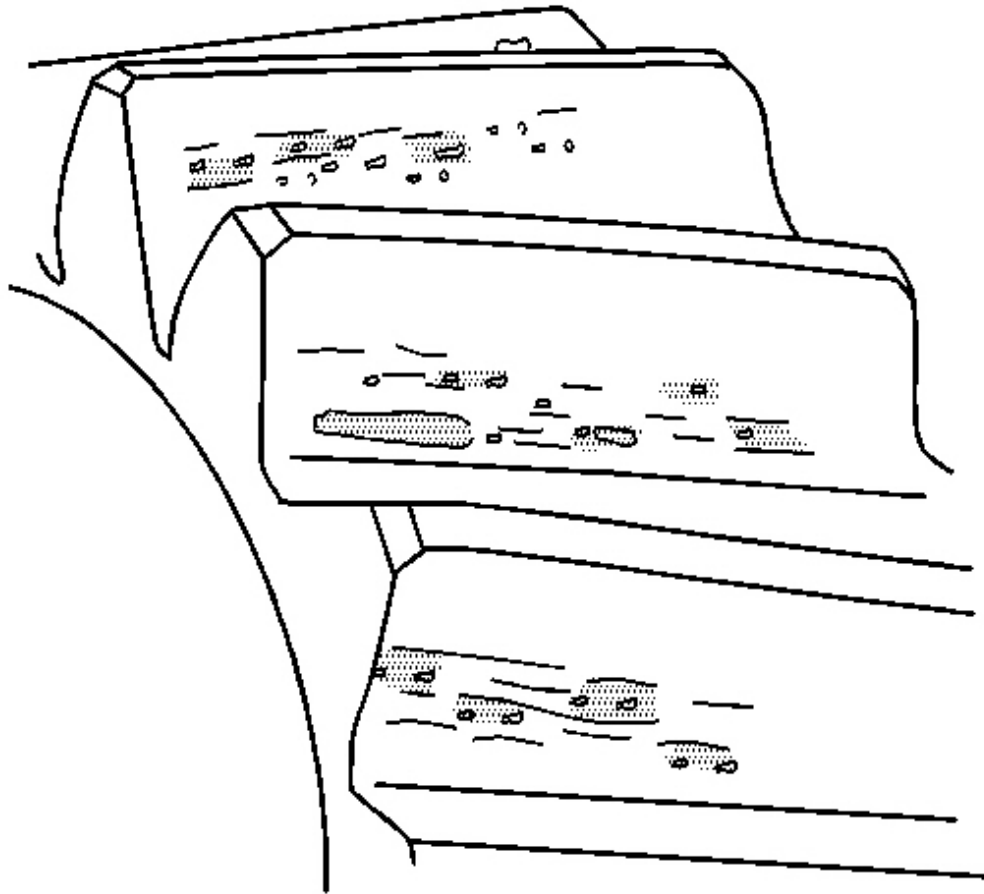

Fig. 154: Identifying Slight Pitting On Gear Teeth
Courtesy of GENERAL MOTORS CORP.

23. Inspect the gear teeth for slight pittings.

Slight pittings are identified as pore-like areas of individual pittings on the flank caused by material fatigue. Usually, slight pittings are only present in the root zone of the flank. Slight pittings may cease after run-in. A change in operating conditions may also stop continued development of slight pitting.

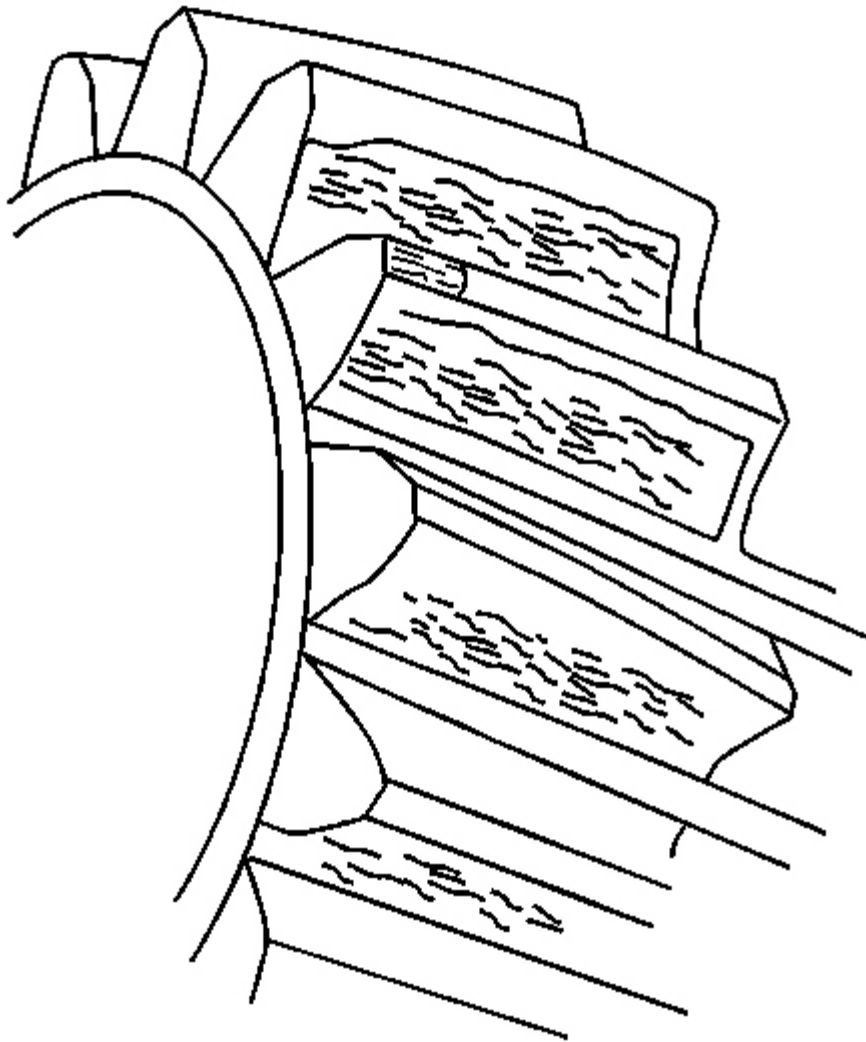

Fig. 155: Identifying Pitted Gear Teeth
Courtesy of GENERAL MOTORS CORP.

24. Inspect the gear teeth for pittings.

Pittings are material fatigue on the flank. The total pitting surface may become so large that smooth running is considerably impaired or the remaining flank face still bearing the load will soon be destroyed by wear.

25. If pittings are present, replace the affected parts.

Pitting is caused by the following conditions:

- Exceeding the sliding and rolling stresses for the material
- Incorrect oil viscosity
- Excessive operating temperature

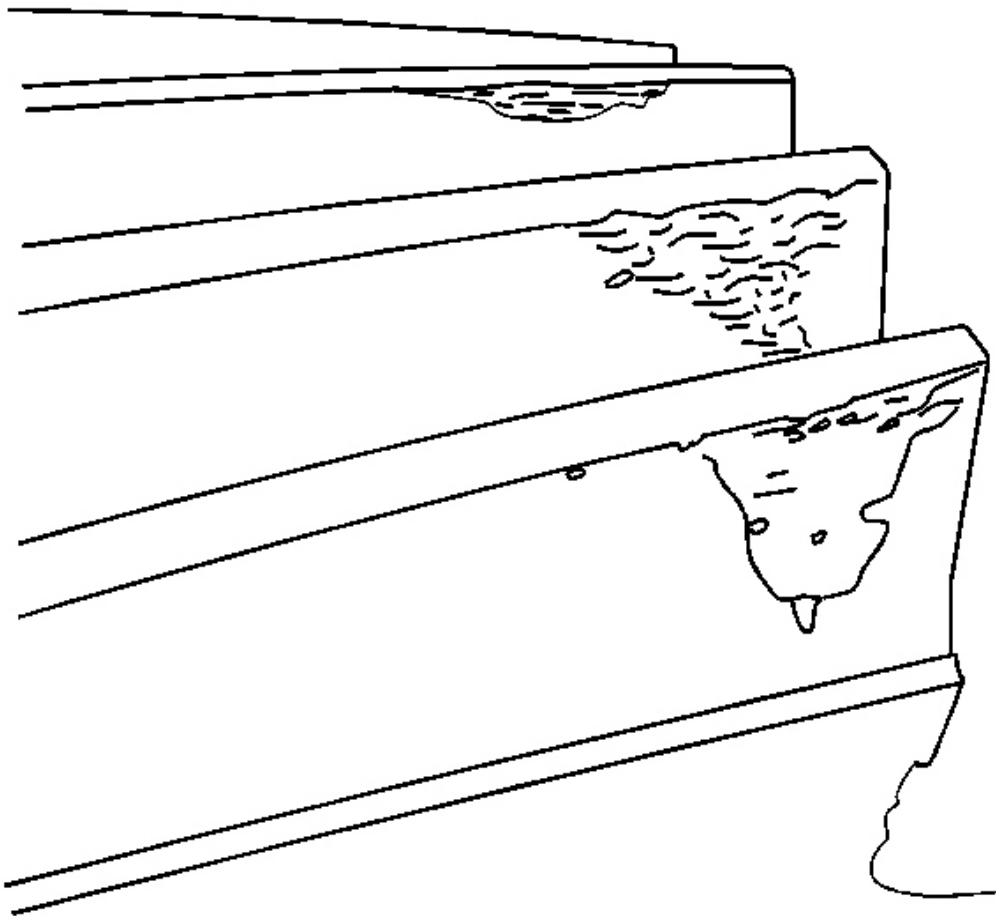

Fig. 156: Identifying Spalling On Gears
Courtesy of GENERAL MOTORS CORP.

26. Inspect the gears for spalling.

Spalling is extensive triangular pits on the flank, spreading from a zone of gray spots or a fine line of pits at the root. The depth of the exposed surface is relatively constant throughout. Further cracks may extend from the pits at an angle. In some cases, the damage may even progress into the tip zone, causing tip damage.

27. If spalling is present, replace the affected parts.

Spalling is caused by the following conditions:

- Exceeding the sliding and rolling stresses for the material
- Incorrect oil viscosity
- Excessive operating temperature

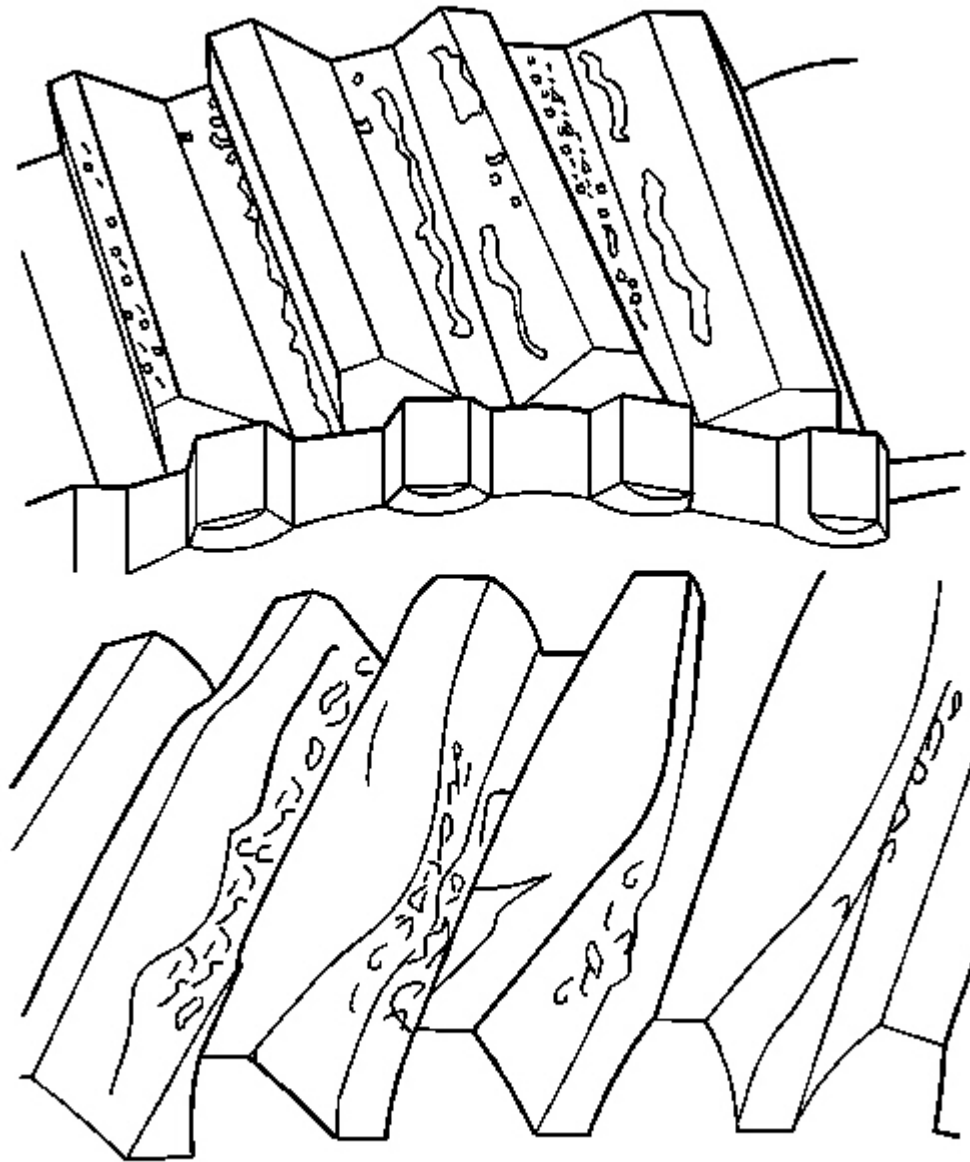

Fig. 157: Identifying Overheated Gears
Courtesy of GENERAL MOTORS CORP.

28. Inspect the gears for damage from overheating.

Overheating damage is identified by grayish to bluish black discoloration of the gear, burnt

oil and reduced hardness. Due to the reduction in hardness, there is scored or grooved flank wear in the direction of sliding, particularly in the tip and root zones. If there is extreme overheating, the material softens, causing distortion of the gear teeth, bending the teeth from thermal distortion.

29. If damage from overheating is present, replace or repair the affected parts.

Overheating is caused by the following conditions:

- Temporary or complete lack of lubrication - low oil level
- Very high peripheral speeds
- Insufficient tooth clearance

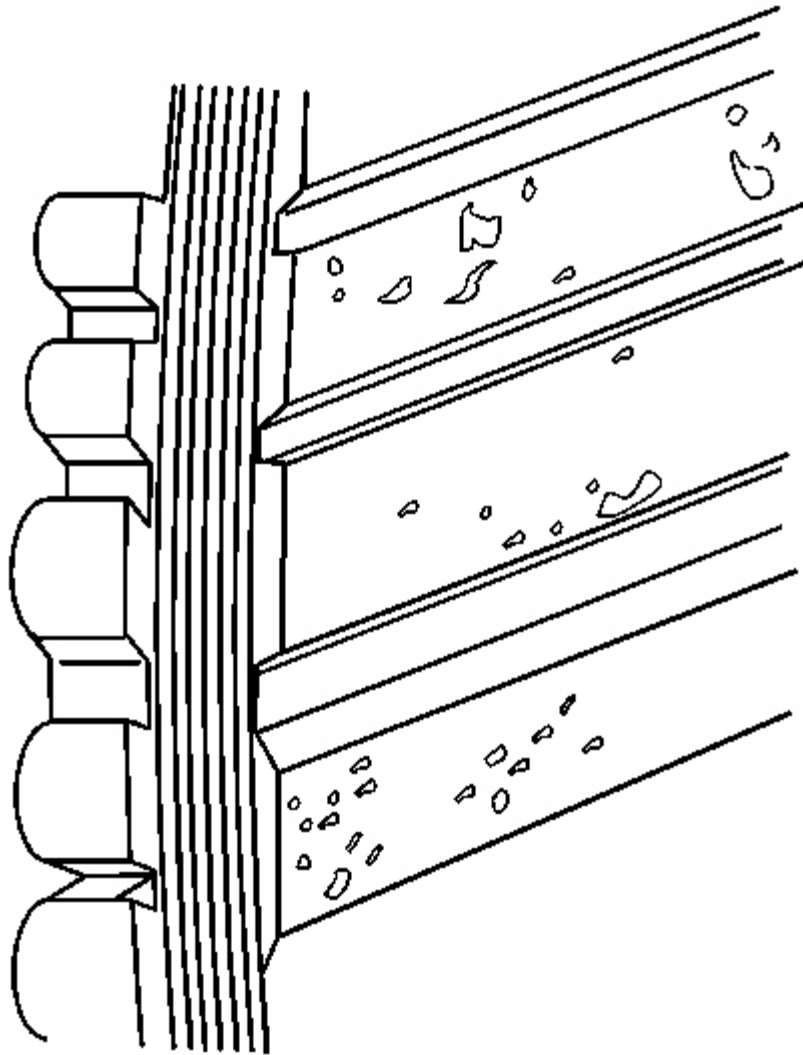

Fig. 158: Identifying Gear Corrosion
Courtesy of GENERAL MOTORS CORP.

30. Inspect the gears for corrosion.

Corrosion is brownish red to black spots, sometimes with local material loss on the flank. If corrosion has not caused material loss to the flank, the sliding and rolling action of the flank can help to remove some of the corrosion.

31. If corrosion is severe, replace the affected parts.

Corrosion is caused by the following conditions:

- Water or salt water entering the transmission
- Condensation forming under unfavorable operating conditions
- Oil aging and the decomposition of corrosion inhibitors

BEARINGS AND SPACERS CLEANING AND INSPECTION

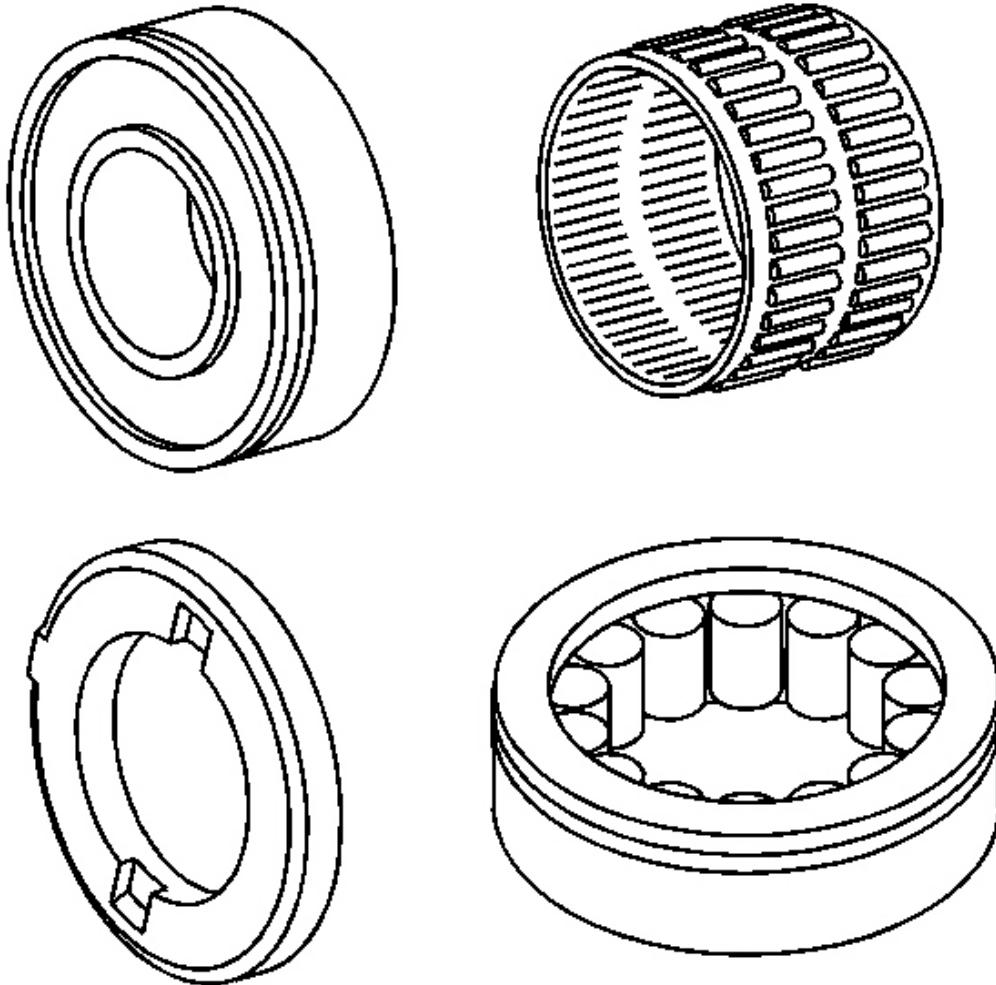

Fig. 159: View Of Bearings & Spacers
Courtesy of GENERAL MOTORS CORP.

NOTE: Do not allow the bearings to spin. Turn them slowly by hand. Spinning the bearings may damage the race and the rollers.

1. Mark or tag the bearings in order to ensure they are properly installed in the correct location.
2. Clean all of the roller bearings, needle bearings and ball bearings in a suitable solvent and air dry all the parts.
3. Inspect the bearings and races for the following conditions:
 - Roughness
 - Brinelling
 - Pitting
4. Inspect the cage bearings for being bent or for having damaged cages.
5. Replace the bearings with any of the above conditions.
6. Replace mated bearing parts when only one part is damaged.
7. Inspect the thrust washers for scoring or wear.
8. Replace any faulty thrust washers.
9. Do not file surfaces which have been hardened and precision ground.

SYNCHRONIZERS CLEANING AND INSPECTION

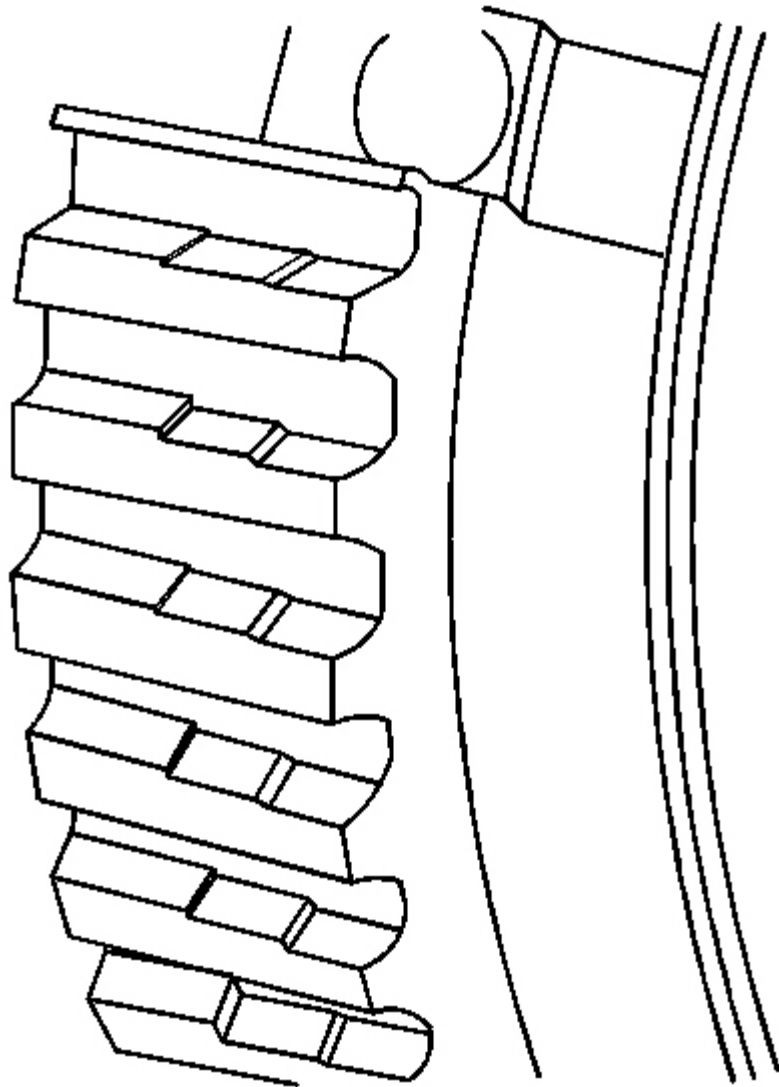

Fig. 160: Identifying Stepped Effect On The Synchronizers Teeth
Courtesy of GENERAL MOTORS CORP.

IMPORTANT: When you service the synchronizers, retain them in the order that they are removed. Mark the parts to ensure the correct position for inspection and assembly.

2007 Hummer H3

2007 TRANSMISSION Manual Transmission - Aisin AR5 - H3

1. Clean all the synchronizer parts in a suitable cleaning solvent and air dry all the parts.
2. Inspect the 1st/2nd gear and the 3rd/4th gear synchronizer hubs for a force fit on the output shaft.
3. Replace synchronizer hubs that do not require a force fit.
4. Inspect the synchronizer hub for wear on the external splines. A stepped effect on the teeth, due to wear, may cause shift concerns.
5. Replace a worn hub.
6. Correct the cause, such as, but not limited to the following conditions:
 - Engine related vibrations
 - Driving at a low speed in a high gear
 - Defective vibration damper or crankshaft

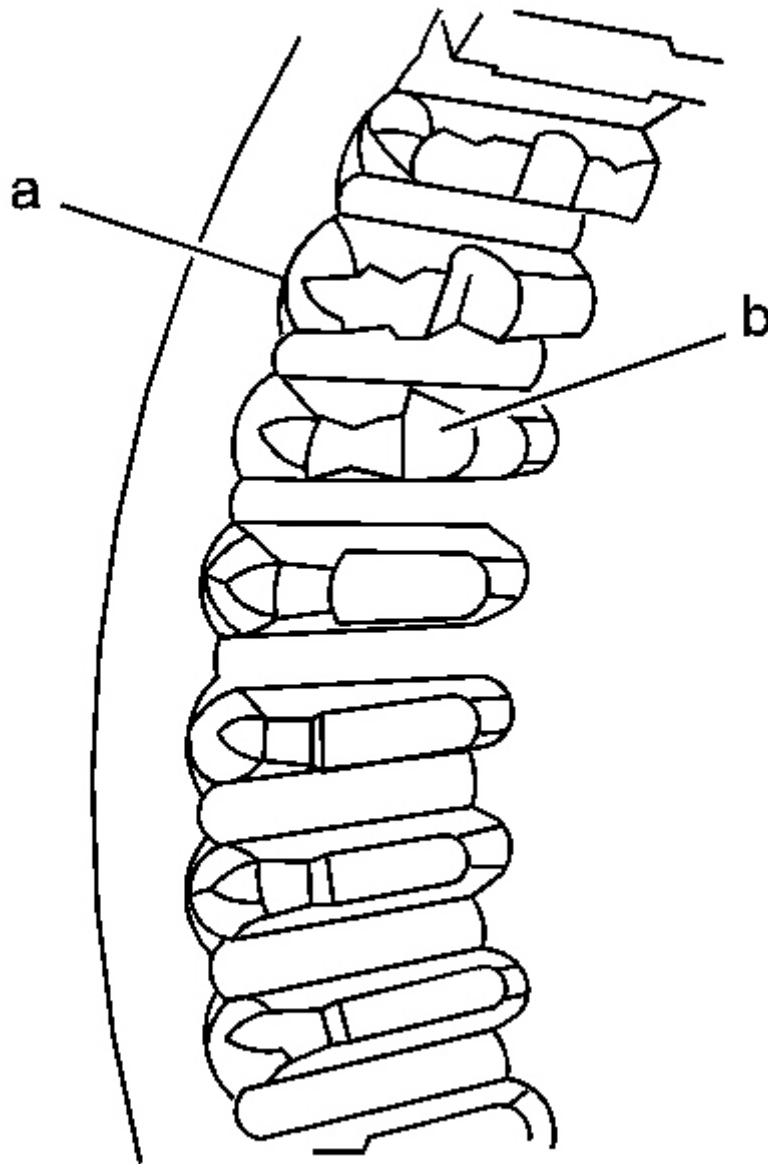

Fig. 161: Identifying Damage On Synchronizer Sleeve Teeth
Courtesy of GENERAL MOTORS CORP.

7. Inspect the synchronizer sleeve teeth (a) for the following conditions, which may cause shift concerns:

- Grated teeth
 - Chipped off teeth
 - Blunted teeth
8. Inspect the synchronizer sleeve detent stops (b) for wear or for being chipped off.
 9. Replace the synchronizer assembly if the teeth or stops show the above conditions.

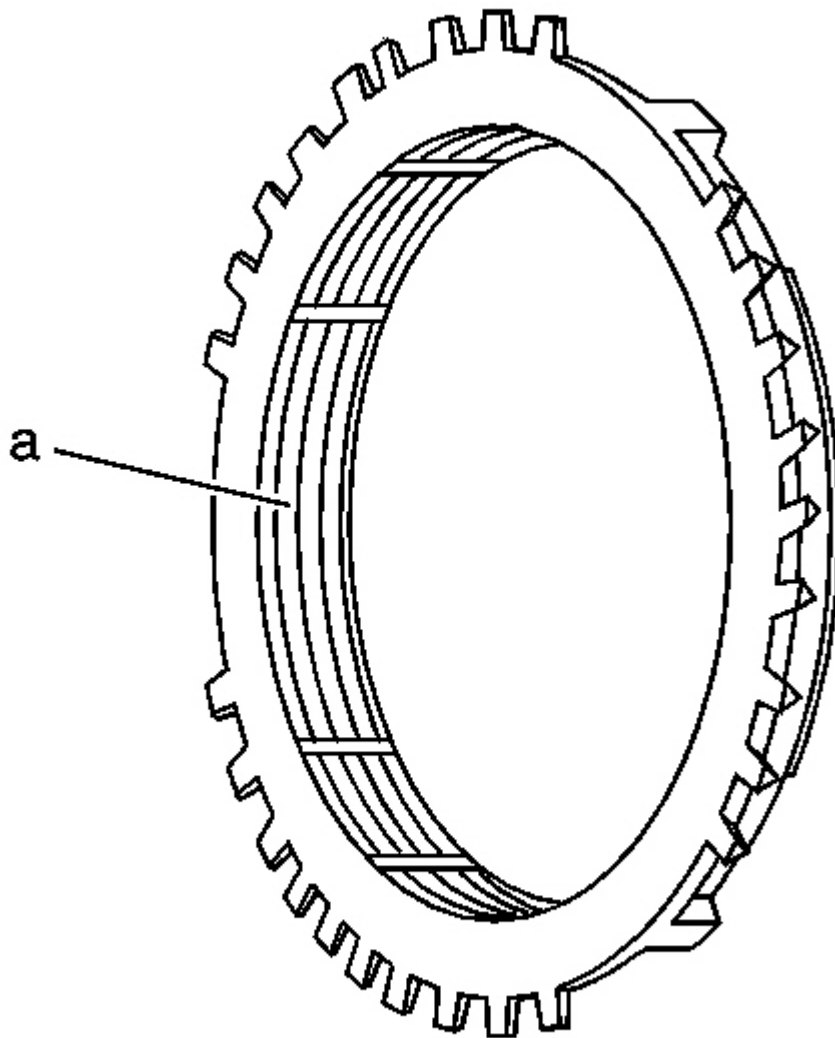

Fig. 162: View Of Synchronizer Blocker Rings Grooves

Courtesy of GENERAL MOTORS CORP.

10. Inspect the synchronizer blocker rings for worn away grooves (a).
11. Replace the blocker ring assembly if the blocker ring grooves are worn.

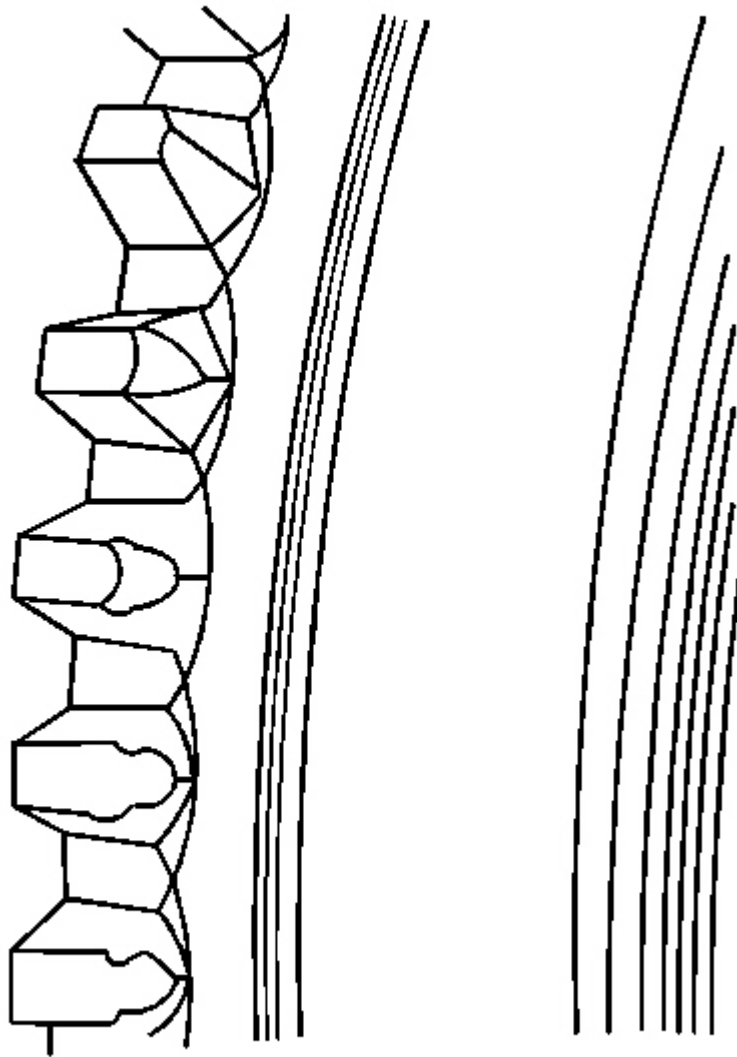

Fig. 163: Inspecting Synchronizer Blocker Rings For Wear Or Damage
Courtesy of GENERAL MOTORS CORP.

12. Inspect the synchronizer blocker rings for worn shift teeth.
13. Inspect the internal ring for being warped or damaged.
14. Inspect the outer ring for worn grooves.
15. Replace the synchronizer assembly for any of the above conditions.

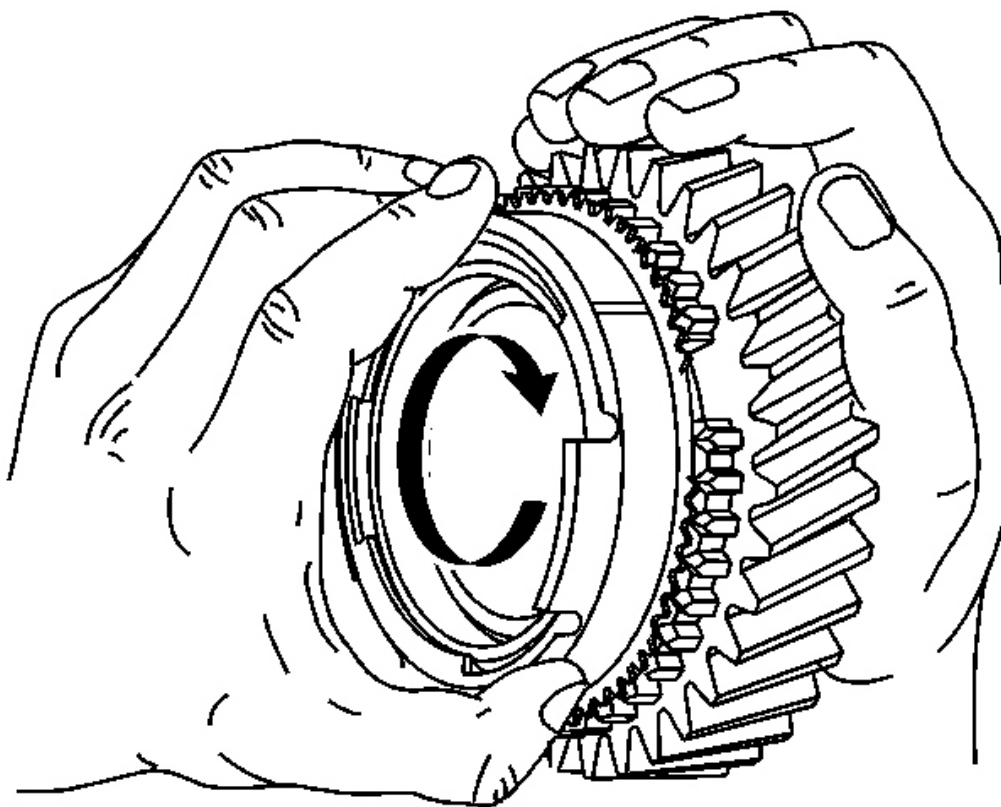

Fig. 164: Ensuring Blocking Ring Locks
Courtesy of GENERAL MOTORS CORP.

16. Install the synchronizer blocking rings to the correct speed gear.
17. Inspect the braking effect of the blocking ring. Turn the blocking ring in one direction while pushing to the gear cone. Ensure the ring locks.
18. If the ring does not lock, replace the synchronizer assembly.

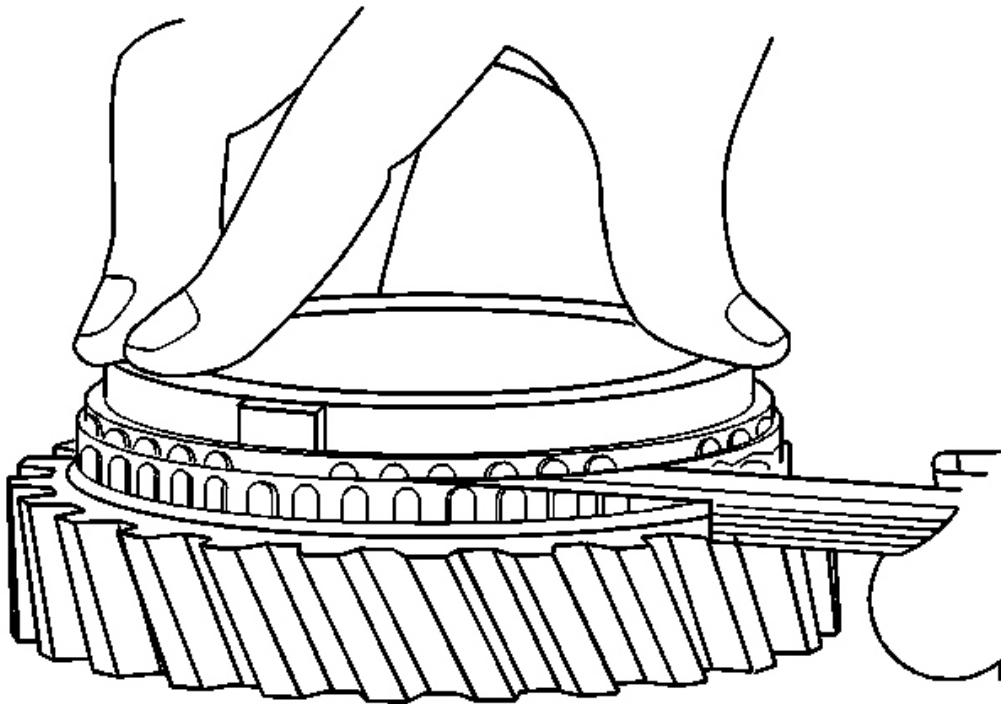

Fig. 165: Measuring Blocker Ring To Gear Clearance
Courtesy of GENERAL MOTORS CORP.

19. Except for 5th gear, measure the blocker ring to gear clearance.
 1. Assemble the correct blocker ring to the correct gear.
 2. Apply pressure to the blocker ring to fully seat the ring.
 3. Using a feeler gage, measure between the blocker ring teeth and the teeth on the gear.

Specification:

- Minimum Clearance 4th Gear: 0.8 mm (0.031 in)
 - Minimum Clearance 3rd Gear: 0.8 mm (0.031 in)
 - Minimum Clearance 2nd Gear: 0.8 mm (0.031 in)
 - Minimum Clearance 1st Gear: 0.8 mm (0.031 in)
20. If using a NEW blocker ring and the standard clearance can not be obtained, replace the gear.

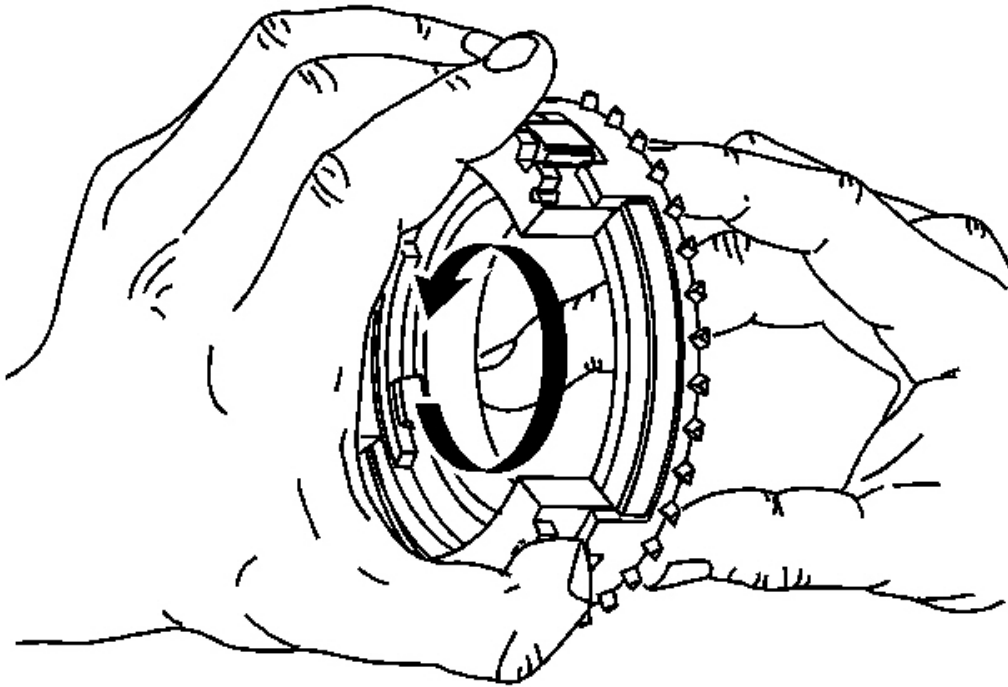

Fig. 166: Ensuring Reverse Synchronizer Inner Ring, Internal Ring & Outer Ring Lock

Courtesy of GENERAL MOTORS CORP.

21. Install the reverse synchronizer inner ring, internal ring and outer ring to the 5th synchronizer ring.
22. Inspect the braking effect of the blocking ring. Turn the reverse outer ring in one direction while pushing to the 5th synchronizer ring. Ensure the ring locks.
23. If the ring does not lock, replace the synchronizer assembly.

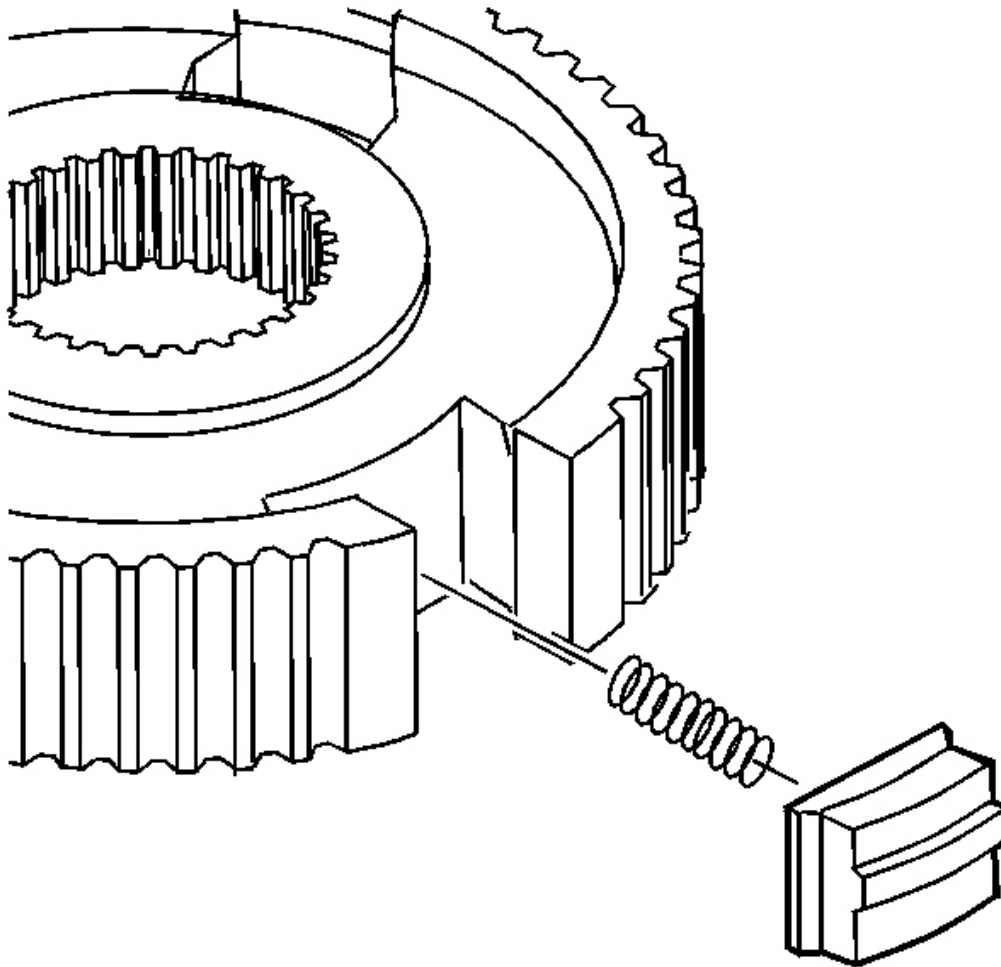

Fig. 167: View Of Pressure Pieces
Courtesy of GENERAL MOTORS CORP.

24. Inspect the pressure pieces for wear or damage.
25. Inspect the springs for distortion.
26. Replace the worn pressure pieces or faulty springs.

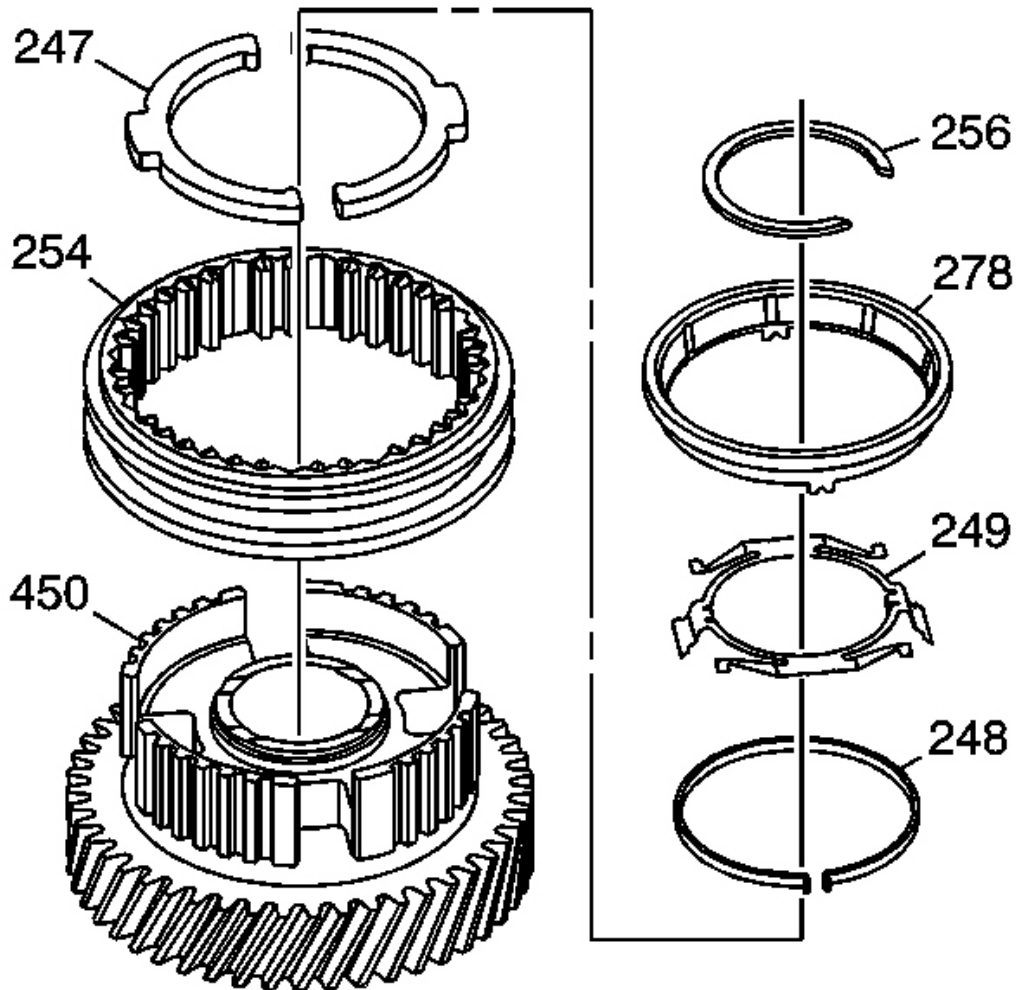

Fig. 168: View Of Synchronizer Assembly Components
 Courtesy of GENERAL MOTORS CORP.

27. Inspect the springs for distortion.
28. Inspect the inserts for wear.
29. Replace any worn components.

SHIFT SHAFT AND SHIFT FORK CLEANING AND INSPECTION

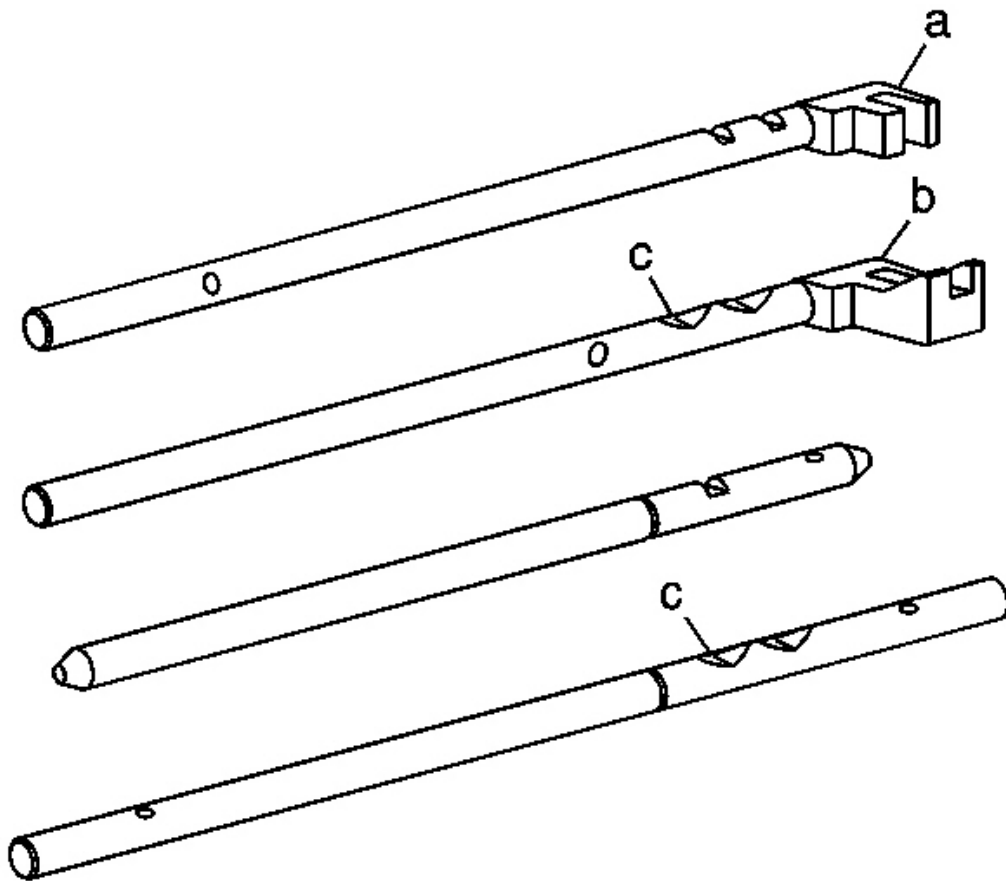

Fig. 169: View Of Shift Shaft Inspection Areas
Courtesy of GENERAL MOTORS CORP.

1. Clean all of the shift parts in a suitable cleaning solvent and air dry the parts.
2. Roll the shift shafts on a flat surface to inspect them for being bent.
3. Inspect the shift shafts for wear or scoring.
4. If light scoring is present, dress the area using a soft stone. Do not use a file.
5. Inspect the roll pin in the shift shaft gate (b) for being loose.
6. Inspect the gates (a) for damage or wear.
7. Inspect the shift shaft detents (c) for excessive rounding, chipping or distortion.
8. Replace the shift shaft if faulty.

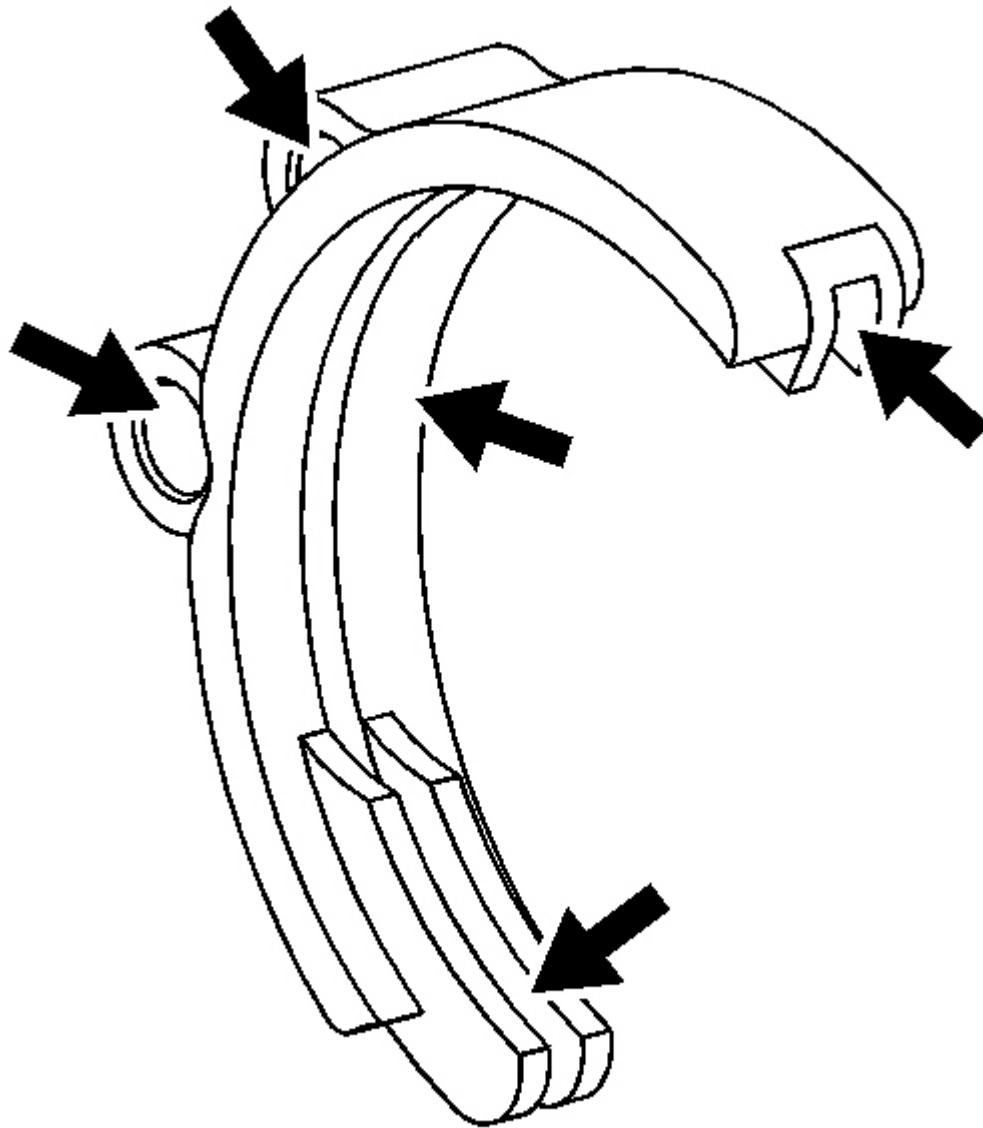

Fig. 170: View Of 1st/2nd Shift Fork Inspection Areas
Courtesy of GENERAL MOTORS CORP.

9. Inspect the 1st/2nd shift fork for scoring, distortion or wear through the hardened surface.
10. Inspect for a bent shift fork.
11. Inspect for cracks in the shift fork.

12. Inspect the shift rail holes for excessive wear.
13. Replace the shift fork if faulty.

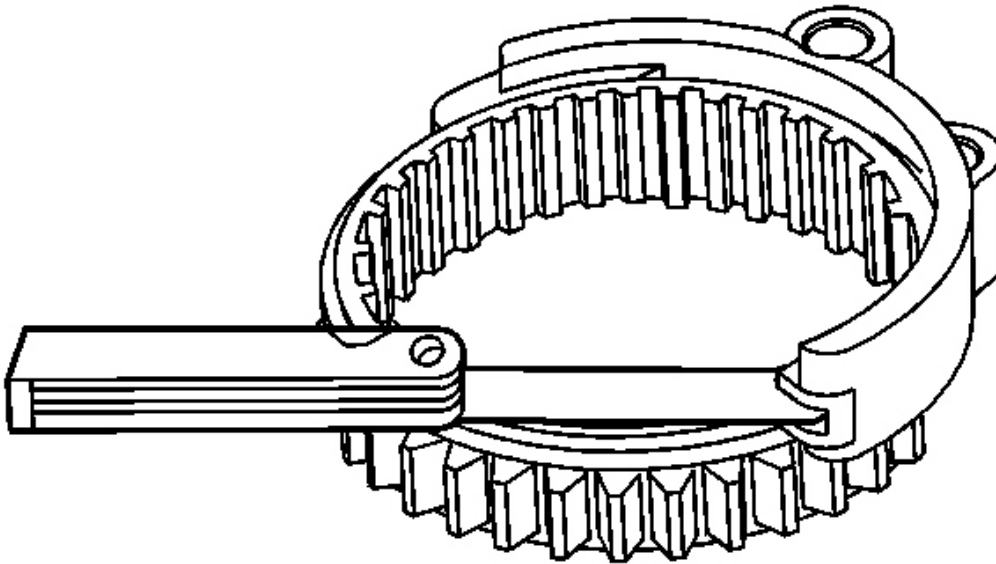

Fig. 171: Checking Clearance Between Reverse Gear & Shift Fork
Courtesy of GENERAL MOTORS CORP.

14. Using a feeler gage, measure the clearance between the reverse gear and the shift fork.

Specification: Maximum Clearance: 1.0 mm (0.039 in)

15. If the clearance exceeds the maximum, replace the shift fork or the reverse gear.

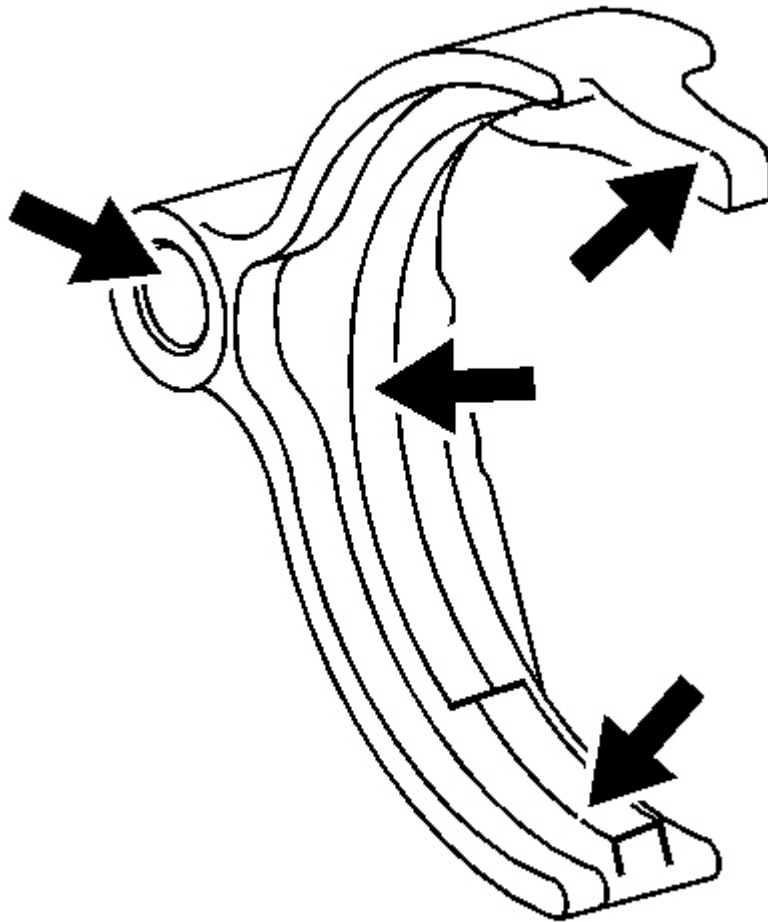

Fig. 172: View Of 3rd/4th Shift Fork Inspection Areas
Courtesy of GENERAL MOTORS CORP.

16. Inspect the 3rd/4th shift fork for scoring, distortion or wear through the hardened surface.
17. Inspect for a bent shift fork.
18. Inspect for cracks in the shift fork.
19. Inspect the shift rail hole for excessive wear.
20. Replace the shift fork if faulty.

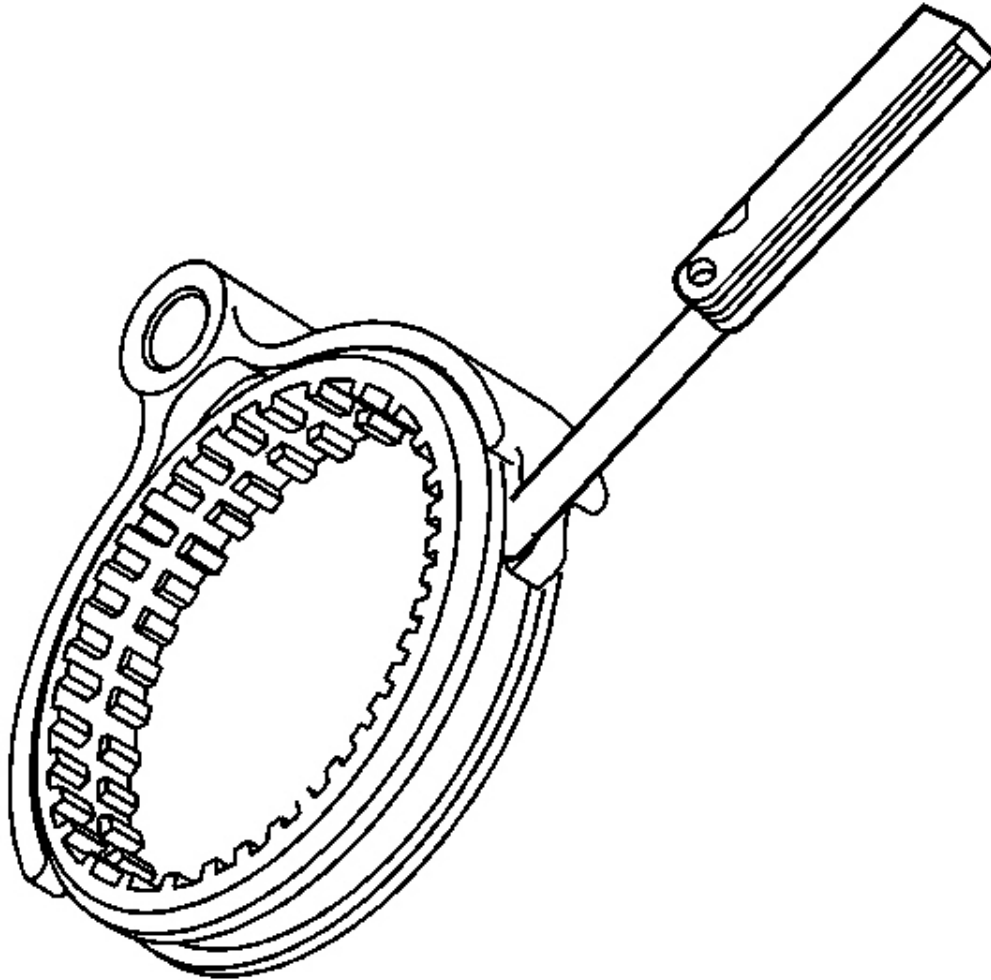

Fig. 173: Measuring Clearance Between 3rd/4th Synchronizer Sleeve & Shift Fork
Courtesy of GENERAL MOTORS CORP.

21. Using a feeler gage, measure the clearance between the 3rd/4th synchronizer sleeve and the shift fork.

Specification: Maximum Clearance: 1.0 mm (0.039 in)

22. If the clearance exceeds the maximum, replace the shift fork or the sleeve.

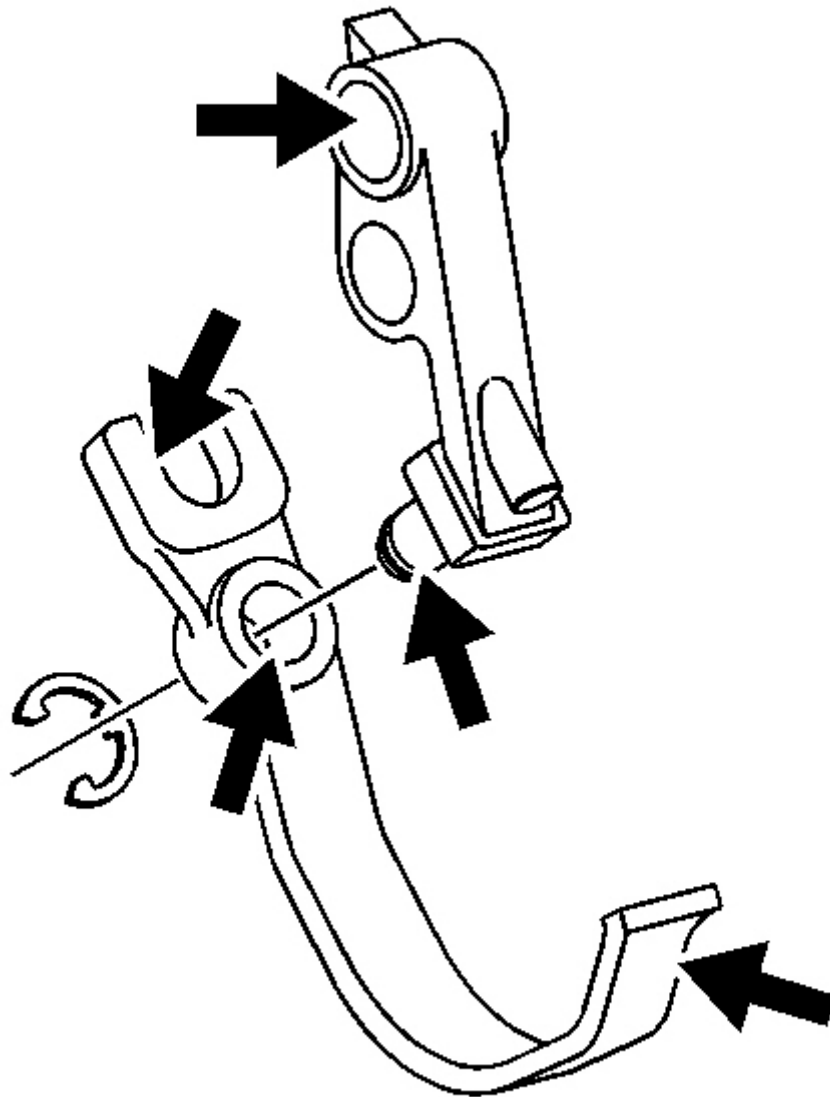

Fig. 174: Inspection Areas On Reverse Shift Fork & Reverse Shift Lever
Courtesy of GENERAL MOTORS CORP.

23. Inspect the reverse shift fork and the reverse shift lever for wear or damage.
24. Replace the reverse shift fork or the reverse shift lever if found faulty.

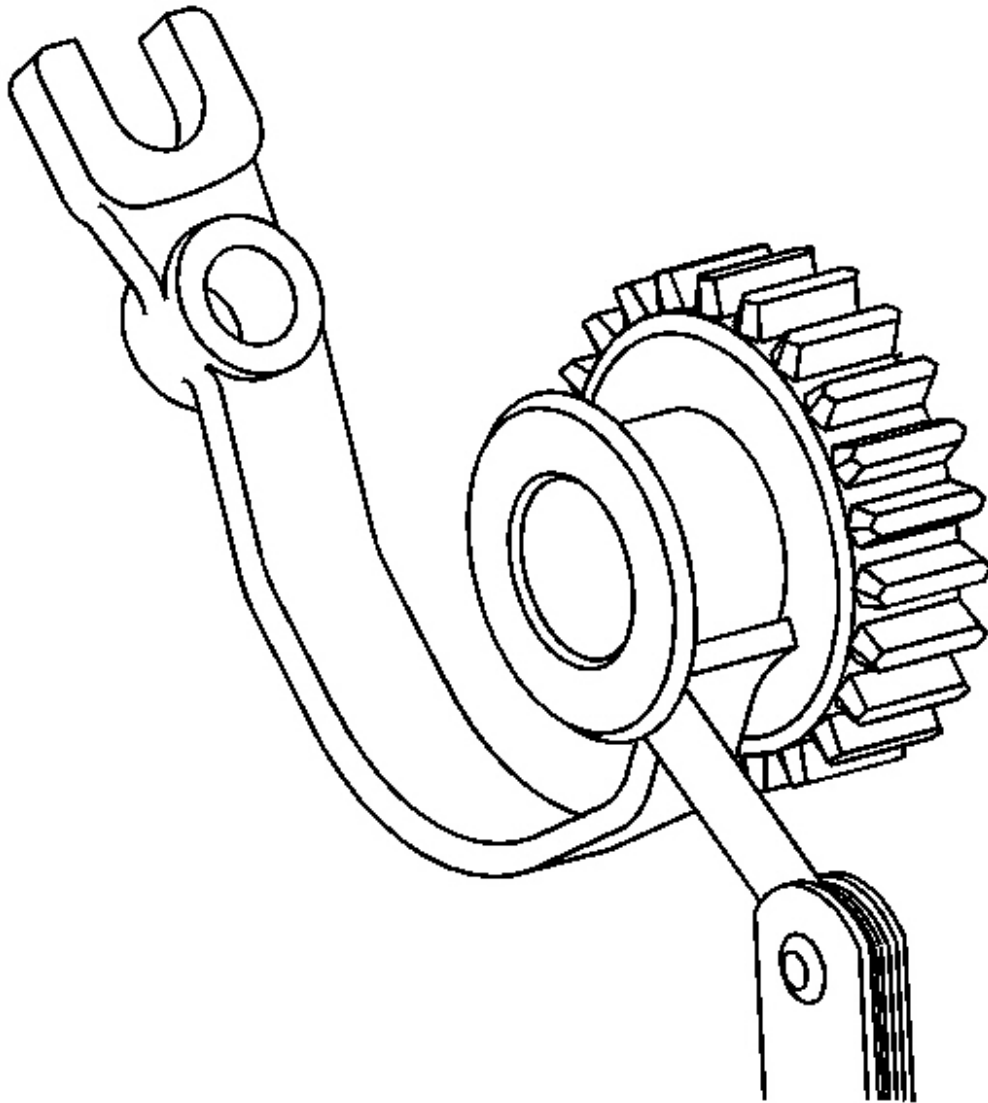

Fig. 175: Checking Clearance Between Reverse Idler Gear & Reverse Shift Fork
Courtesy of GENERAL MOTORS CORP.

25. Using a feeler gage, measure the clearance between the reverse idler gear and the reverse shift fork.

Specification:

- Standard Clearance: 0.05-0.35 mm (0.0020-0.0138 in)
- Maximum clearance: 0.50 mm (0.0197 in)

26. If the clearance exceeds the maximum, replace the shift fork or the reverse idler gear.

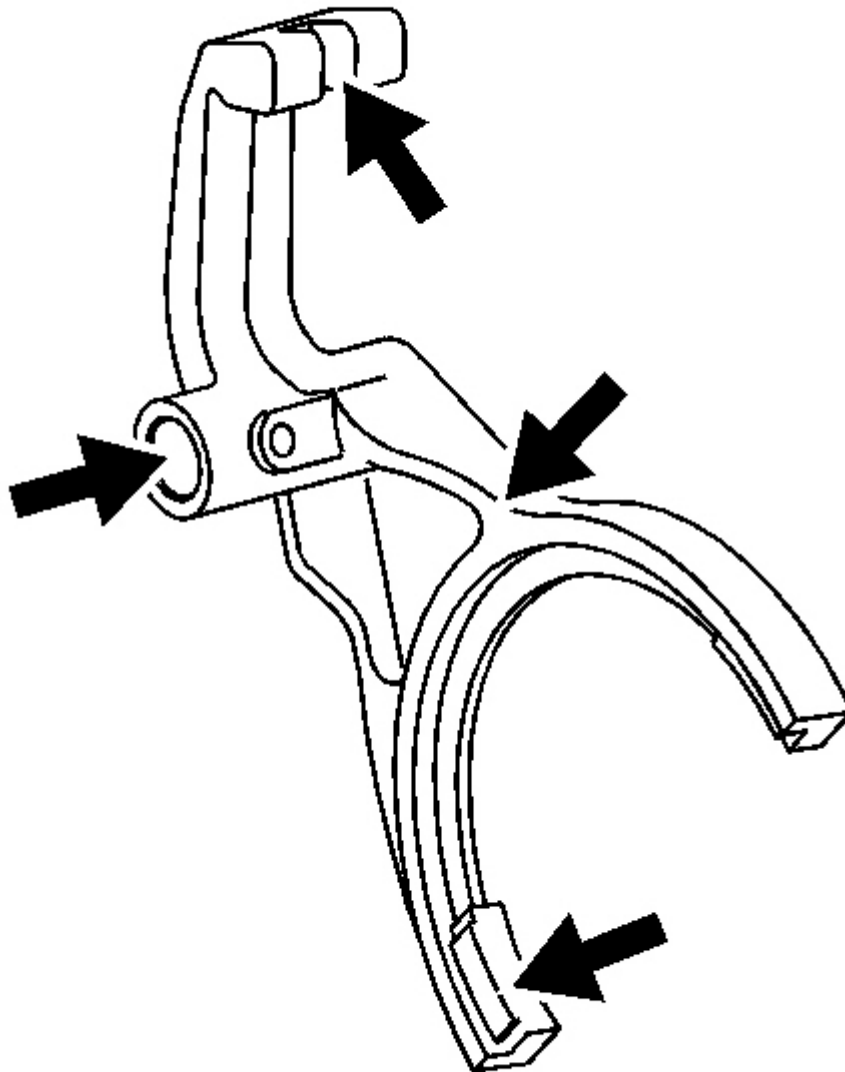

Fig. 176: Locating Inspection Areas On 5th Gear Shift Fork
Courtesy of GENERAL MOTORS CORP.

27. Inspect the 5th gear shift fork for worn pads.
28. Inspect for a bent shift fork.
29. Inspect for cracks in the shift fork.
30. Inspect the shift rail hole for excessive wear.
31. Inspect the shift fork gates for excessive wear.
32. Replace the shift fork if faulty.

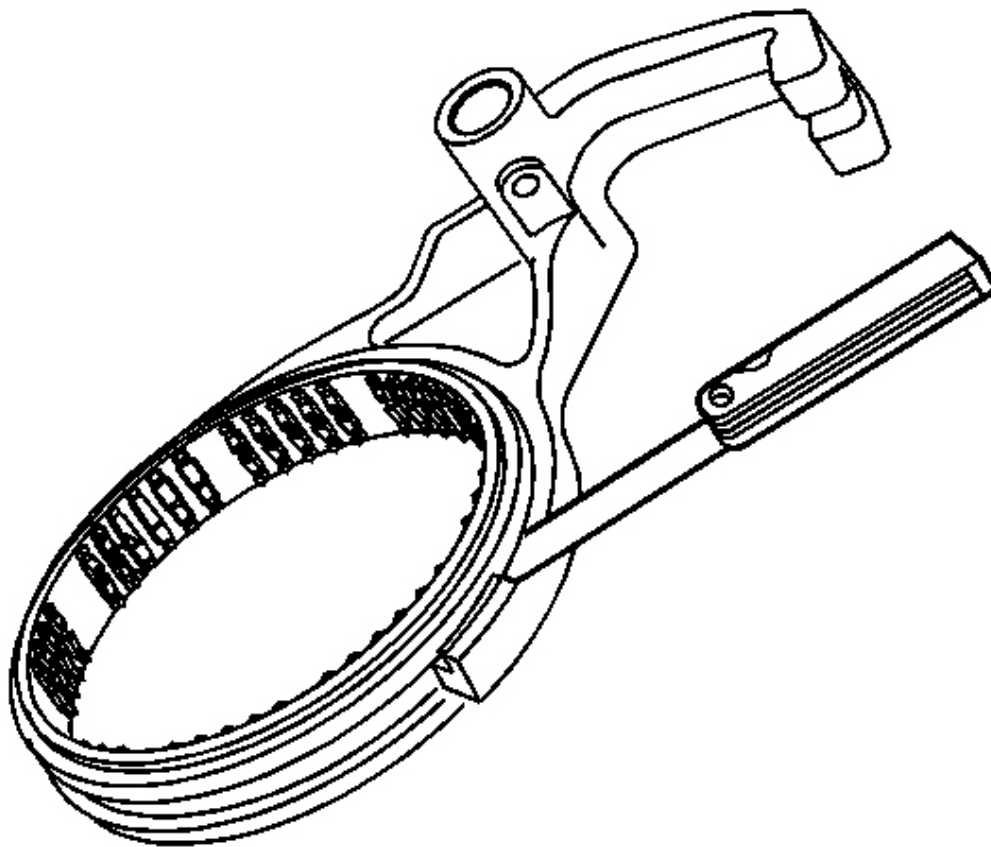

Fig. 177: Measuring Clearance Between 5th Synchronizer Sleeve & Shift Fork
Courtesy of GENERAL MOTORS CORP.

33. Using a feeler gage, measure the clearance between the 5th synchronizer sleeve and the shift fork.

Specification: Maximum Clearance: 1.0 mm (0.039 in)

34. If the clearance exceeds the maximum, replace the shift fork or the sleeve.

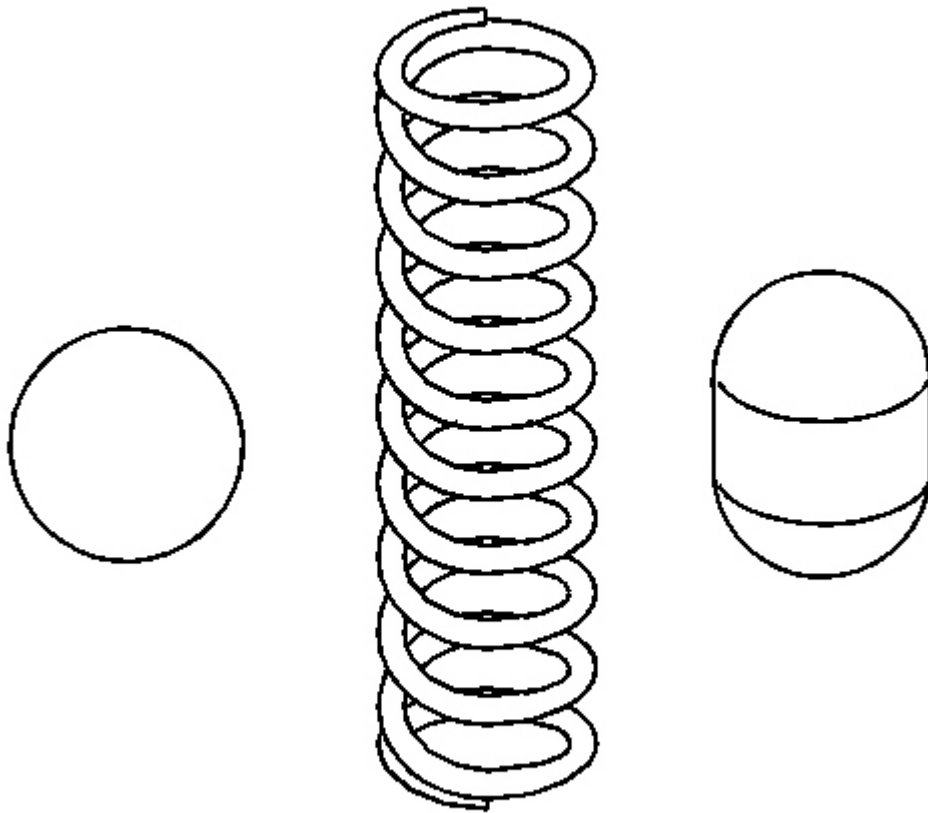

Fig. 178: Locating Detent Springs & Shift Detent Balls
Courtesy of GENERAL MOTORS CORP.

35. Inspect the interlocks for excessive wear.
36. Inspect the detent springs for distortion.
37. Inspect the shift detent balls for wear.
38. Replace the faulty parts.

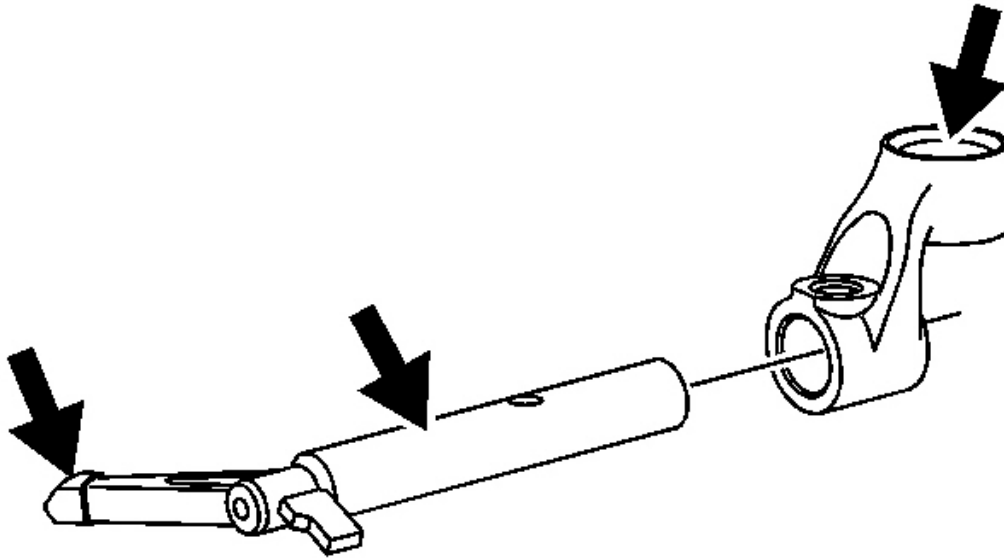

Fig. 179: Inspecting Shift Control Shaft & Lever
Courtesy of GENERAL MOTORS CORP.

39. Roll the shift control shaft on a flat surface to inspect it for being bent.
40. Inspect the shaft for wear or scoring.
41. If light scoring is present, dress the area using a soft stone. Do not use a file.
42. Inspect the shift control shaft for wear at the control lever.
43. Replace the shift control shaft if faulty.
44. Inspect the internal shift control lever for damage or excessive wear.
45. Replace the internal shift control lever if faulty.

TRANSMISSION CASE CLEANING AND INSPECTION

Clutch Housing

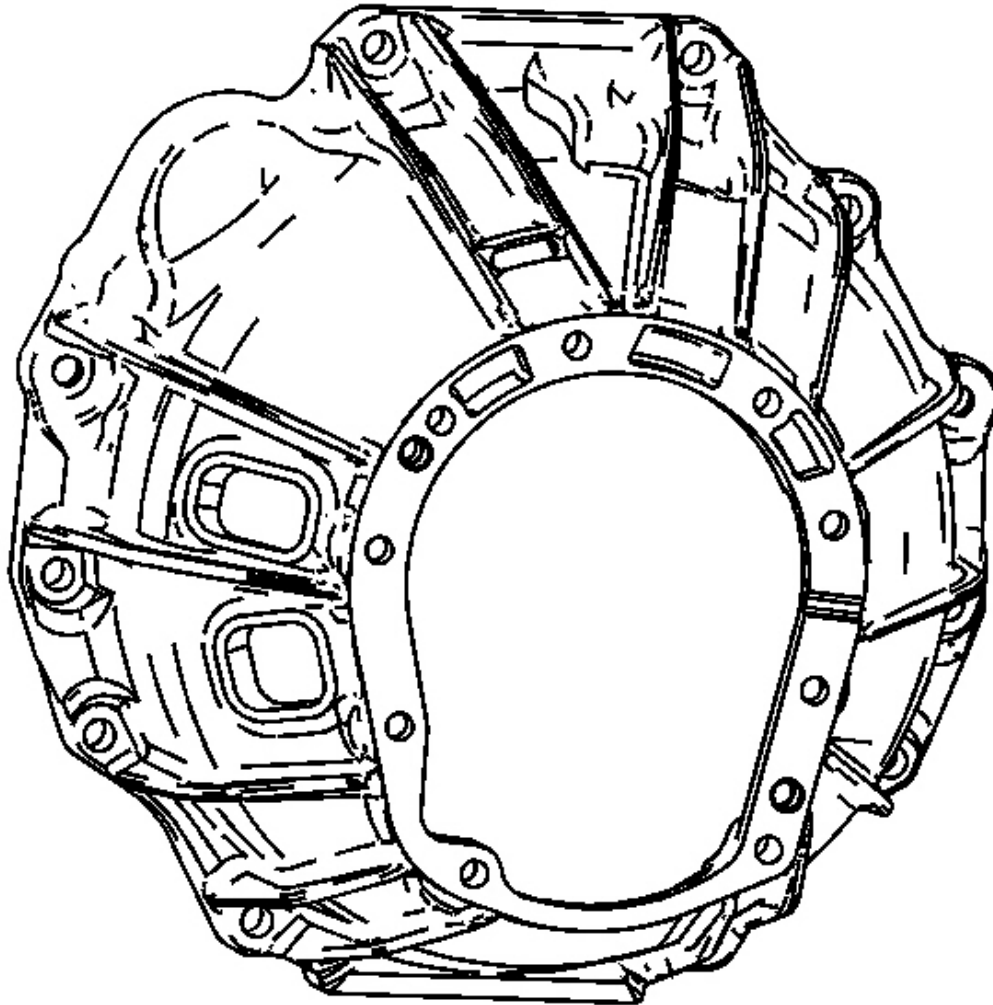

Fig. 180: Locating Inspection Areas On Clutch Housing
Courtesy of GENERAL MOTORS CORP.

1. Clean the clutch housing in a suitable solvent and air dry.
2. Inspect the clutch housing for the following conditions:
 - Cracks
 - Damaged mounting flanges
 - Damaged bolt holes

Front Case

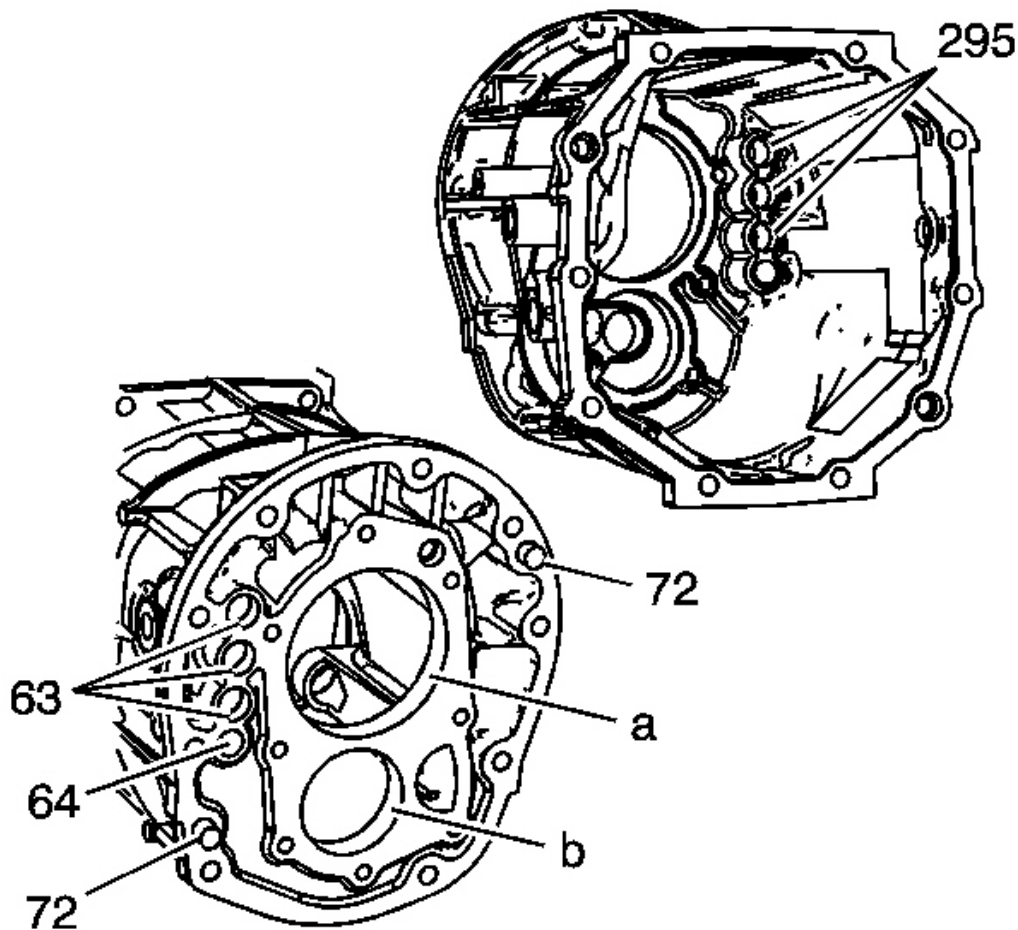

Fig. 181: View Of Front Case Inspection Areas
Courtesy of GENERAL MOTORS CORP.

1. Clean the front case in a suitable cleaning solvent and air dry.

NOTE: Refer to Machined Surface Damage Notice .

2. Remove the sealer from the case sealing surfaces.
3. Inspect the case for being broken or cracked.
4. Inspect the input shaft bearing bore (a) for the following conditions:

- A spun bearing
 - Cracks
5. Inspect the countershaft front bearing bore (b) for the following conditions:
 - A spun bearing
 - Cracks
 6. Replace the case assembly if any of the above conditions are found. The front case is only serviced with the intermediate case.
 7. Inspect the sealing surfaces for damage.
 8. Repair small scratches or nicks with a soft stone.
 9. Inspect the case threaded bolt holes for damage.
 10. Repair any damaged threads.
 11. Inspect the location pins (72) for being loose or missing.
 12. Repair or replace any damaged location pins.
 13. Inspect the shift shaft bushings (295) for excessive wear.
 14. Replace the case assembly if the shift shaft bushings (295) are faulty.
 15. Inspect the shift shaft bushing plugs (63 and 64) for leaking or damage.
 16. Replace the plugs if faulty. Refer to **Transmission Case Disassemble** and **Transmission Case Assemble**.

Extension Housing 4WD

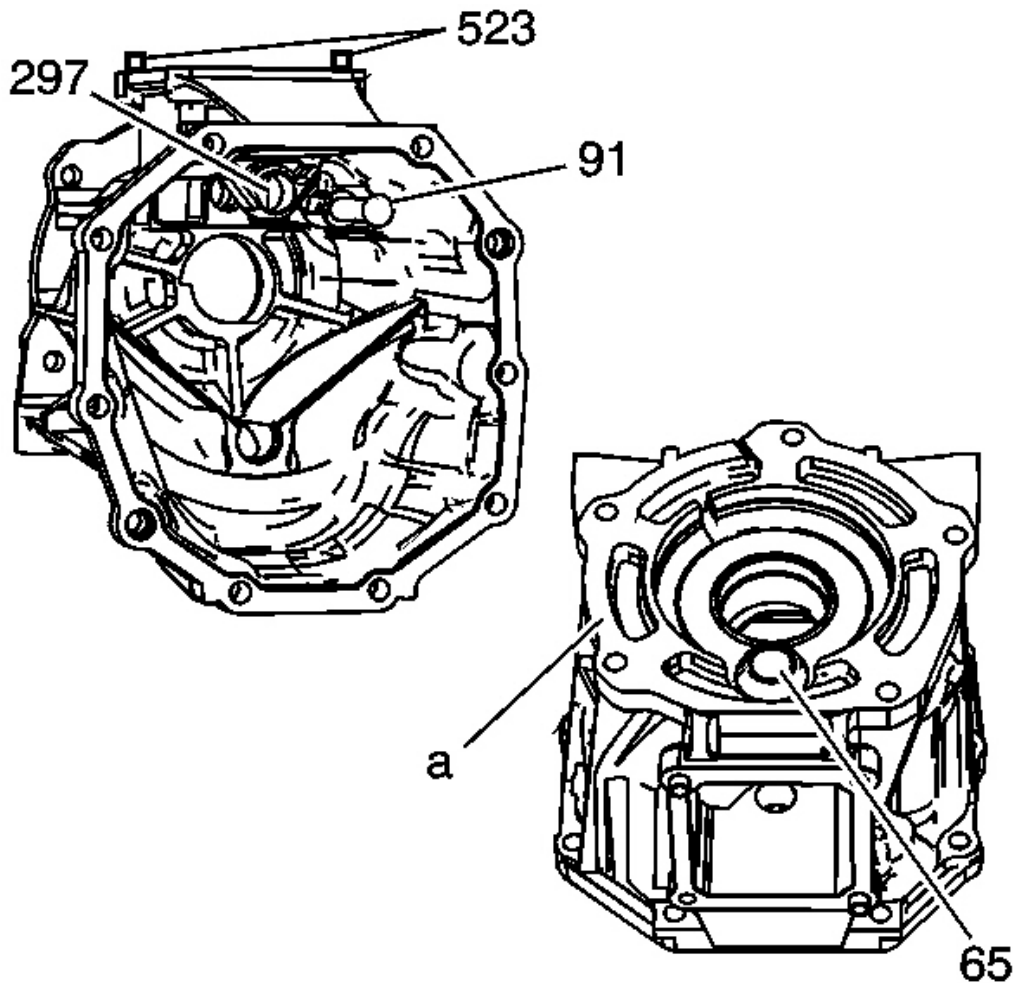

Fig. 182: Locating Extension Housing Inspection Areas - 4WD
Courtesy of GENERAL MOTORS CORP.

1. Clean the extension housing in a suitable cleaning solvent and air dry.

NOTE: Refer to Machined Surface Damage Notice .

2. Remove the sealer from the extension sealing surfaces.
3. Inspect the extension for being broken or cracked.
4. Inspect the transfer case mounting surface (a) for damage.

5. Inspect the sealing surfaces for damage.
6. Repair small scratches or nicks with a soft stone.
7. Inspect the extension threaded bolt holes for damage.
8. Repair any damaged threads.
9. Replace the extension if the above damages can not be repaired.
10. Inspect the shift control housing location pins (523) for being loose or missing.
11. Repair or replace any damaged location pins.
12. Inspect the shift shaft bushings (297) for excessive wear.
13. Replace the extension housing if the shift shaft bushings (297) are faulty.
14. Inspect the shift shaft plug (65) for leaking or damage.
15. Replace the shift shaft plug if faulty. Refer to **Transmission Extension Disassemble** and **Transmission Extension Assemble**.

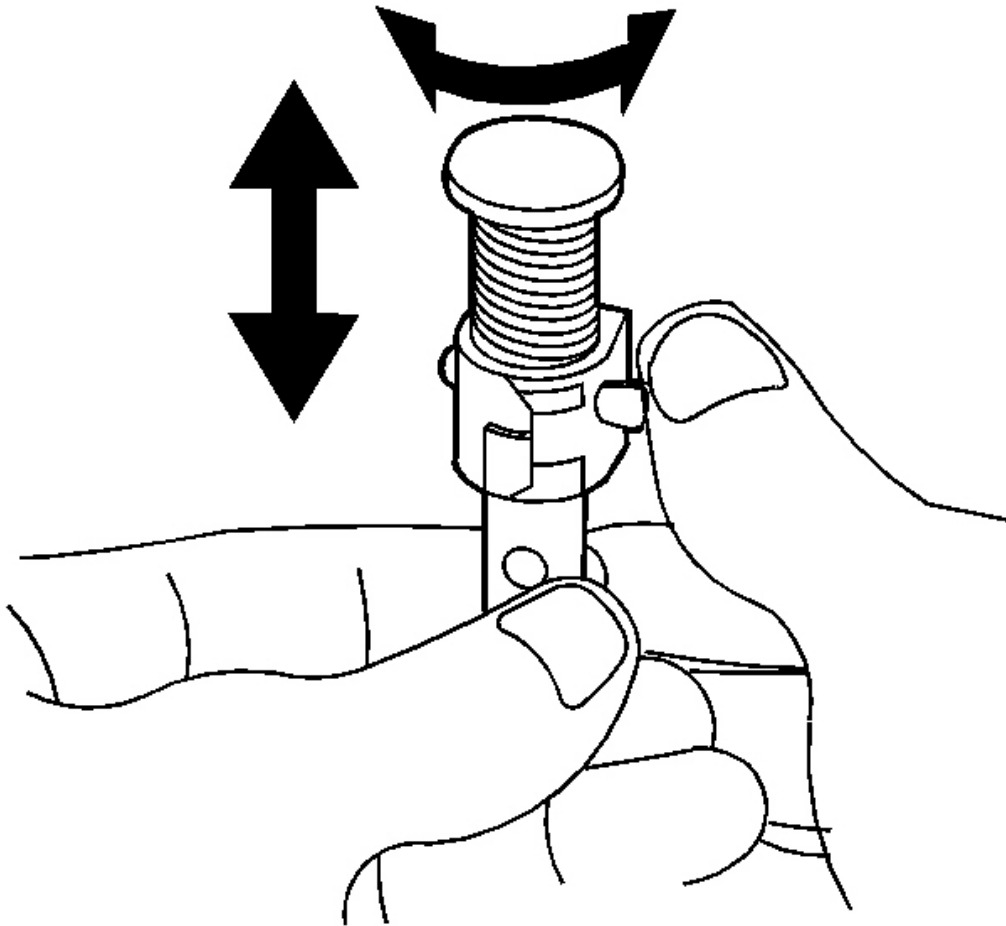

Fig. 183: Identifying Reverse Control Lever Restriction Operation
Courtesy of GENERAL MOTORS CORP.

16. Inspect the reverse control lever restriction operation for the following conditions:
 - Moves in and out
 - Rotates
17. Replace the reverse control lever restriction if faulty. Refer to **Transmission Extension Disassemble** and **Transmission Extension Assemble**.

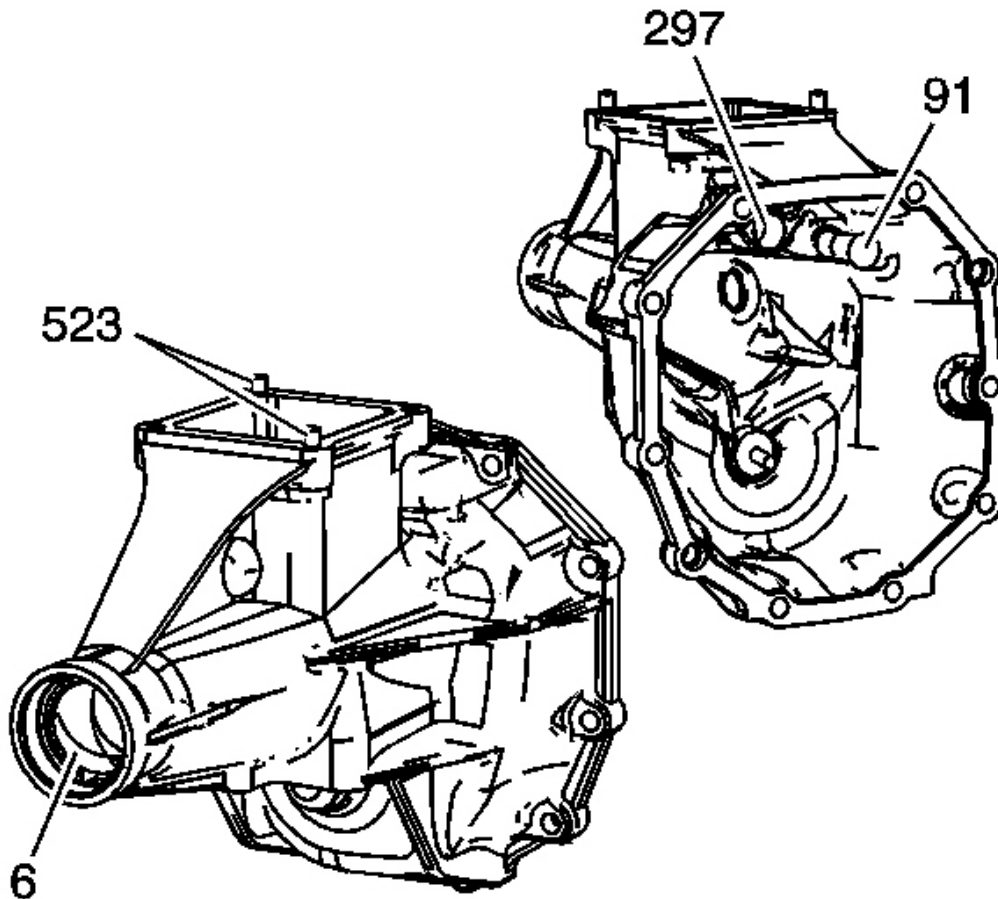

Fig. 184: Identifying Extension Housing Inspection Areas - RWD
Courtesy of GENERAL MOTORS CORP.

1. Clean the extension housing in a suitable cleaning solvent and air dry.

NOTE: Refer to Machined Surface Damage Notice .

2. Remove the sealer from the extension sealing surfaces.
3. Inspect the extension for being broken or cracked.
4. Inspect the rear bushing (6) for wear or damage. The bushing is serviced only with the extension housing.
5. Inspect the shift shaft bushings (297) for excessive wear.

6. Replace the extension if any of the above conditions are found.
7. Inspect the sealing surfaces for damage.
8. Repair small scratches or nicks with a soft stone.
9. Inspect the case threaded bolt holes for damage.
10. Repair any damaged threads.
11. Inspect the shift control housing location pins (523) for being loose or missing.
12. Repair or replace any damaged location pins.

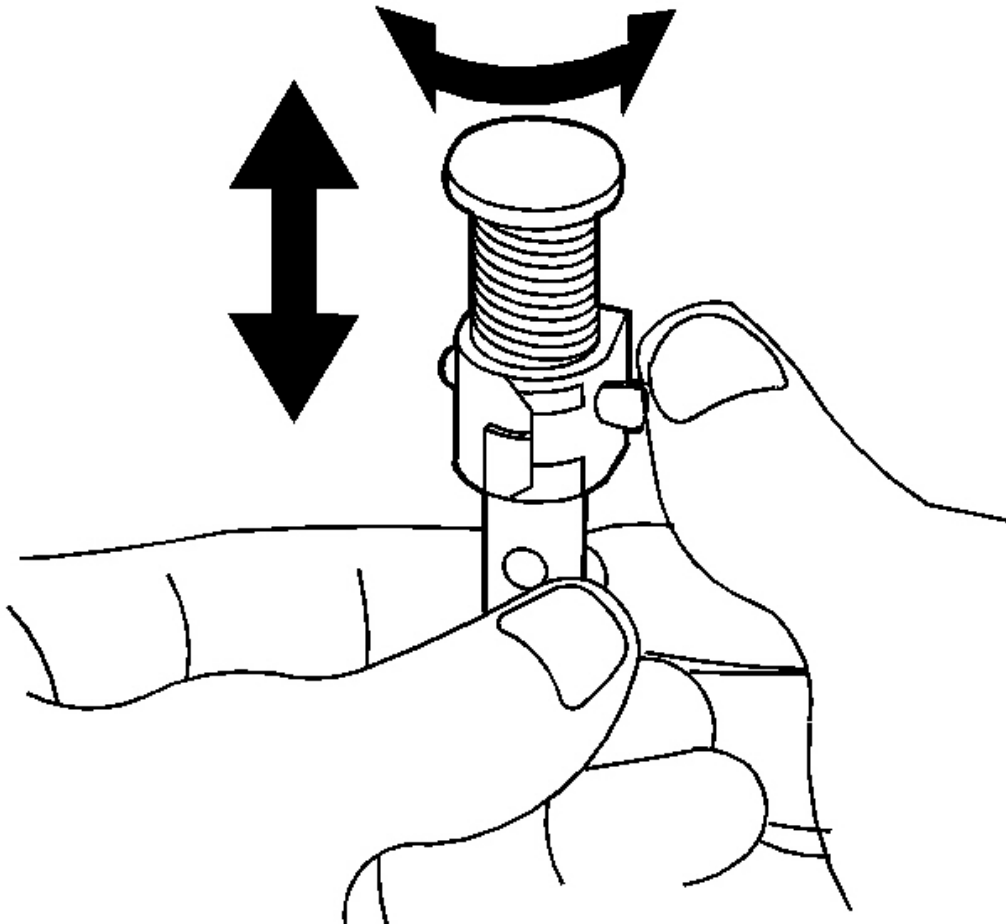

Fig. 185: Identifying Reverse Control Lever Restriction Operation
Courtesy of GENERAL MOTORS CORP.

13. Inspect the reverse control lever restriction operation for the following conditions:
 - Moves in and out
 - Rotates
14. Replace the reverse control lever restriction if faulty. Refer to **Transmission Extension Disassemble** and **Transmission Extension Assemble**.

Intermediate Case

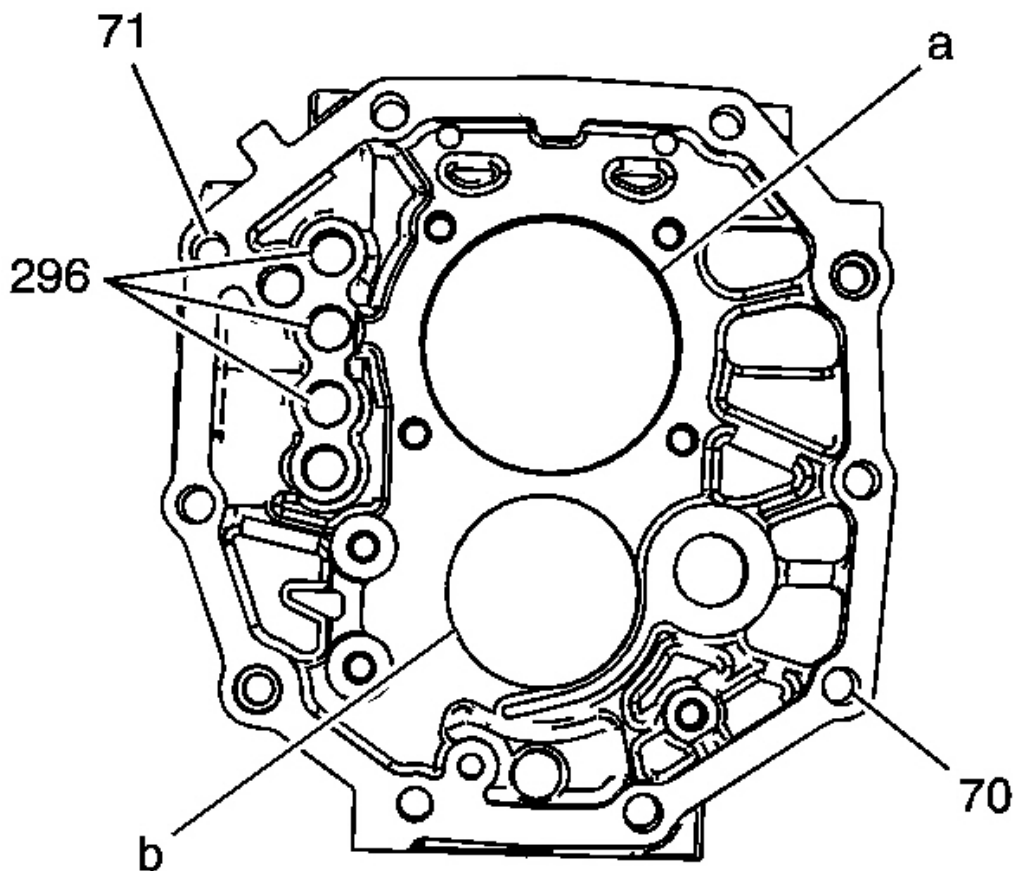

Fig. 186: View Of Intermediate Case Inspection Areas
Courtesy of GENERAL MOTORS CORP.

1. Clean the intermediate case in a suitable cleaning solvent and air dry.

NOTE: Refer to Machined Surface Damage Notice .

2. Remove the sealer from the case sealing surfaces.
3. Inspect the case for being broken or cracked.
4. Inspect the output shaft bearing bore (a) for the following conditions:
 - A spun bearing
 - Cracks
5. Inspect the countershaft rear bearing bore (b) for the following conditions:
 - A spun bearing
 - Cracks
6. Inspect the shift shaft bushings (296) for excessive wear.
7. Replace the intermediate case if any of the above conditions are found. The intermediate case is only serviced with the front case.
8. Inspect the sealing surfaces for damage.
9. Repair small scratches or nicks with a soft stone.
10. Inspect the case threaded bolt holes for damage.
11. Repair any damaged threads.
12. Inspect the location pins (71 and 72) for being loose or missing.
13. Repair or replace any damaged location pins.

Input Shaft Bearing Retainer

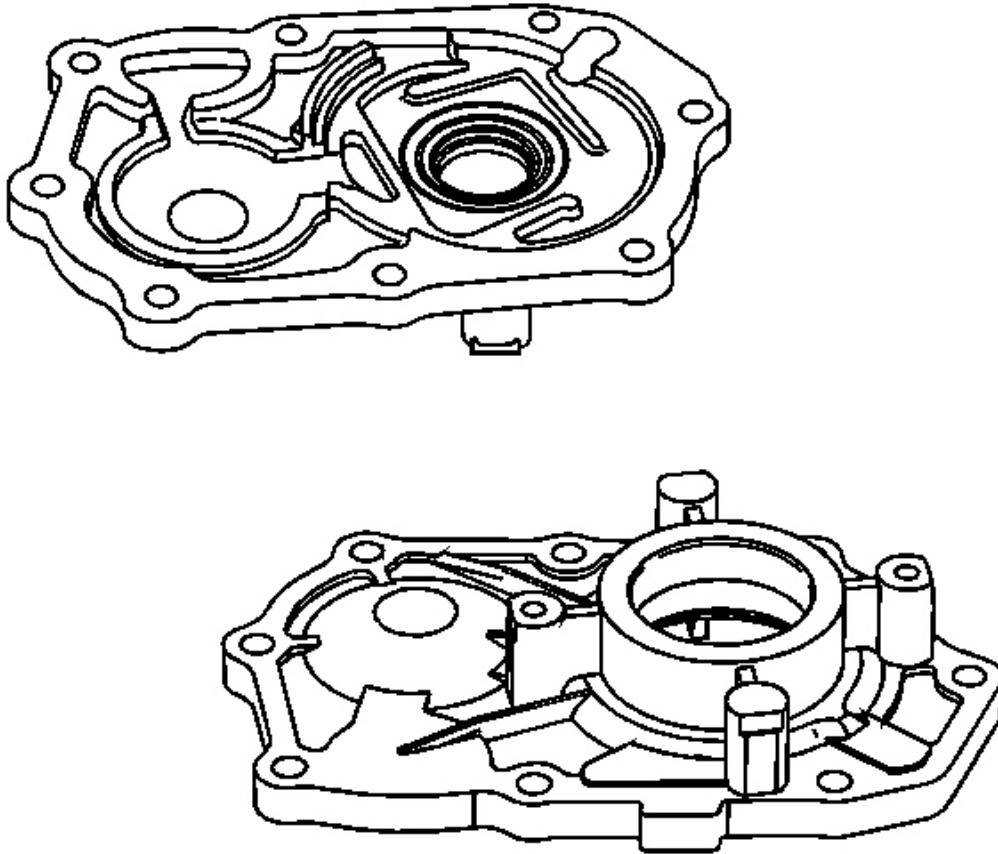

Fig. 187: View Of Input Shaft Bearing Retainer
Courtesy of GENERAL MOTORS CORP.

1. Clean the input shaft bearing retainer in a suitable cleaning solvent and air dry.

NOTE: Refer to **Machined Surface Damage Notice** .

2. Remove the sealer from the retainer sealing surfaces.
3. Inspect the bearing retainer for being broken or cracked.
4. Replace the bearing retainer if any of the above conditions are found.
5. Inspect the sealing surfaces for damage.
6. Repair small scratches or nicks with a soft stone.

SHIFT CONTROL HOUSING CLEANING AND INSPECTION

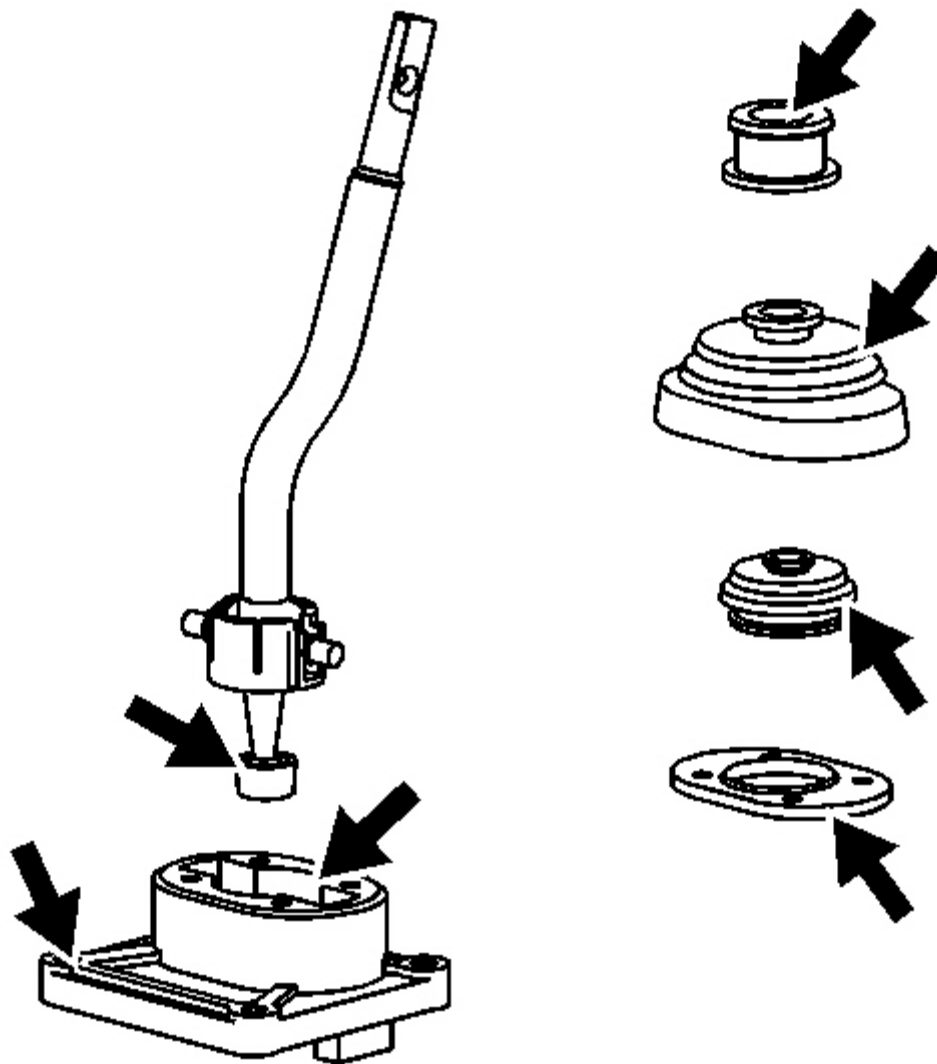

Fig. 188: View Of Inspection Areas On Shift Control Lever Components
Courtesy of GENERAL MOTORS CORP.

1. Inspect the shift boots and seals for cuts or tears.
2. Replace any faulty shift boot or seal.
3. Inspect the shift control lever for the following conditions:

- Cracked or damaged bushing
 - Cracked or damaged spring seat
 - Worn swivel pins
 - Damaged threads
 - Bent or cracked lever
4. Replace the shift control lever assembly if any of the above conditions are found.
 5. Inspect the shift control housing for the following conditions:
 - Worn or damaged shift control lever plungers
 - Missing or damaged shift control lever shaft springs
 - Worn spring seat surface
 6. Replace the shift control housing as an assembly if any of the above conditions are found.

SYNCHRONIZERS ASSEMBLE

Reverse/5th Gear Synchronizer

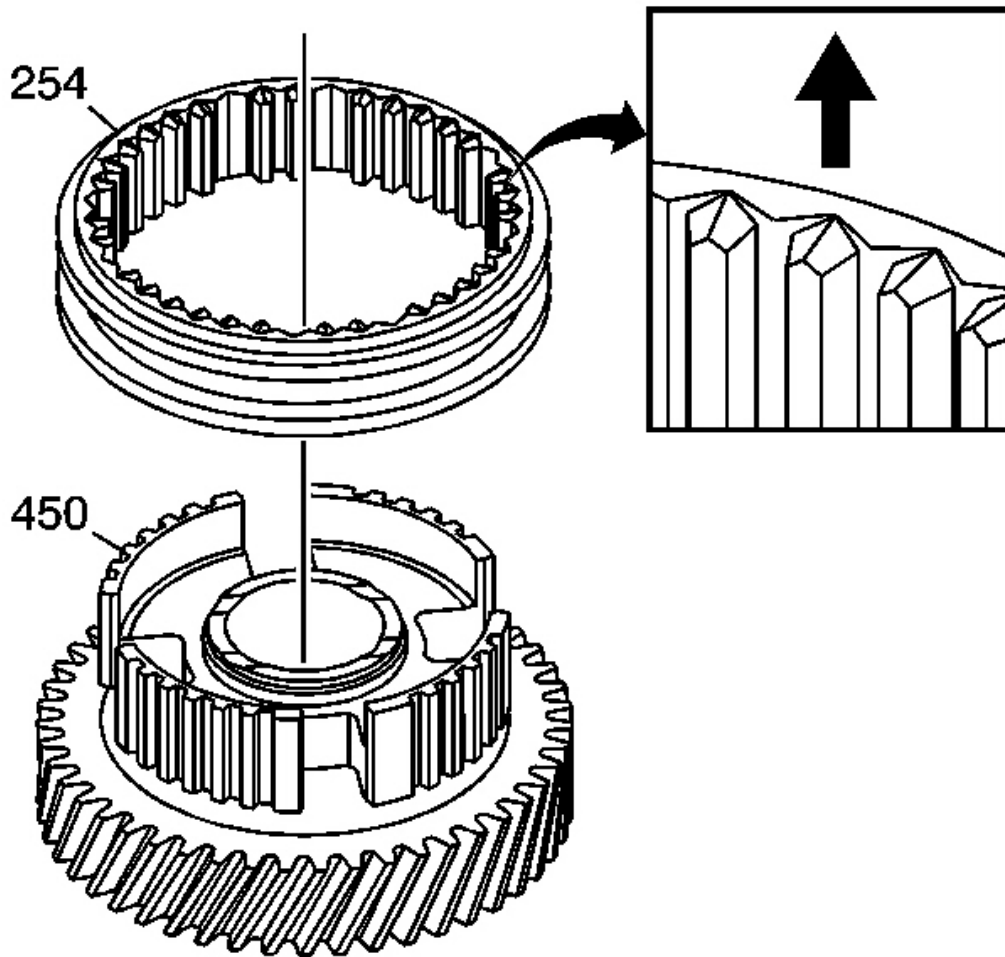

Fig. 189: Installing 5th/Reverse Synchronizer Sleeve On 5th Countershaft Gear
Courtesy of GENERAL MOTORS CORP.

1. Install the 5th/reverse synchronizer sleeve (254) onto the 5th countershaft gear with the chamfer side of the teeth up.

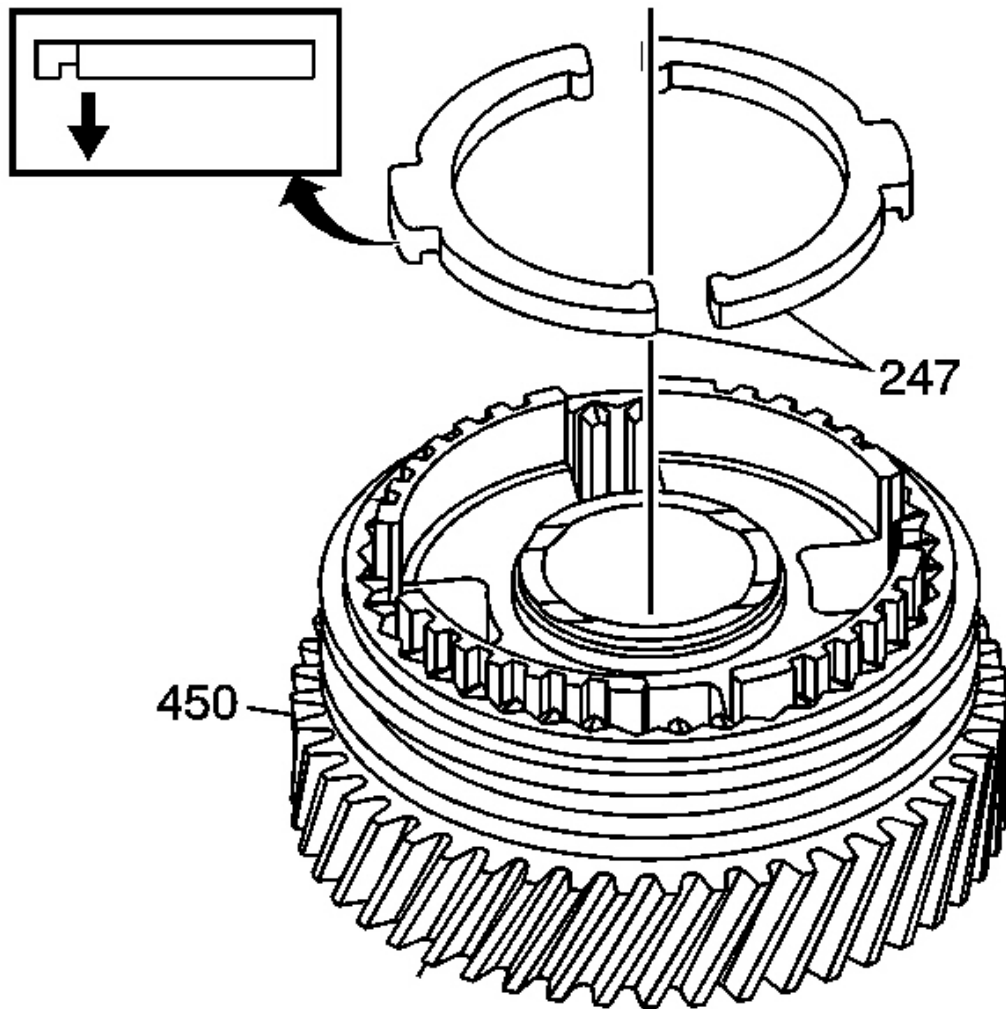

Fig. 190: Installing 5th Gear Synchronizer Inserts Into 5th Countershaft Gear
Courtesy of GENERAL MOTORS CORP.

2. Install the 5th gear synchronizer inserts (247) into the 5th countershaft gear (450) with the tab down, into the wide slot.

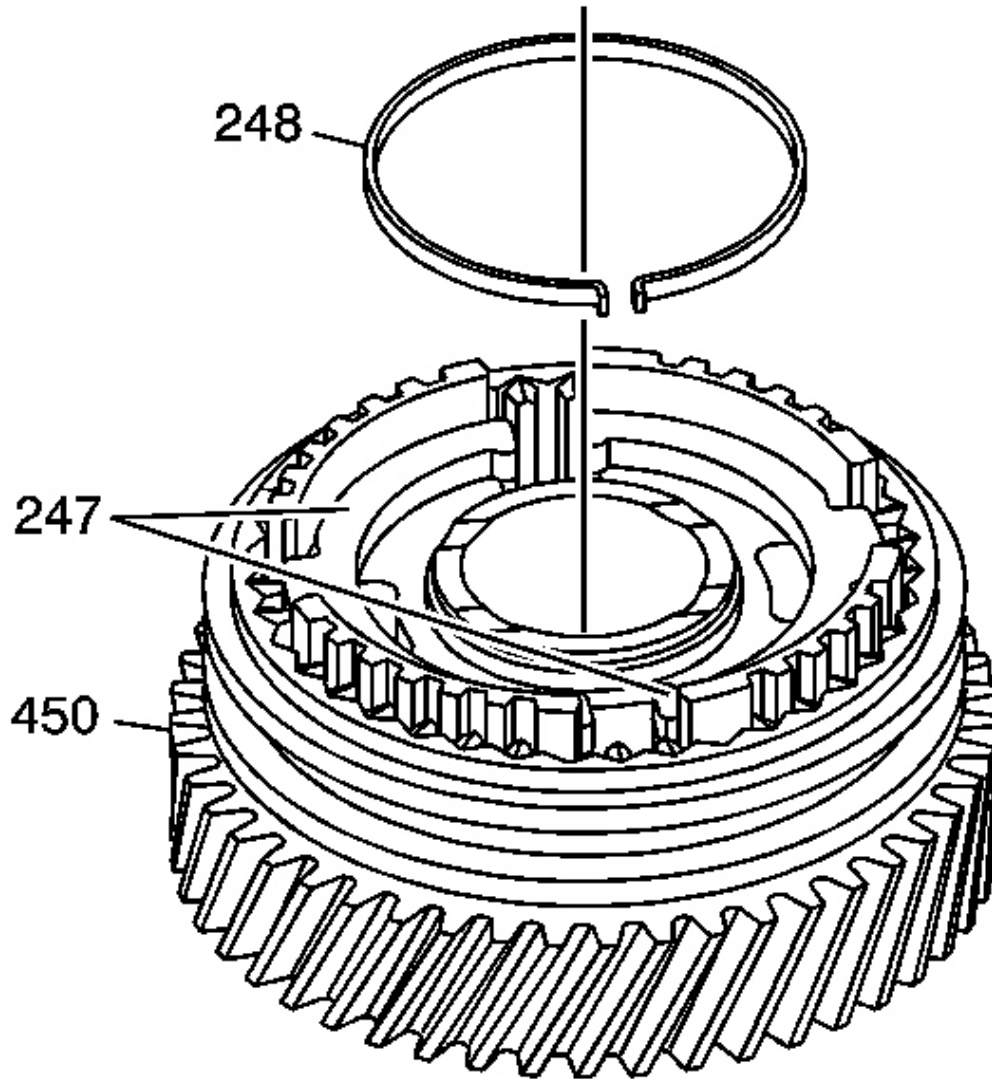

Fig. 191: Installing 5th Gear Synchronizer Spring
Courtesy of GENERAL MOTORS CORP.

3. Install the 5th gear synchronizer spring (248) between the inserts, with the locating tabs in the opening between the inserts.

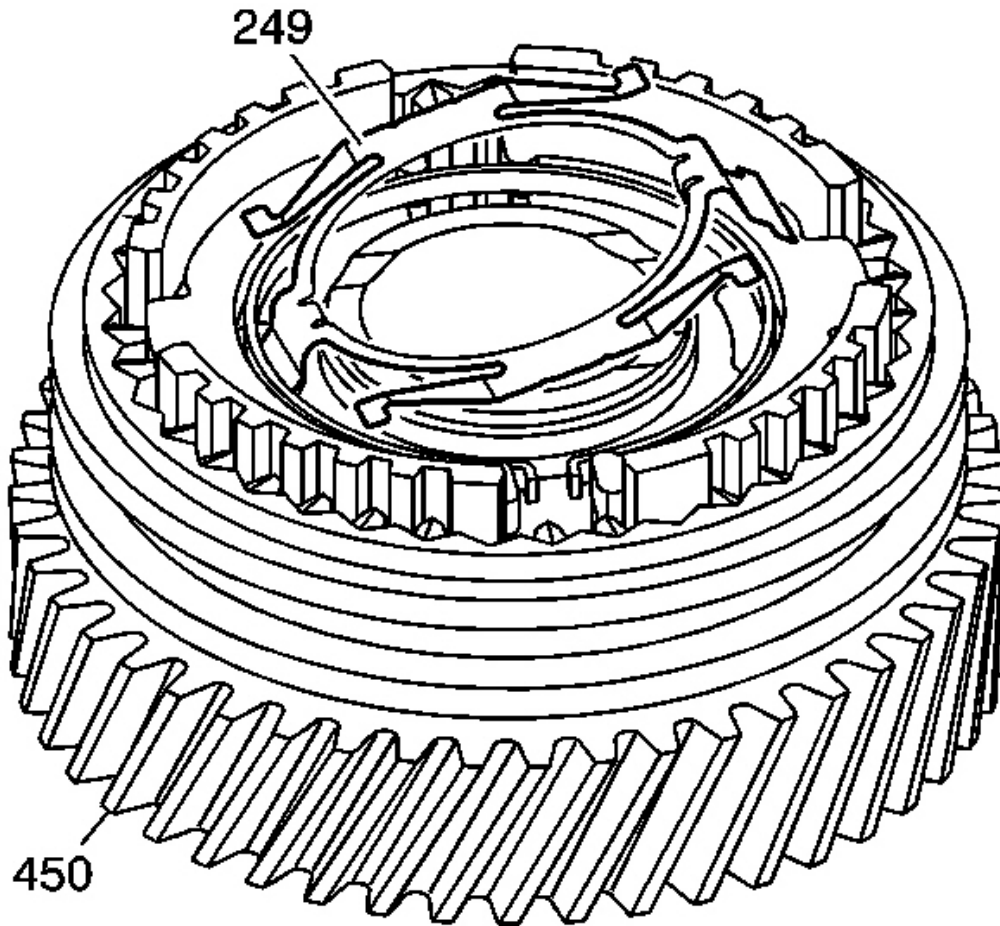

Fig. 192: Installing 5th/Reverse Synchronizer Spring
Courtesy of GENERAL MOTORS CORP.

4. Install the 5th/reverse synchronizer spring (249) retaining clips down, into the wide holes in the 5th countershaft gear (450).

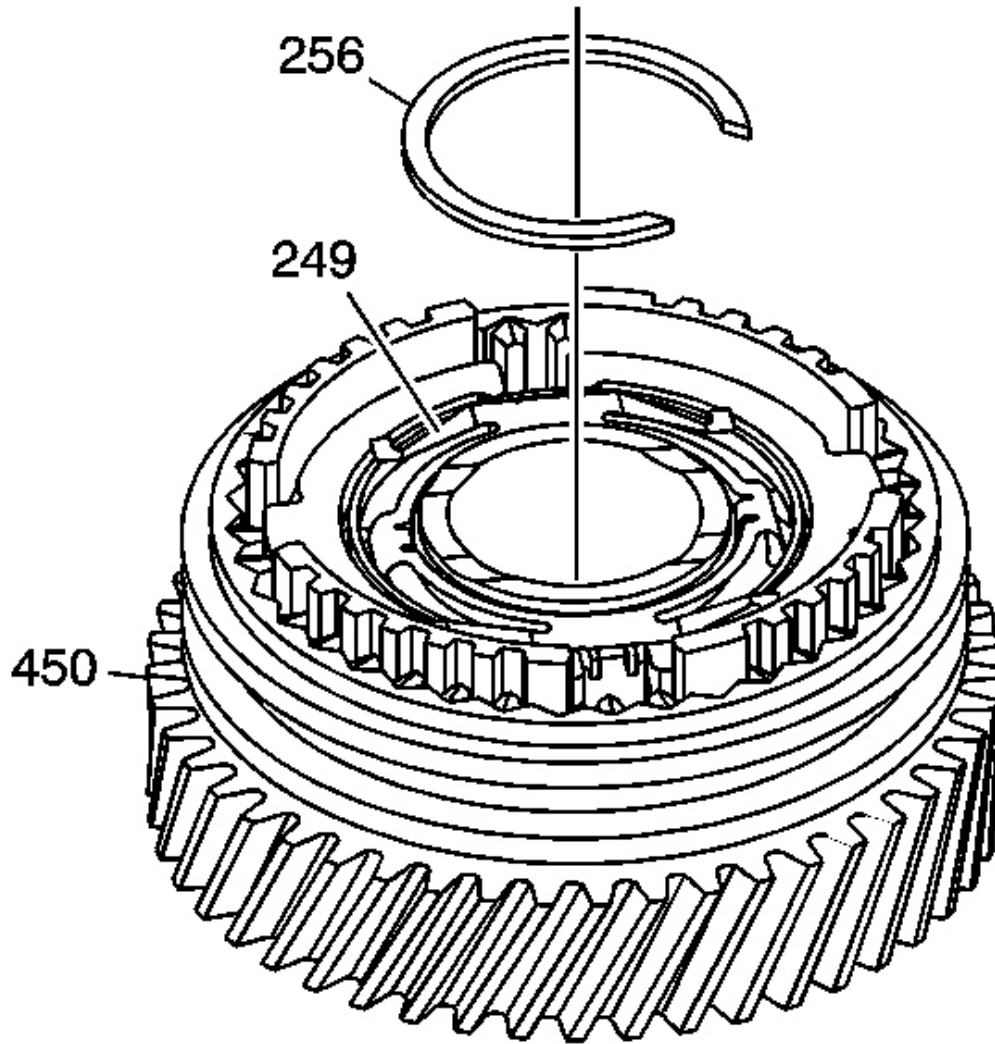

Fig. 193: Installing Retaining Ring Onto 5th Countershaft Gear
Courtesy of GENERAL MOTORS CORP.

5. Compress the 5th/reverse synchronizer spring (249) and install the retaining ring (256) onto the 5th countershaft gear (450).

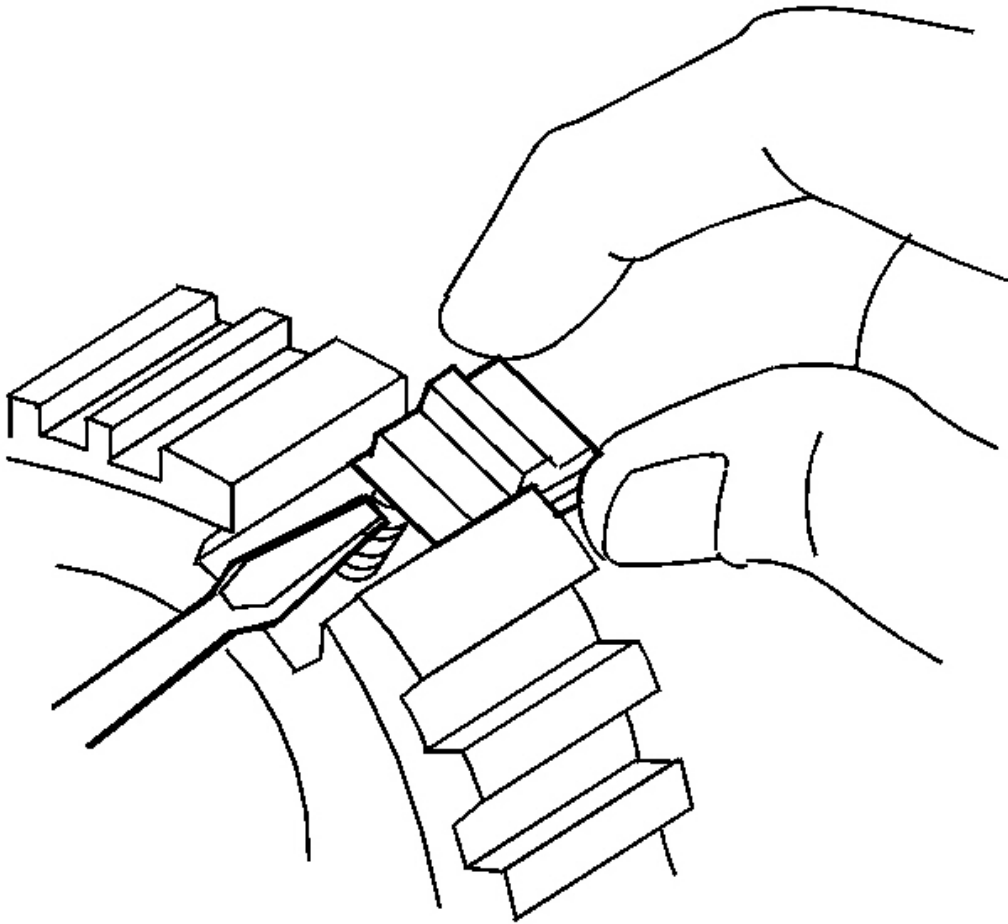

Fig. 194: View Of 1st/2nd Gear Synchronizer Hub Insert
Courtesy of GENERAL MOTORS CORP.

IMPORTANT: The 3rd/4th gear synchronizer hub cannot be used again after removal. Always install a new hub.

1. Install the synchronizer spring in the hole of a new 3rd/4th gear synchronizer hub.
2. Slide the insert in while pushing down on the spring.

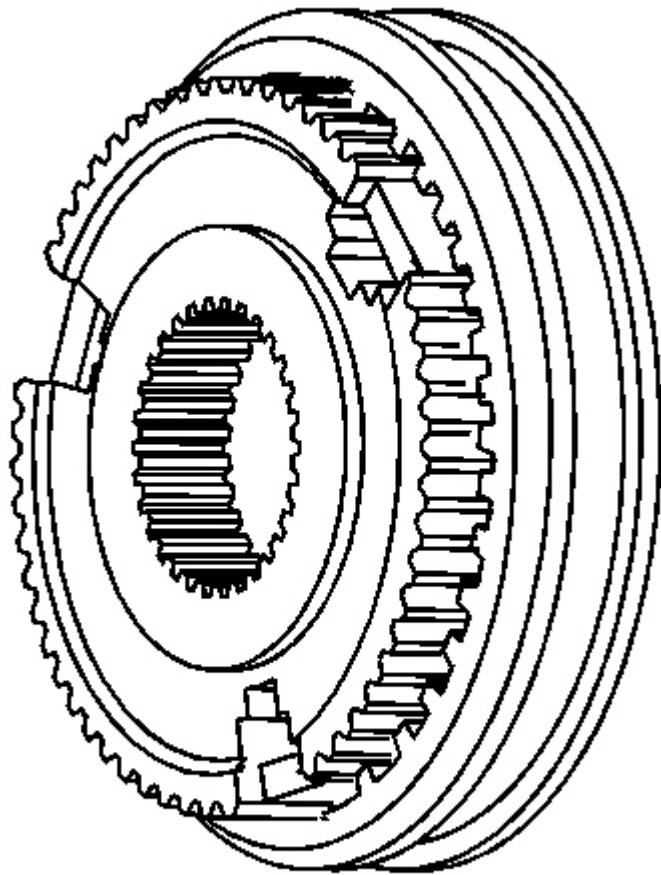

Fig. 195: Identifying 3rd/4th Synchronizer Sleeve
Courtesy of GENERAL MOTORS CORP.

3. Install the 3rd/4th synchronizer sleeve on the hub while pushing in the inserts.
 - The shoulder of the sleeve with the step goes forward, 4th gear side.
 - The smooth side of the hub, without the indents for synchronizer tabs, is the 4th gear side.
 - Align the inserts with the non-tooth areas of the sleeve.

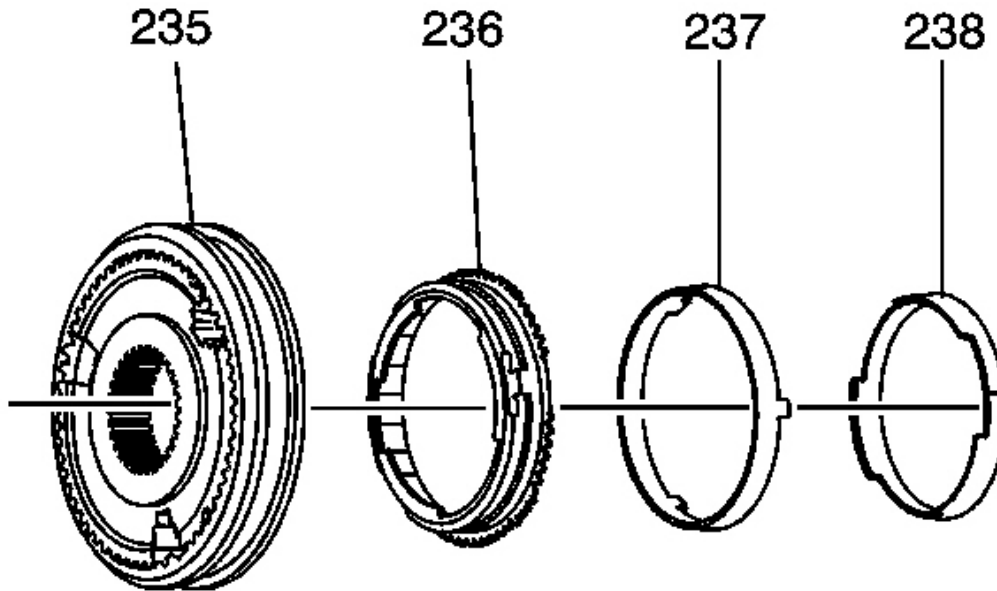

Fig. 196: Locating 3rd/4th Gear Synchronizer Hub Components
Courtesy of GENERAL MOTORS CORP.

4. Install the following components to the 3rd/4th gear synchronizer hub (235):

1. The 3rd gear outer blocking ring (236)

Ensure the tabs align in the hub.

2. The 3rd gear internal blocking ring (237)
3. The 3rd gear inner blocking ring (238)

Ensure the tabs align in the hub

The 4th gear blocking ring is installed with the input gear.

1st/2nd Gear Synchronizer

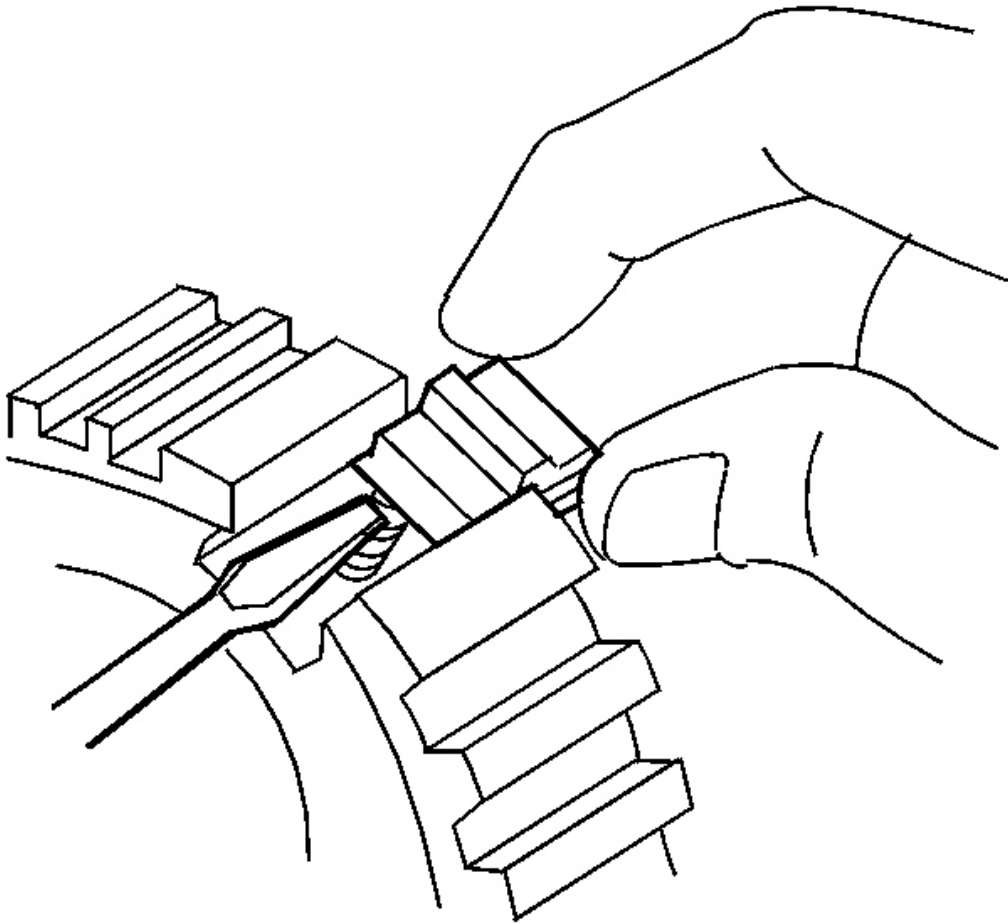

Fig. 197: View Of 1st/2nd Gear Synchronizer Hub Insert
Courtesy of GENERAL MOTORS CORP.

1. Install the synchronizer spring in the hole of the 1st/2nd gear synchronizer hub.
2. Slide the insert in while pushing down on the spring.

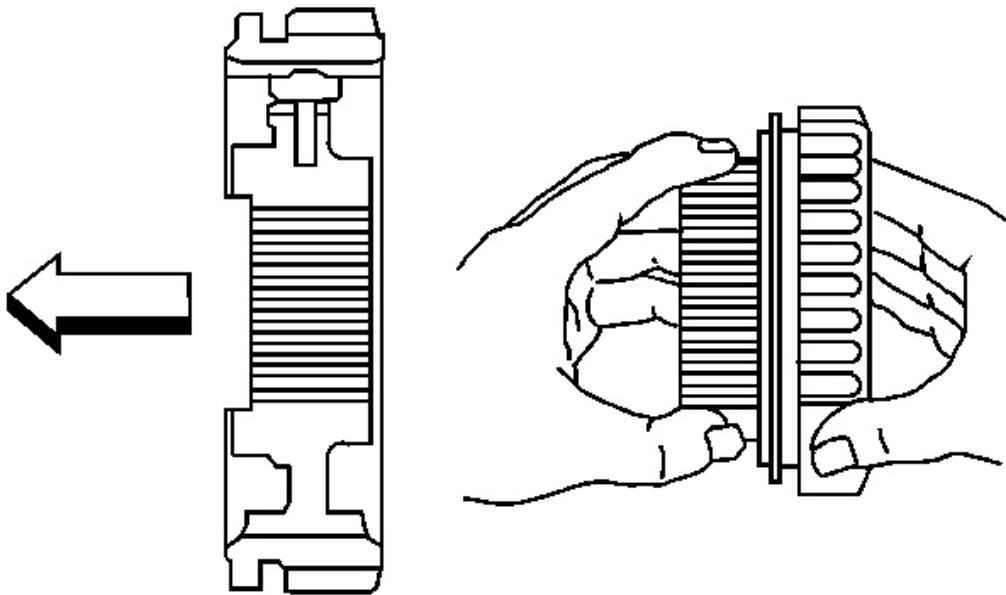

Fig. 198: Installing Reverse Gear Onto Hub
Courtesy of GENERAL MOTORS CORP.

3. Install the reverse gear on the hub while pushing in the inserts.
 - The forward, 2nd gear, side of the reverse gear has the shift fork groove.
 - The 2nd gear side of the hub has the internal splines indented from the thrust surface.
 - Align the inserts with the non-tooth areas of the sleeve.

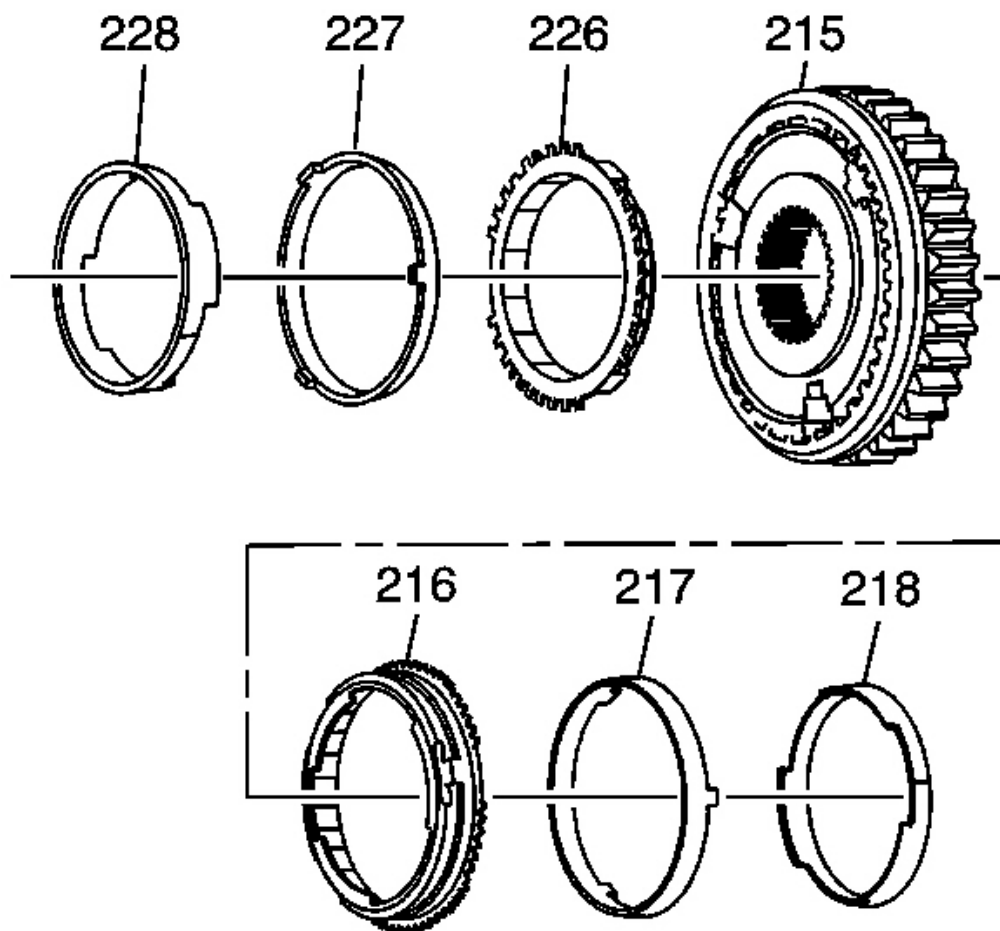

Fig. 199: Identifying 1st/2nd Gear Synchronizer Hub Components
Courtesy of GENERAL MOTORS CORP.

IMPORTANT: When you service the synchronizers, retain them in the order that they are removed. Keep the synchronizer components together and mark to identify the correct location.

4. Install the following components to the 1st/2nd gear synchronizer hub (215). Ensure the tabs on the rings are aligned with the notches in the hub.
 - The 2nd gear inner blocking ring (228)
 - The 2nd gear internal blocking ring (227)

- The 2nd gear outer blocking ring (226)
- The 1st gear outer blocking ring (216)
- The 1st gear internal blocking ring (217)
- The 1st gear inner blocking ring (218)

TRANSMISSION EXTENSION ASSEMBLY

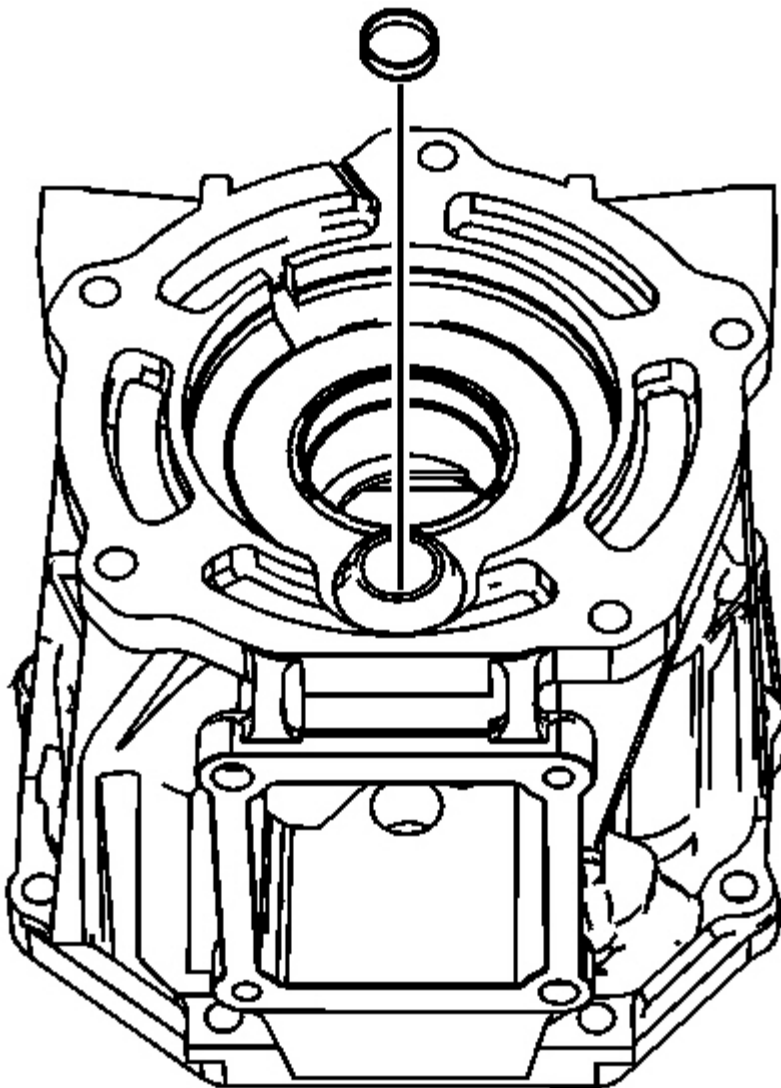

Fig. 200: View Of Shift Control Shaft Plug
Courtesy of GENERAL MOTORS CORP.

1. For the 4WD transmission, install the shift control shaft plug.

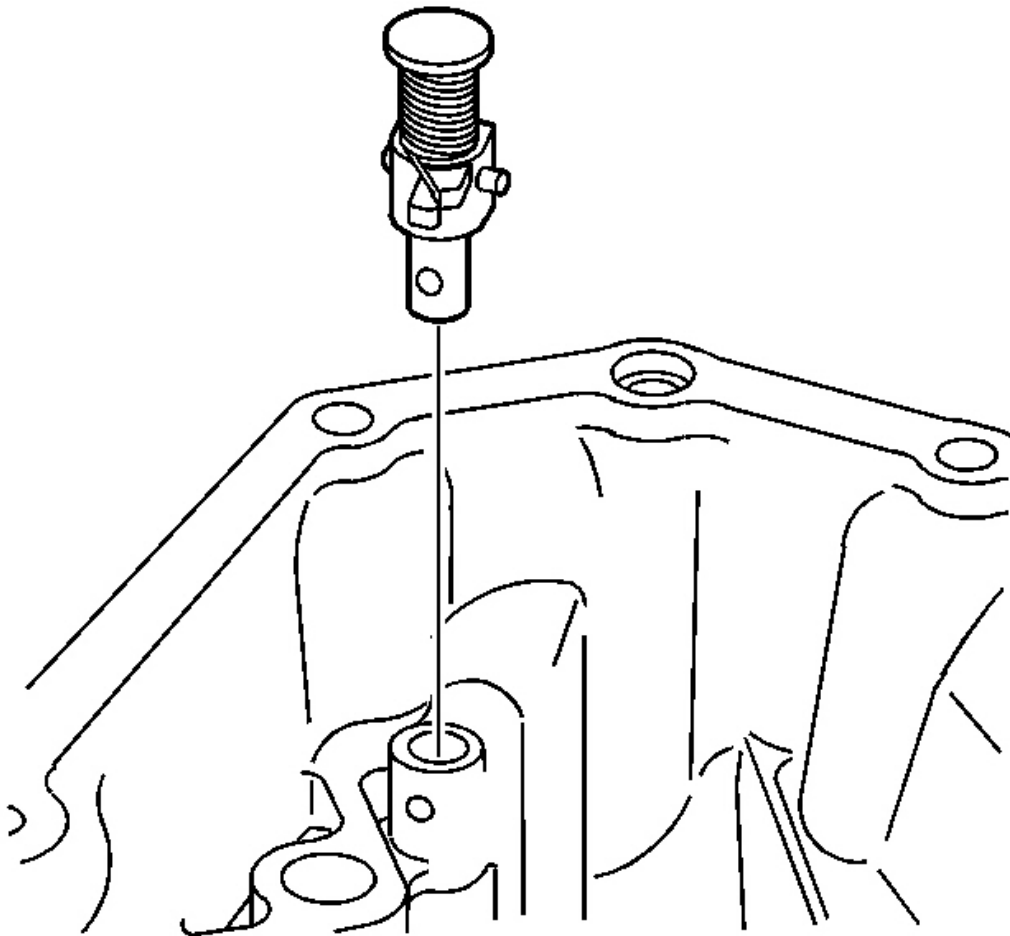

Fig. 201: Locating Reverse Control Lever Restrictor
Courtesy of GENERAL MOTORS CORP.

2. If removed, install the reverse control lever restrictor.

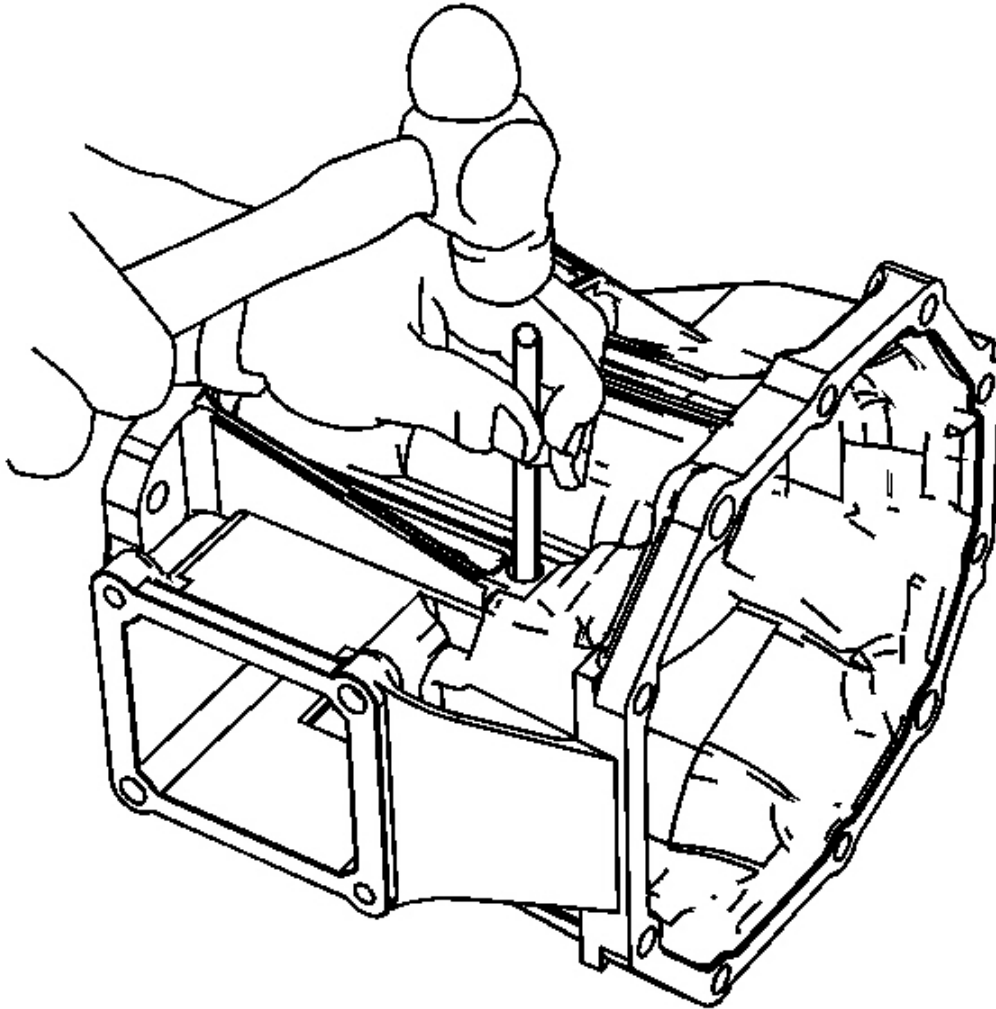

Fig. 202: Removing/Installing Reverse Control Lever Restrictor Roll Pin
Courtesy of GENERAL MOTORS CORP.

3. Install a new reverse control lever restrictor roll pin.

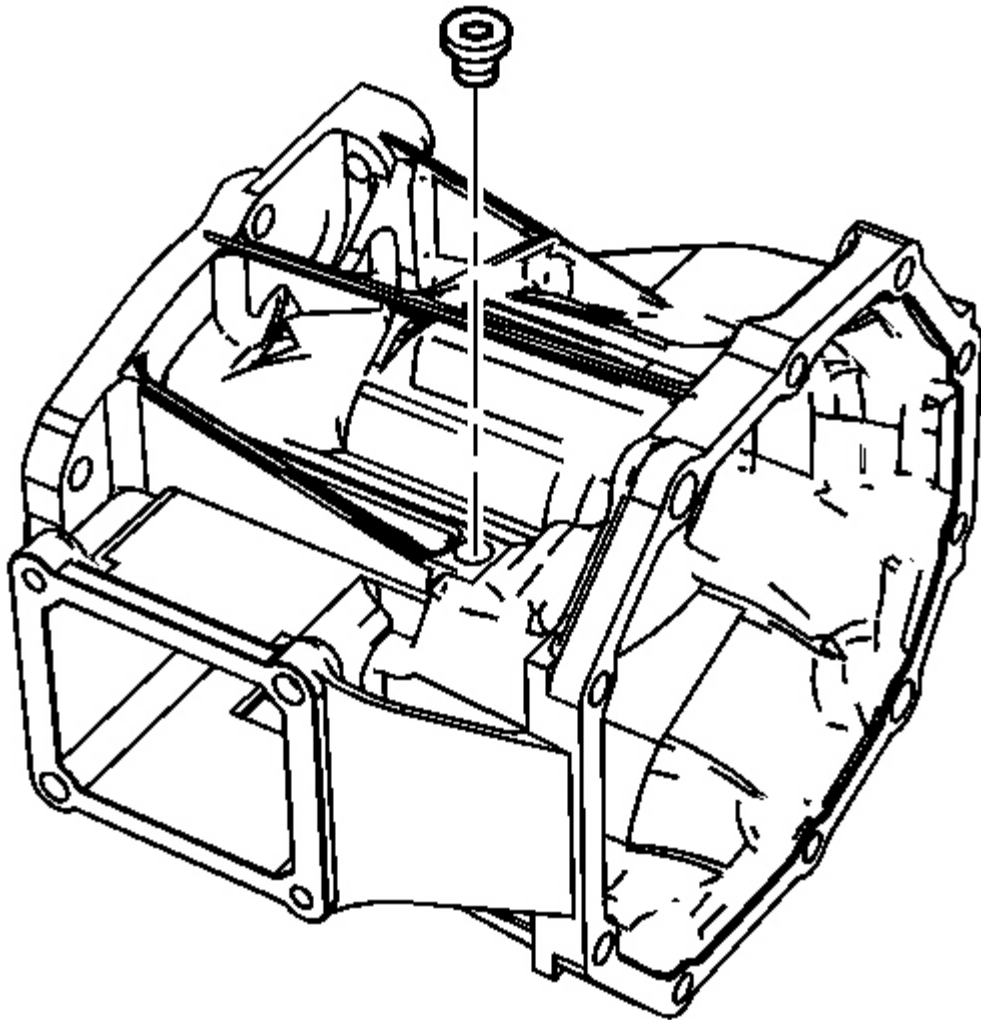

Fig. 203: View Of Reverse Restrictor Pin Plug
Courtesy of GENERAL MOTORS CORP.

NOTE: Refer to Fastener Notice .

4. Install a new reverse restrictor pin plug.

Tighten: Tighten the reverse restrictor pin plug to 19 N.m (14 lb ft).

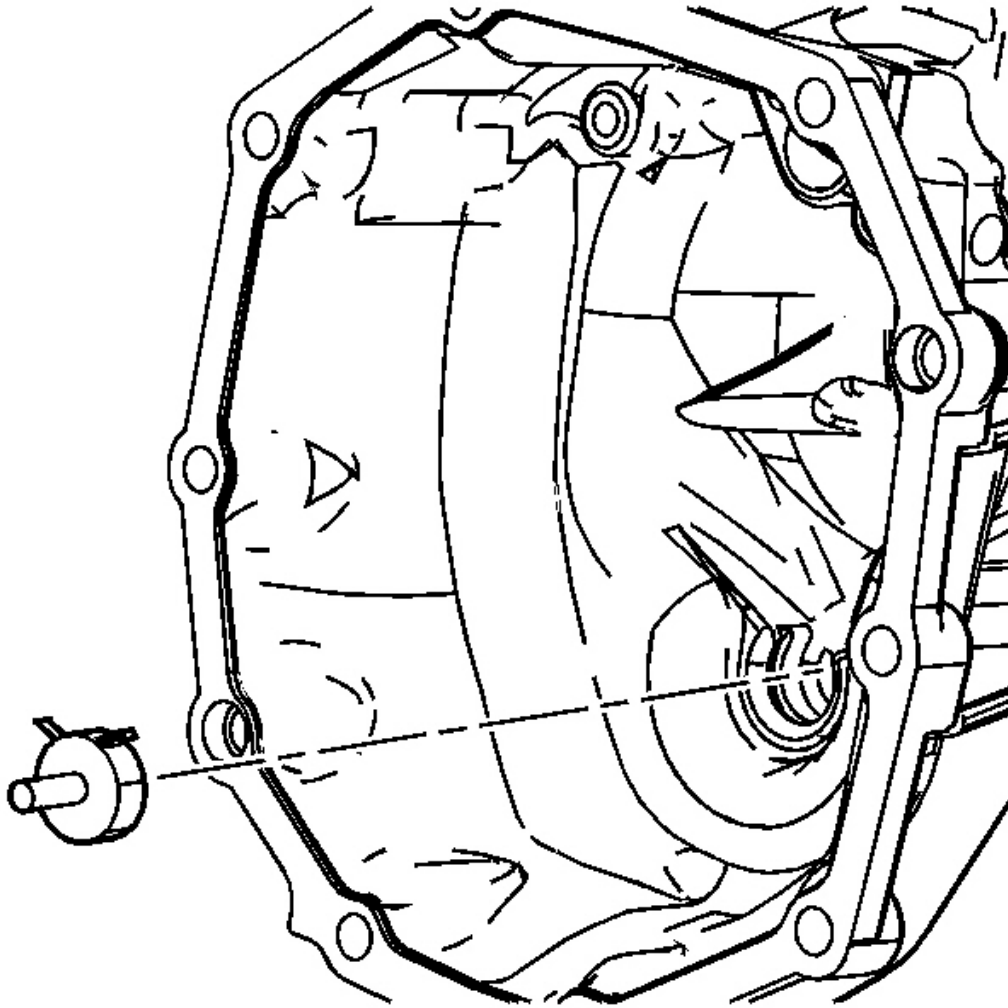

Fig. 204: Locating Oil Receiver
Courtesy of GENERAL MOTORS CORP.

5. Install the oil receiver.

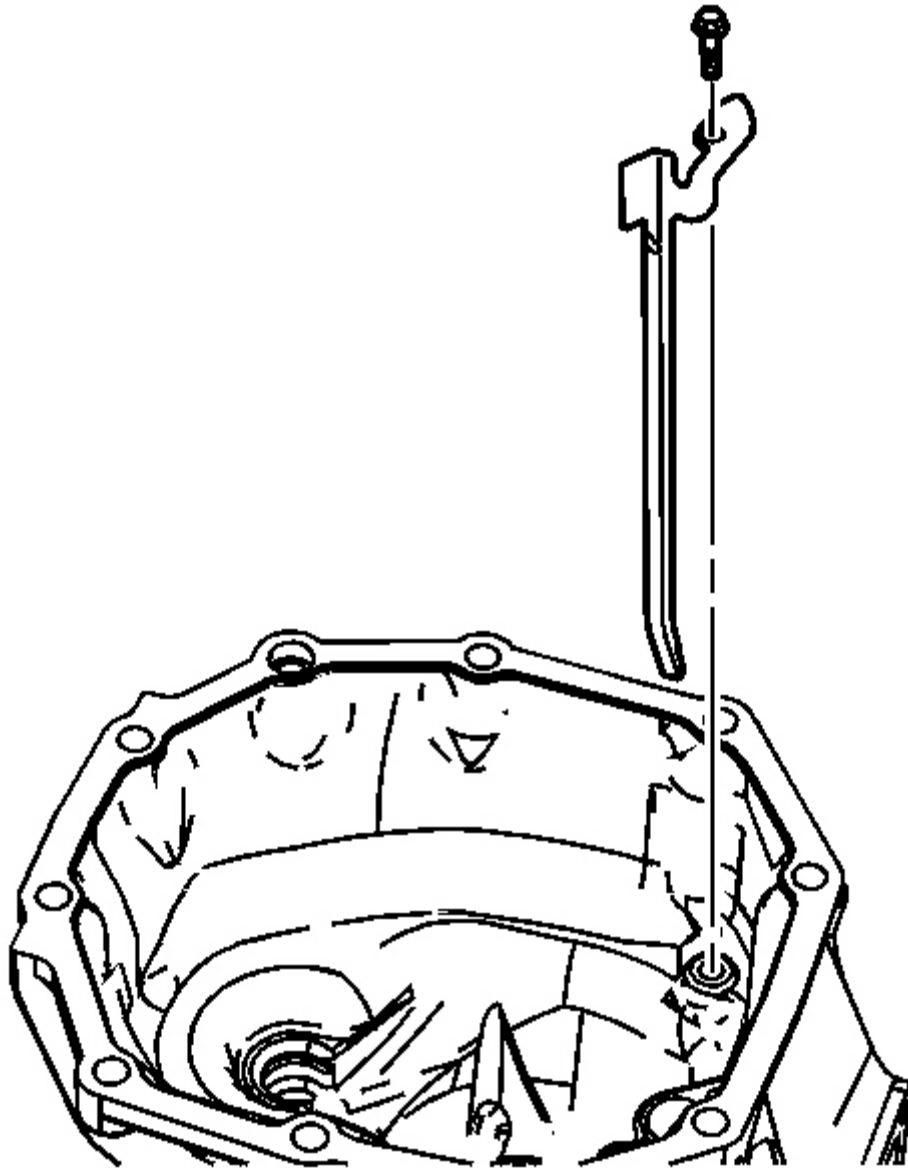

Fig. 205: Identifying Oil Trough & Mounting Bolt
Courtesy of GENERAL MOTORS CORP.

6. If RWD, install the oil trough.
7. Install the oil trough bolt.

Tighten: Tighten the oil trough bolt to 11 N.m (8 lb ft).

TRANSMISSION CASE ASSEMBLE

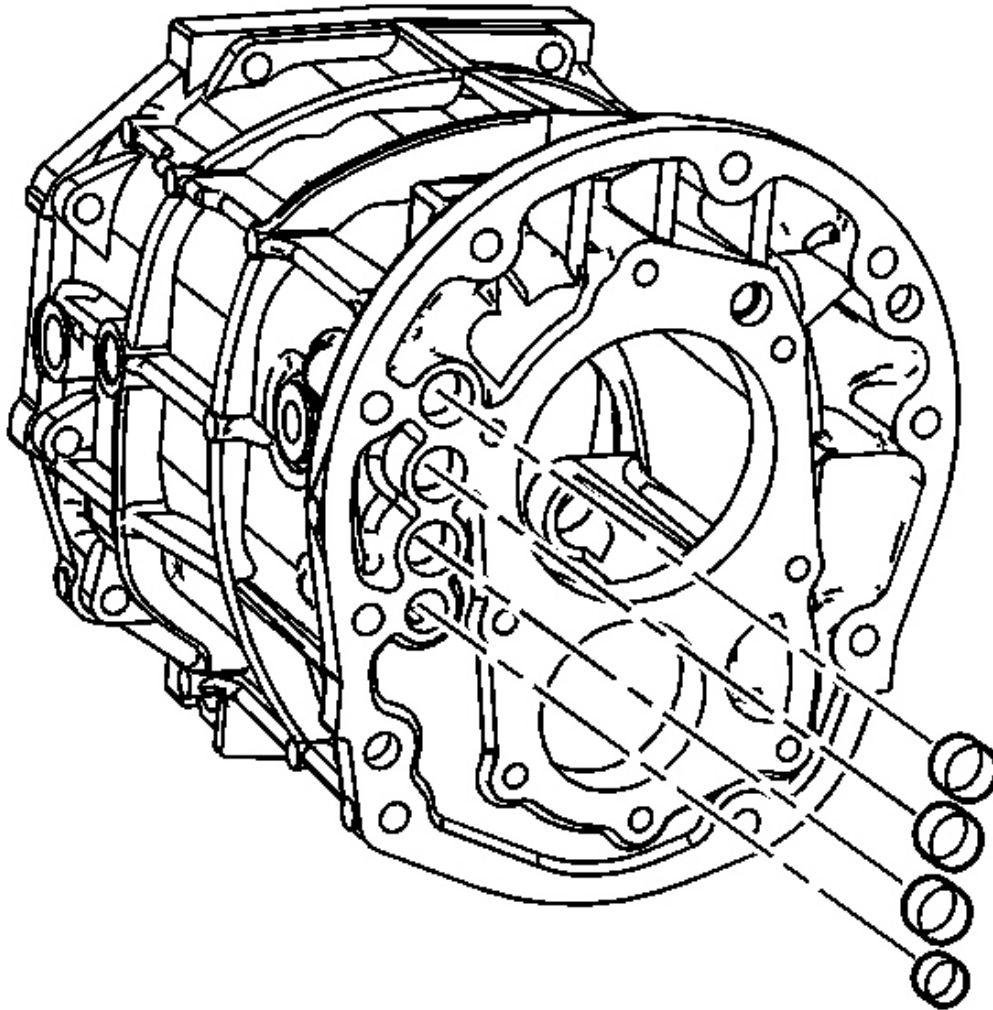

Fig. 206: Locating Shift Shaft Plugs In Transmission Front Case
Courtesy of GENERAL MOTORS CORP.

1. If removed, apply threadlocker GM P/N 12345382 (Canadian P/N 10953489) to the shift shaft plugs.
2. Using a suitable driver, install the shift shaft plugs into the transmission front case.

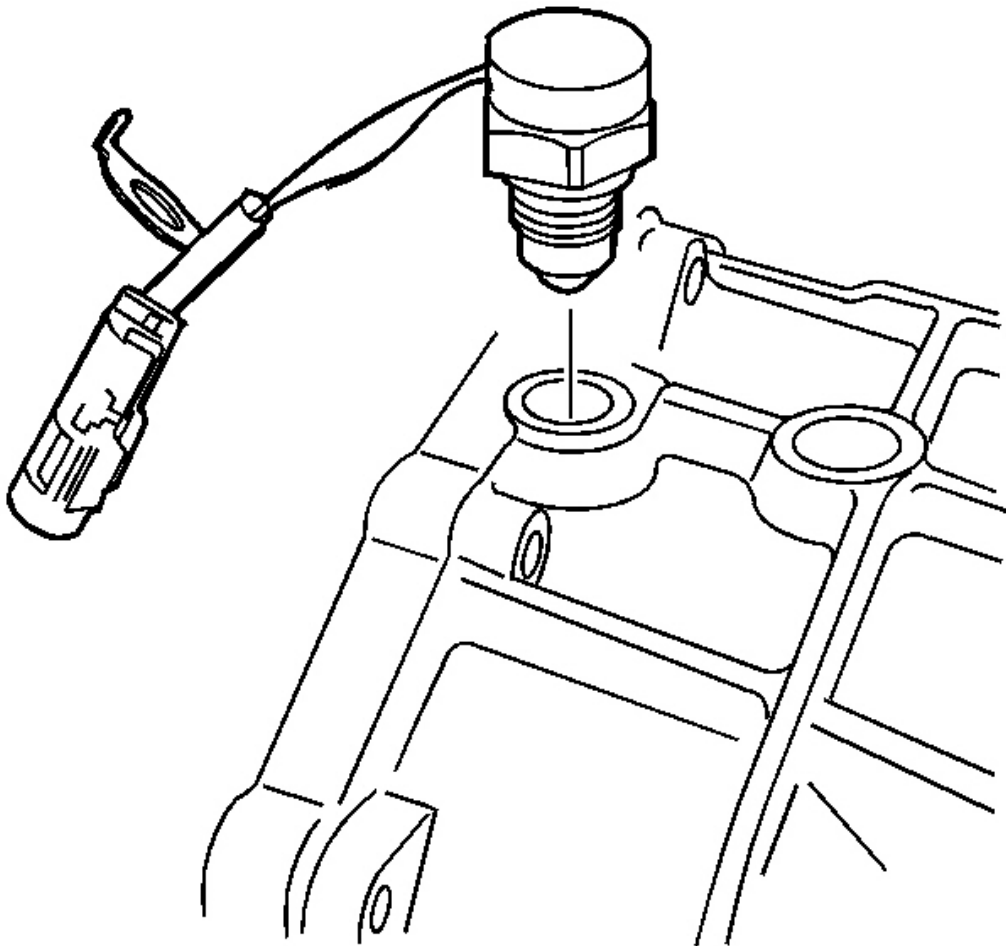

Fig. 207: View Of Backup Lamp Switch
Courtesy of GENERAL MOTORS CORP.

NOTE: Refer to Fastener Notice .

3. Install the backup lamp switch, with the gasket, into the transmission case.

Tighten: Tighten the backup lamp switch to 44 N.m (32 lb ft).

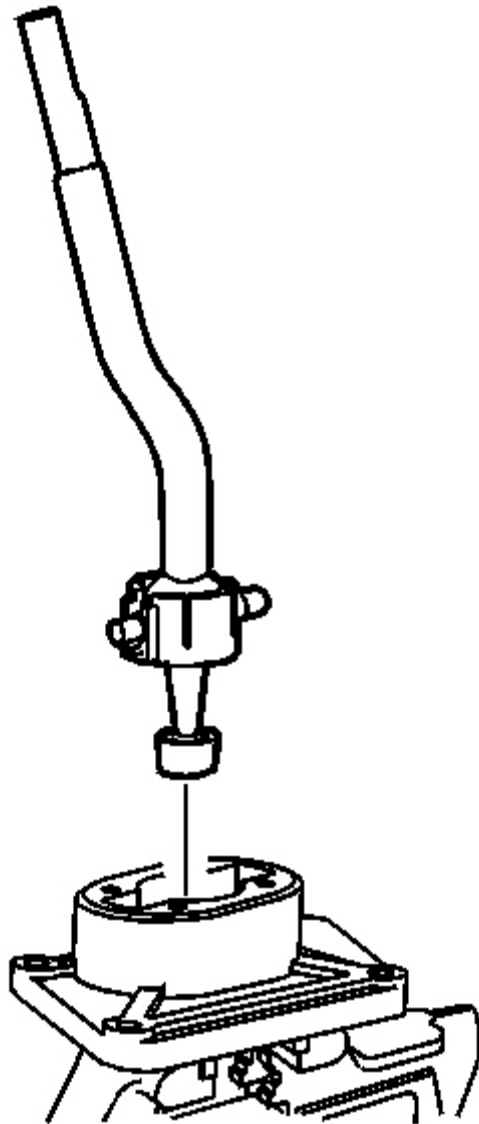

Fig. 208: Identifying Shift Control Lever Assembly
Courtesy of GENERAL MOTORS CORP.

1. Lubricate the shift lever plungers and the lever spring seat surface of the shift control housing with transmission fluid.
2. Install the shift control lever assembly into the shift control housing.

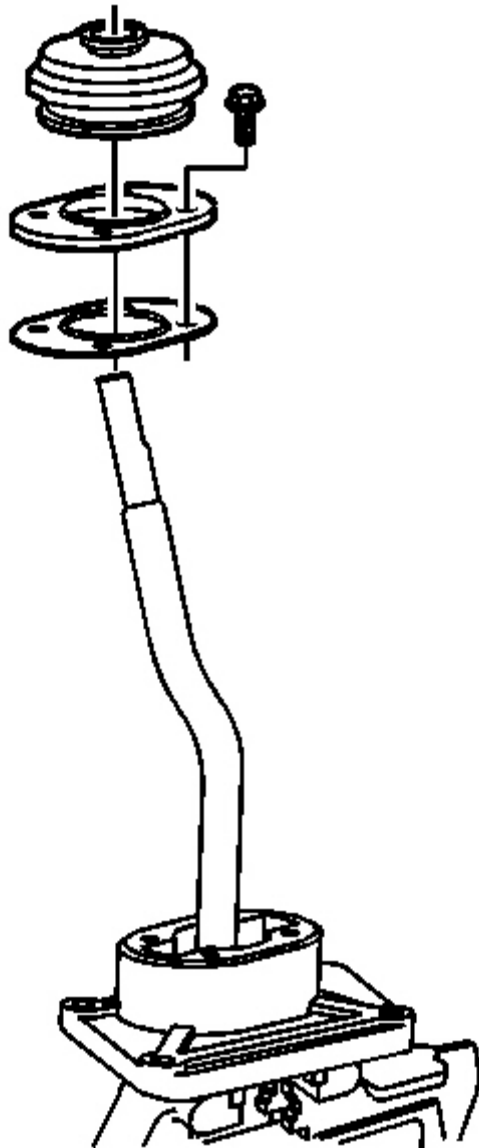

Fig. 209: View Of Shift Control Lever Retainer & Retaining Bolts
Courtesy of GENERAL MOTORS CORP.

IMPORTANT: Do not use a petroleum base or silicon lubricate on the shift control lever seals or boots. If a lubricant is required, use a

water base liquid soap.

3. Install the shift control lever shaft boot in the retainer.
4. Install a control lever housing gasket to the housing.
5. Install the shift control lever retainer.

NOTE: Refer to Fastener Notice .

6. Install the shift control lever retainer bolts.

Tighten: Tighten the retainer bolts to 20 N.m (14 lb ft).

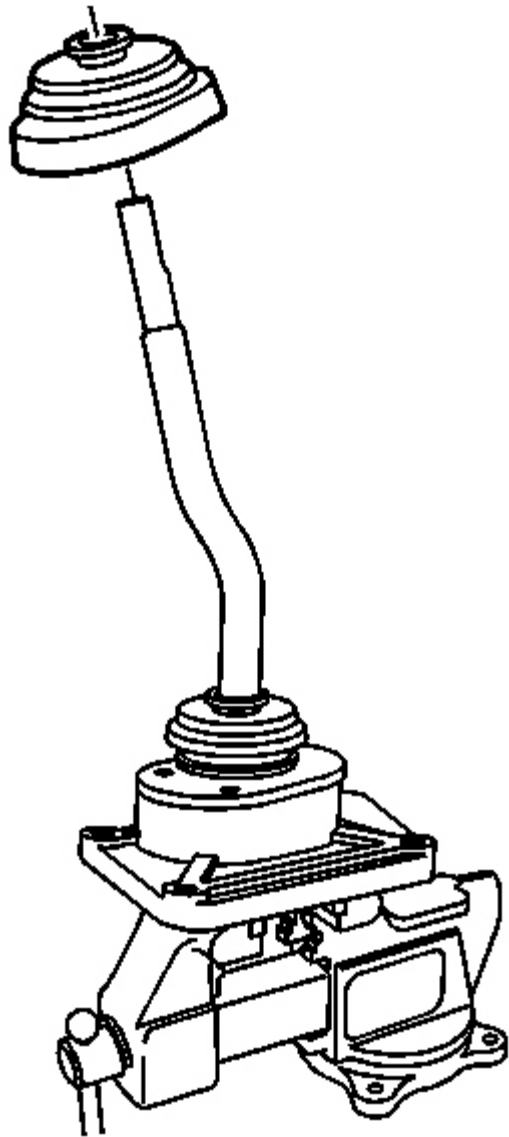

Fig. 210: Identifying Control Lever Boot
Courtesy of GENERAL MOTORS CORP.

7. Install the control lever boot.

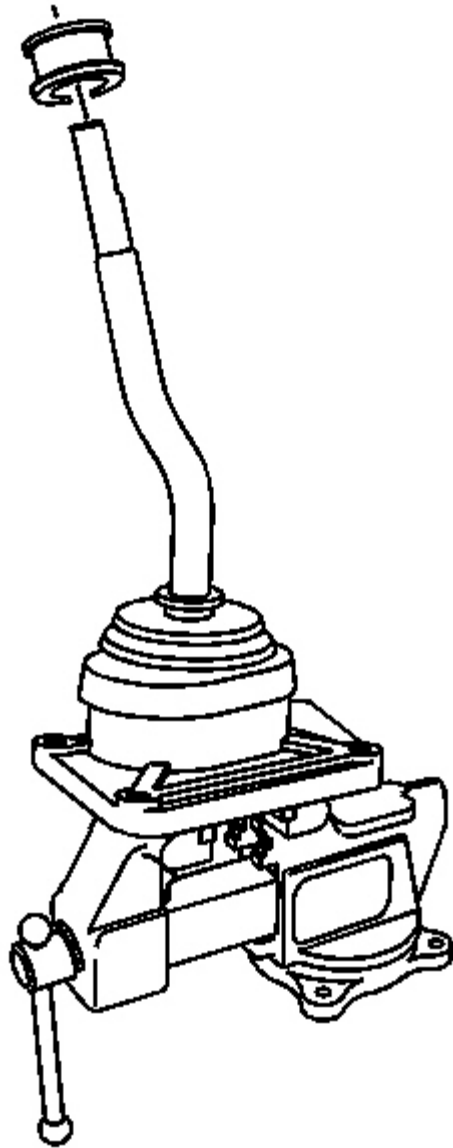

Fig. 211: Locating Shift Control Lever Shaft Seal
Courtesy of GENERAL MOTORS CORP.

8. Install the shift control lever shaft seal.

Tools Required

J 22912-B Split-Plate Bearing Puller

Assembly Procedure

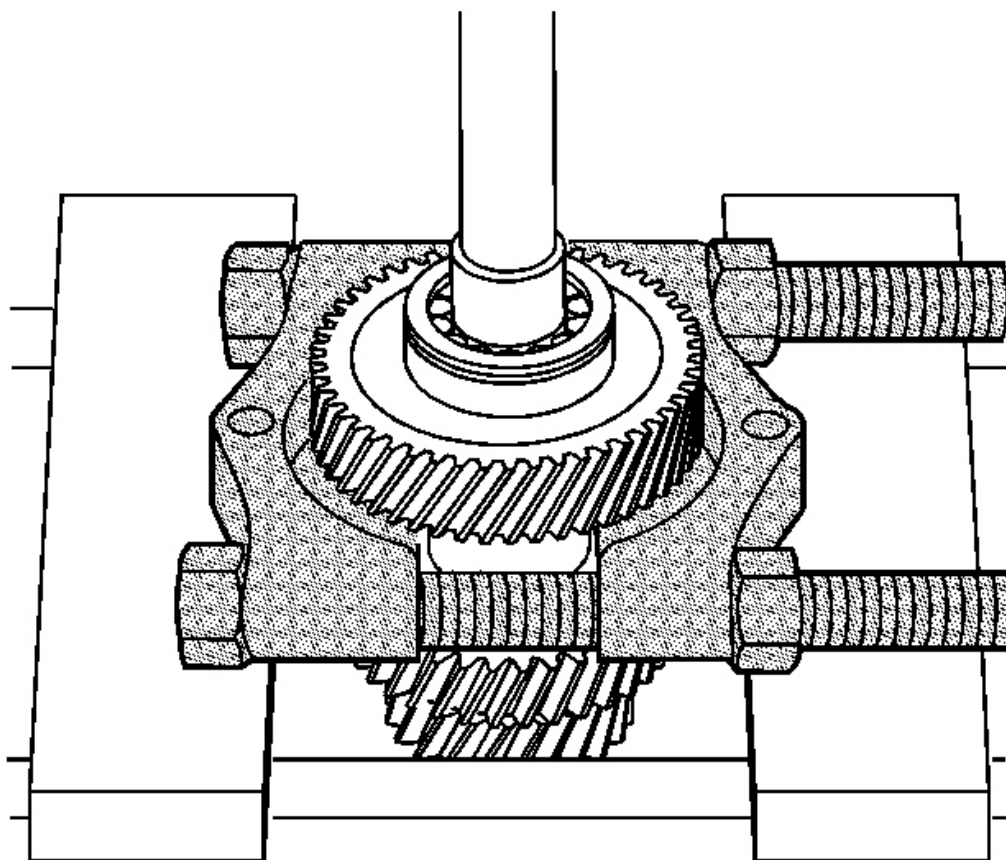

Fig. 212: Installing New Front Bearing On Countershaft Using J 22912-01
Courtesy of GENERAL MOTORS CORP.

1. Using a hydraulic press and **J 22912-B** under the gear, install a new front bearing on the countershaft.
 1. Install the bearing collar race on the countershaft.
 2. Install the bearing assembly with the retaining ring groove forward.
 3. Install the bearing inner race using a suitable press tube.

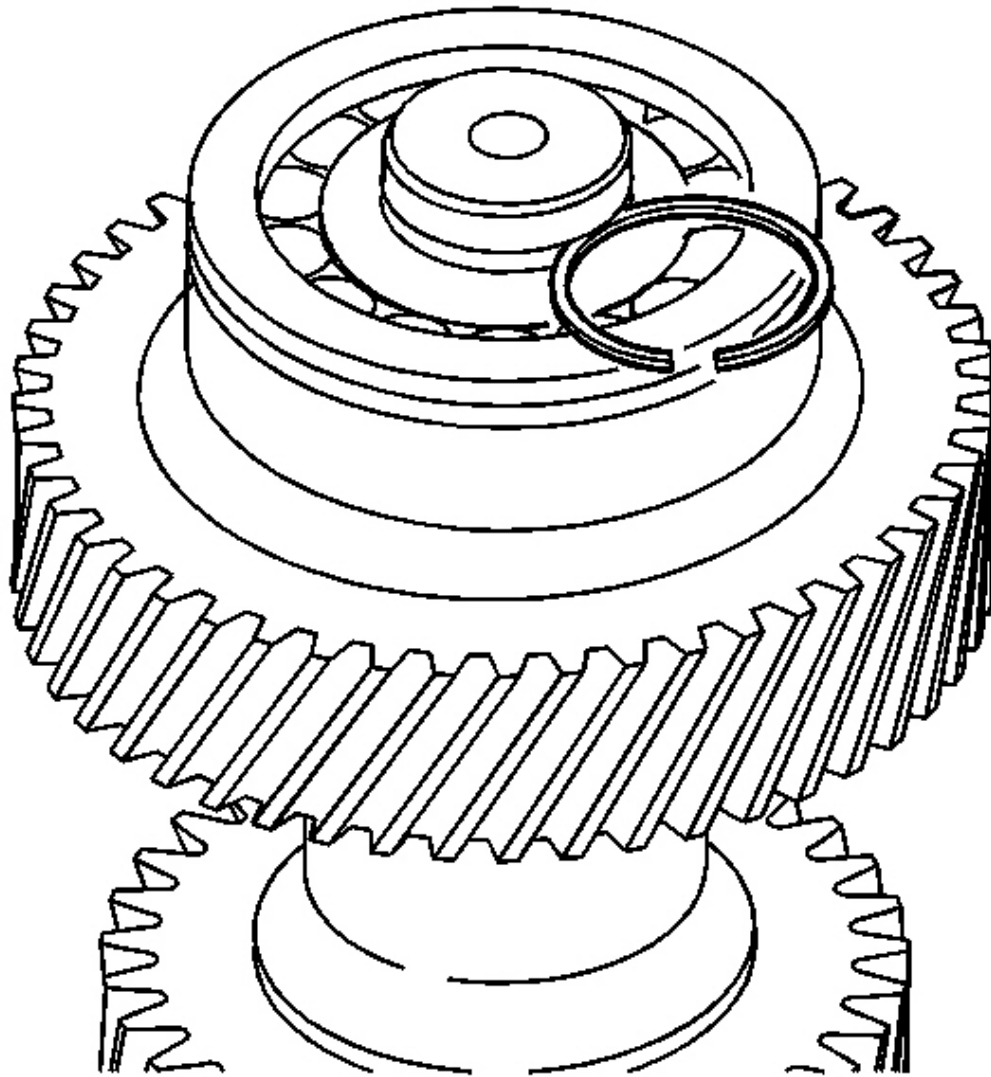

Fig. 213: Identifying Countershaft Front Bearing Retaining Ring
Courtesy of GENERAL MOTORS CORP.

IMPORTANT: The retaining ring is a select fit. Always install a new retaining ring.

2. Select the maximum thickness retaining ring for the countershaft front bearing, that will fit in the groove. Refer to **Countershaft Front Bearing Retaining Ring Specifications**.

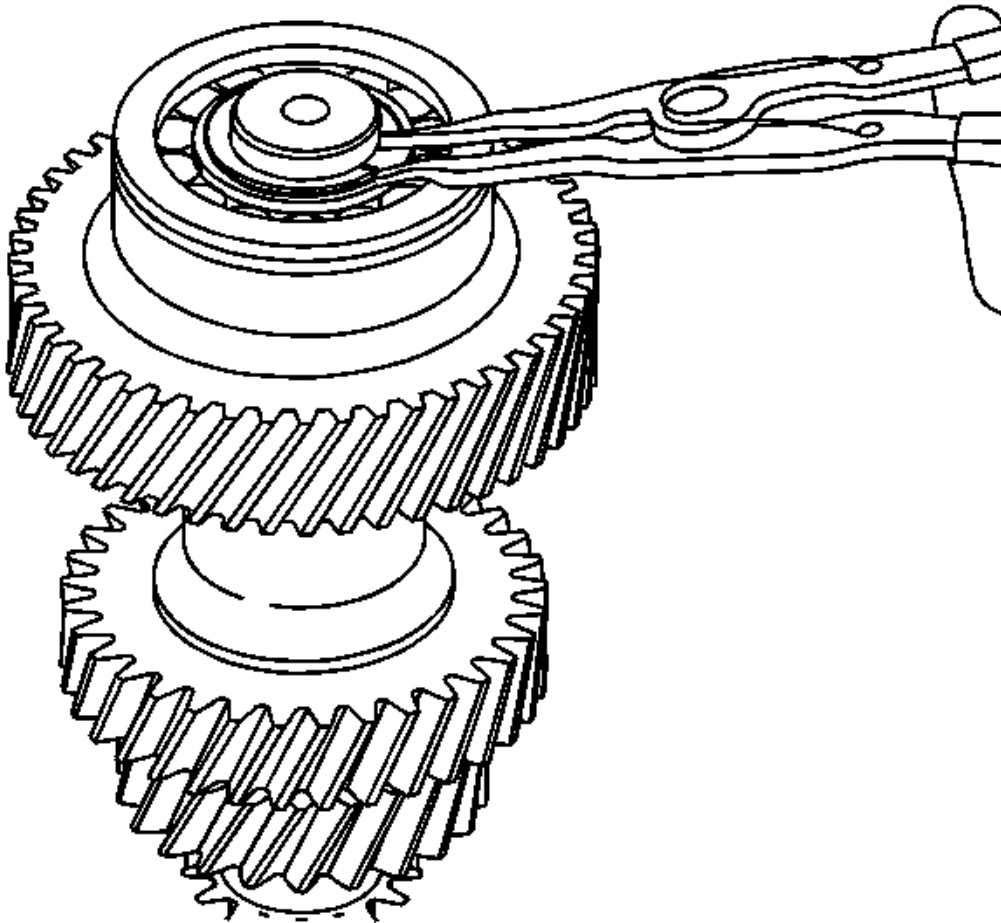

Fig. 214: Locating Countershaft Front Bearing Retaining Ring
Courtesy of GENERAL MOTORS CORP.

3. Install the countershaft front bearing retaining ring.

INPUT SHAFT ASSEMBLE

Tools Required

- **J 36850** Transjel Lubricant
- **J 44339** Reverse Synchronizer Installer. See **Special Tools**.

Assembly Procedure

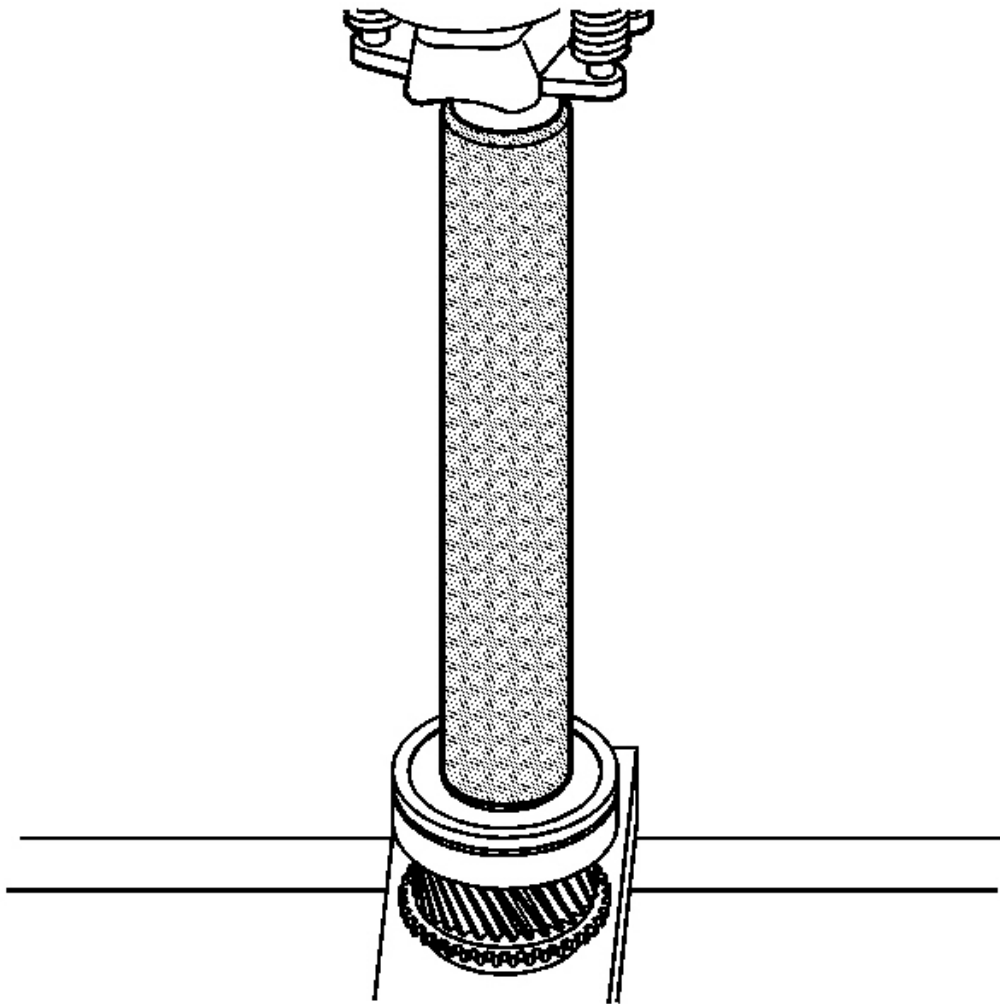

Fig. 215: Installing Input Shaft Bearing Using J 44339
Courtesy of GENERAL MOTORS CORP.

1. Install a new input shaft bearing on the input shaft. The bearing retaining ring groove goes forward.
2. Using a hydraulic press and **J 44339** , install the input shaft bearing in position. See **Special Tools**.

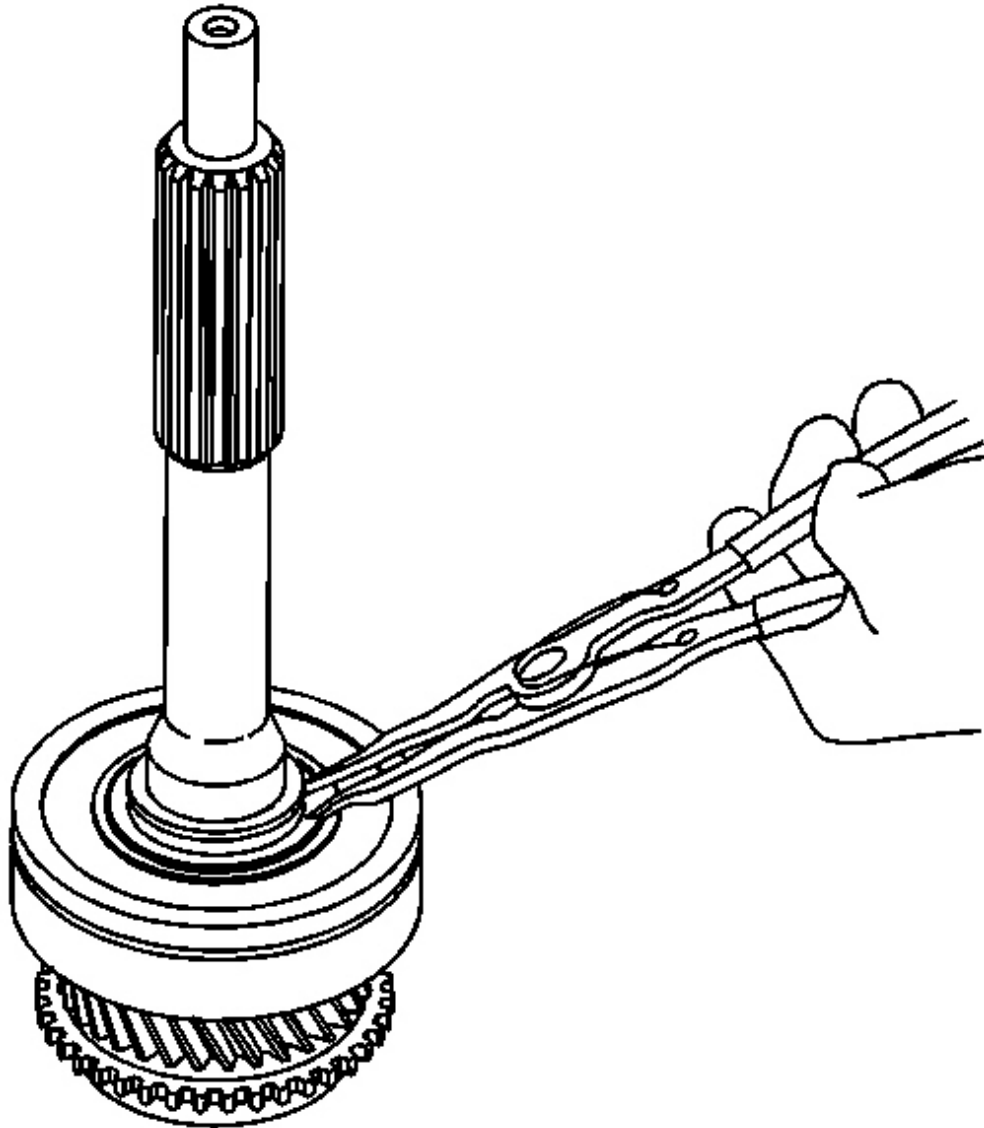

Fig. 216: Identifying Input Shaft Bearing Retaining Ring
Courtesy of GENERAL MOTORS CORP.

IMPORTANT: The retaining ring is a select fit. Always install a new retaining ring.

3. Select the maximum thickness retaining ring for the input shaft bearing, that will fit in the groove. Refer to **Input Shaft Bearing Retaining Ring Specifications**.
4. Install the input shaft bearing retaining ring.

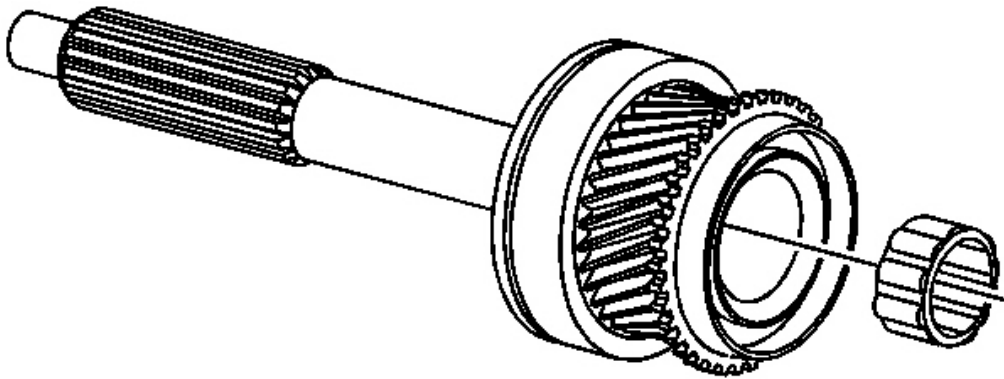

Fig. 217: Locating Output Front Support Bearing
Courtesy of GENERAL MOTORS CORP.

5. Install the output front support bearing into the input shaft.
6. Fill the bearing with **J 36850** .

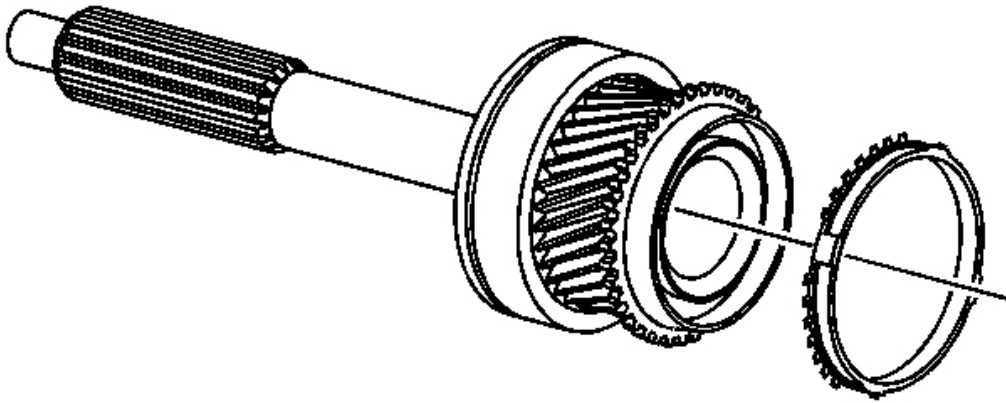

Fig. 218: View Of 4th Gear Blocking Ring
Courtesy of GENERAL MOTORS CORP.

7. Install the 4th gear blocking ring onto the input shaft.

OUTPUT SHAFT ASSEMBLE

Tools Required

- **J 6133-A** Bearing Race Installer. See Special Tools.
- **J 8001-3** Dial Indicator
- **J 26900-12** Dial Indicator - 1-10 mm. See Special Tools.
- **J 26900-13** Magnetic Indicator Base
- **J 44340** Bearing Installer. See Special Tools.

Assembly Procedure

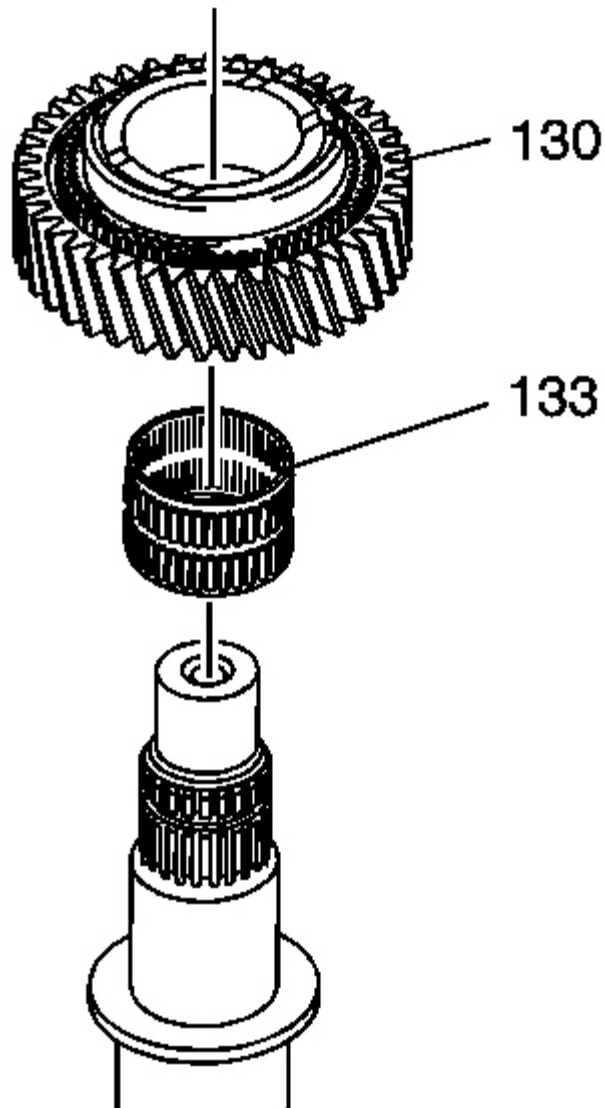

Fig. 219: Identifying 3rd Gear Bearing & 3rd Gear
Courtesy of GENERAL MOTORS CORP.

IMPORTANT:

- Lubricate all bearings with transmission fluid during assembly.
- The following steps apply to both the 4WD and the RWD

transmission, except where noted.

1. Install the 3rd gear bearing (130) and the 3rd gear (133) on the front of the output shaft.

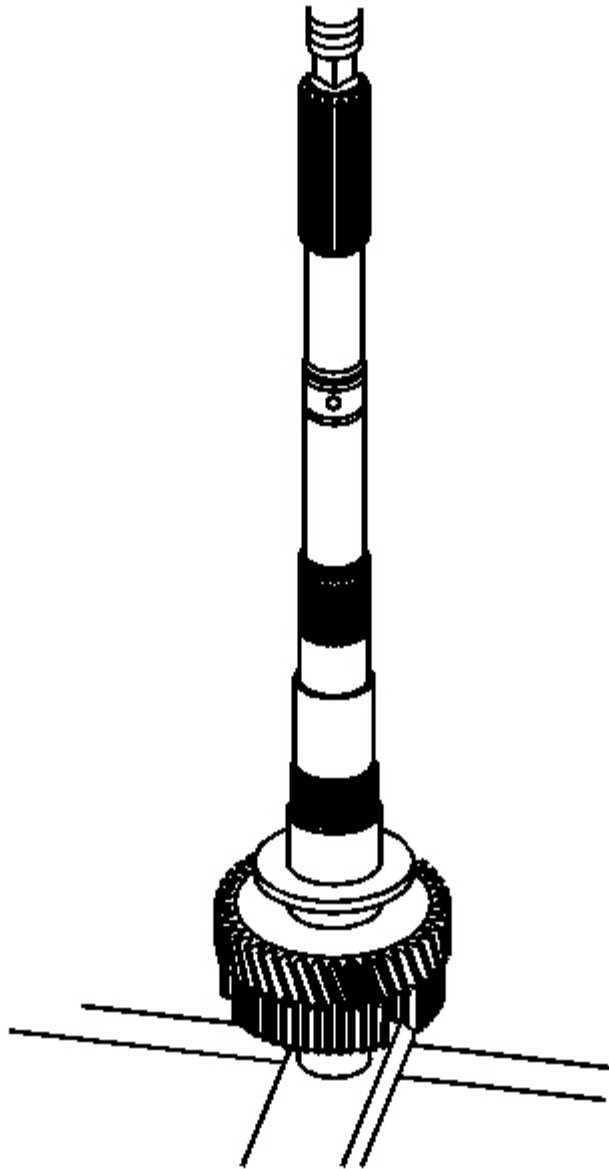

Fig. 220: Locating Output Shaft

Courtesy of GENERAL MOTORS CORP.

2. Remove the sleeve from the 3rd/4th synchronizer assembly.
3. Position the synchronizer hub and 3rd gear blocking rings on the output shaft. The smooth side of the hub goes forward, the 4th gear side.
4. Using a hydraulic press, install a new 3rd/4th synchronizer hub on the output shaft.
 - Support the synchronizer hub on the center flange with a suitable tube.
 - Align the blocking rings with the hub and the 3rd gear while pressing.

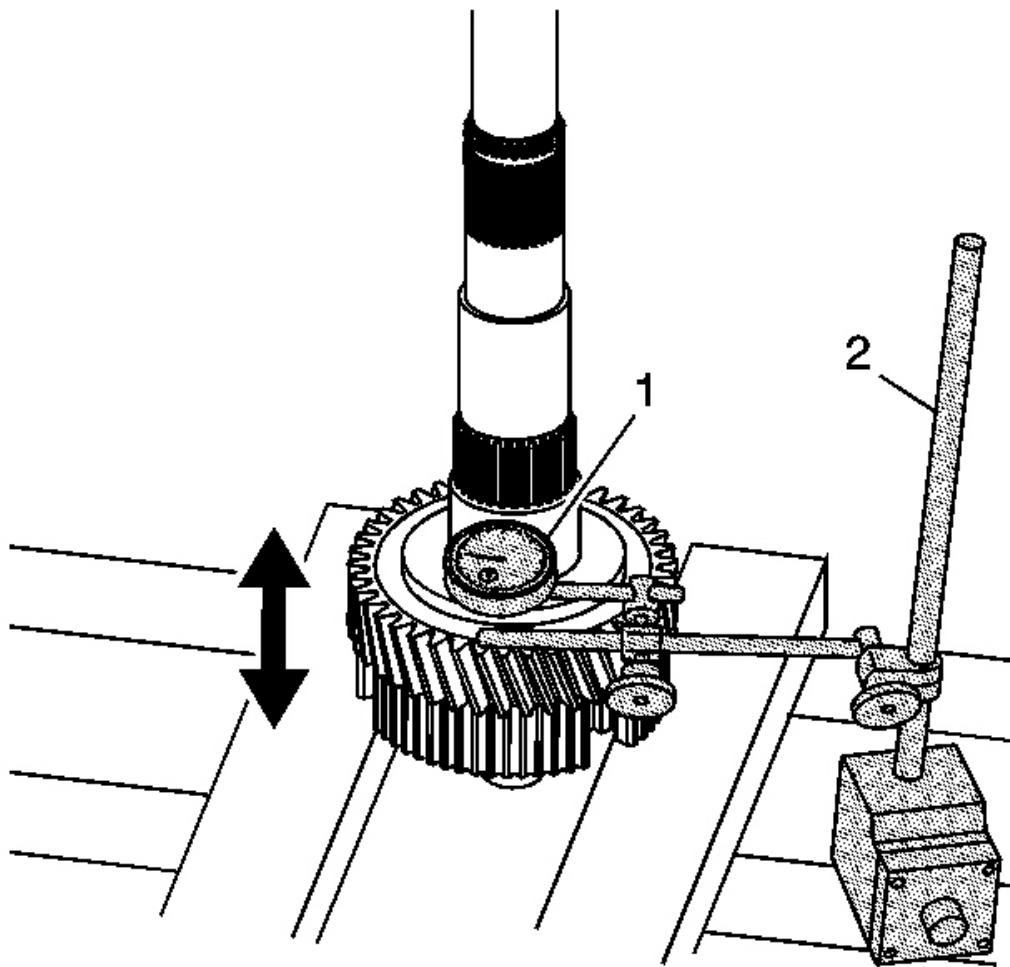

Fig. 221: Measuring 3rd Gear Axial Play
Courtesy of GENERAL MOTORS CORP.

5. Using **J 8001-3** or **J 26900-12** (1) and **J 26900-13** (2), measure the 3rd gear axial play. See **Special Tools**.

Specification:

- Standard Clearance: 0.10-0.25 mm (0.0039-0.00098 in)
 - Maximum Clearance: 0.30 mm (0.0118 in)
1. Position **J 8001-3** or **J 26900-12** (1) on the top of the gear teeth. See **Special Tools**.
 2. Zero the gage.
 3. Lift up on the gear to measure the clearance.
6. If the clearance exceeds the maximum, ensure the hub is installed completely.
 7. If the clearance exceeds the maximum, inspect the 3rd gear, the output shaft or the 3rd/4th synchronizer hub for wear.
 8. If clearance is lower than the standard clearance, inspect the 3rd gear, the output shaft or the 3rd/4th synchronizer hub for burrs.
 9. Repair or replace the damaged or worn component.

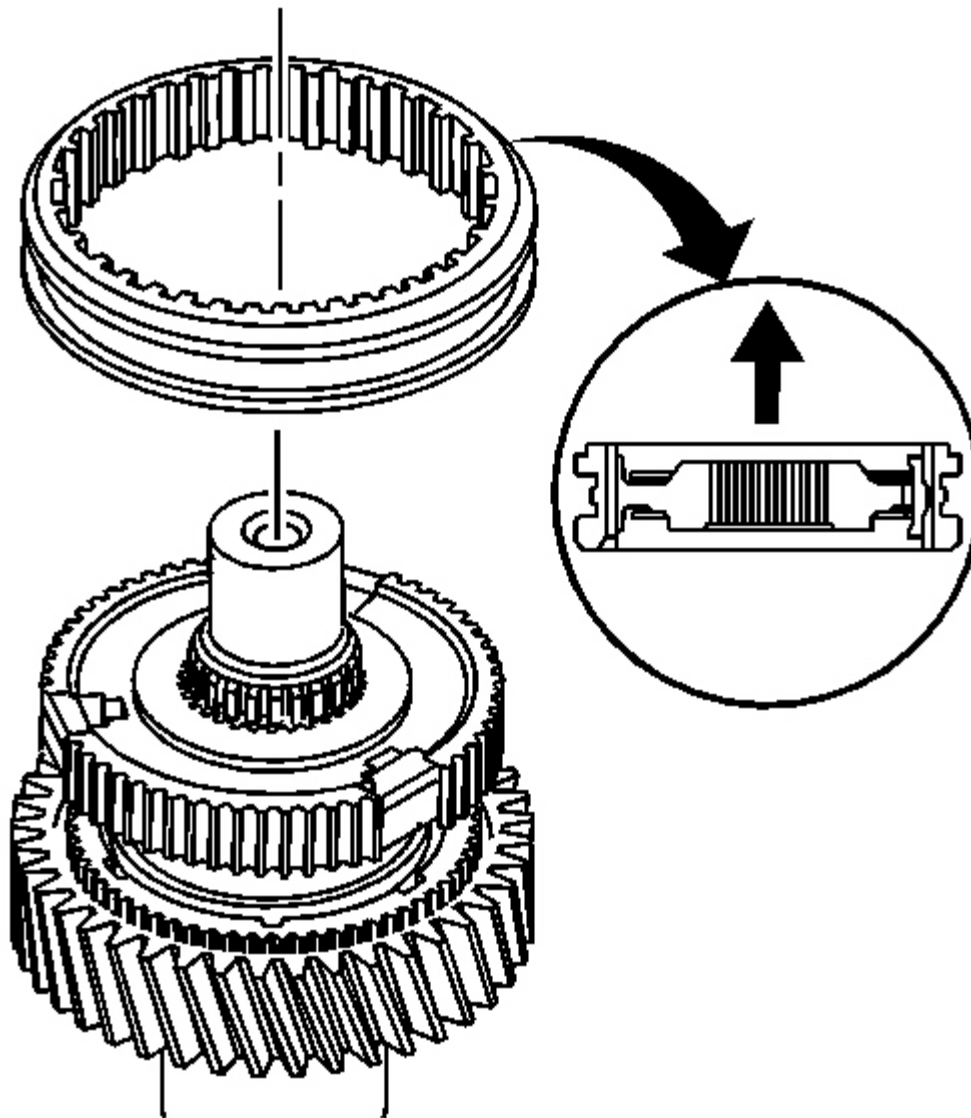

Fig. 222: Identifying 3rd/4th Synchronizer Sleeve
Courtesy of GENERAL MOTORS CORP.

10. Install the 3rd/4th synchronizer sleeve on the hub while pushing in on the inserts. The step shoulder side of the sleeve goes forward to 4th gear.

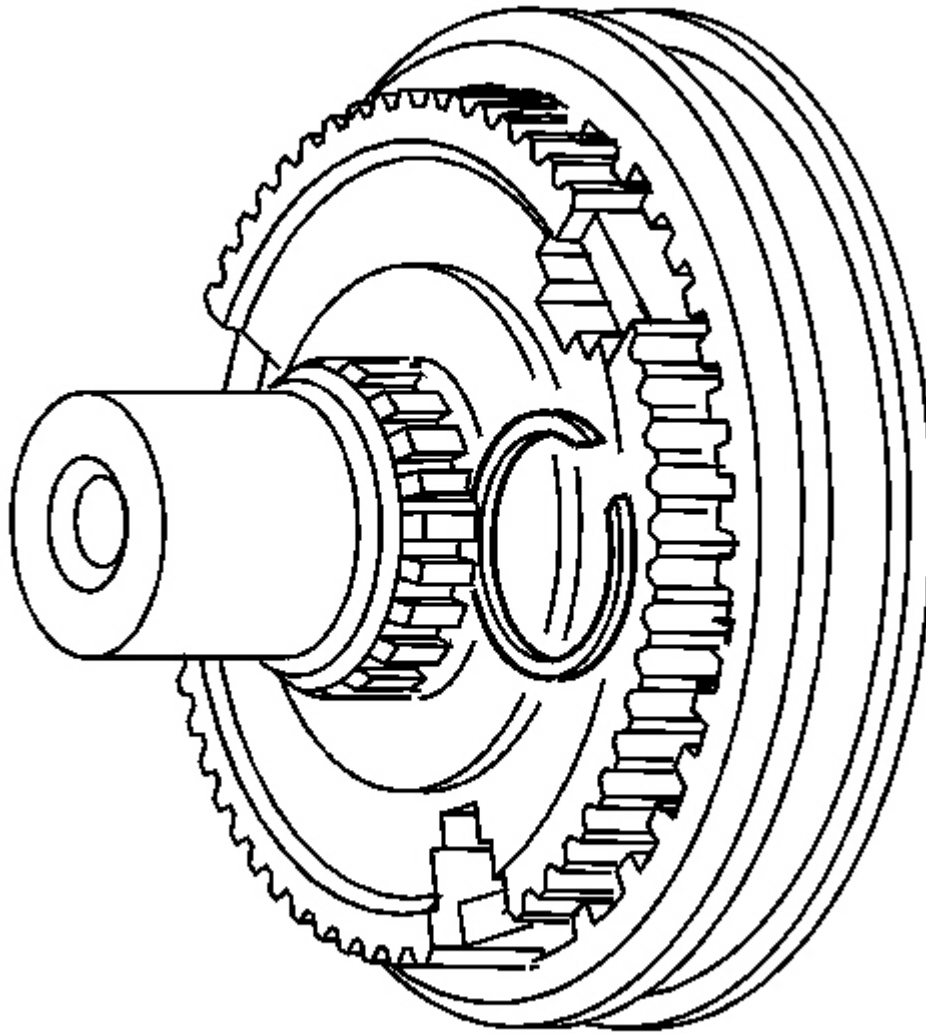

Fig. 223: Locating 3rd/4th Synchronizer Hub Retaining Ring
Courtesy of GENERAL MOTORS CORP.

IMPORTANT: The retaining ring is a select fit. Always install a new retaining ring.

11. Select the maximum thickness retaining ring for the 3rd/4th synchronizer hub, that will fit in the groove. Refer to **3rd and 4th Gear Synchronizer Retaining Ring Specifications**.

12. Install the 3rd/4th synchronizer hub retaining ring.

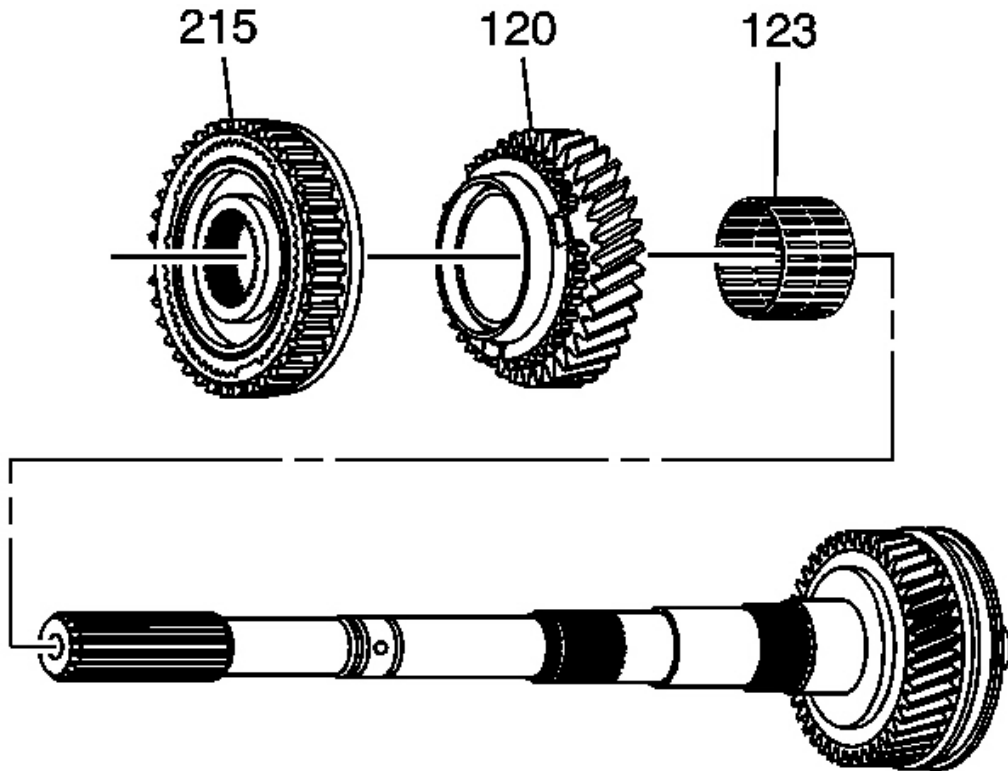

Fig. 224: View Of 1st/2nd Synchronizer Hub Assembly, 2nd Gear & Bearing
Courtesy of GENERAL MOTORS CORP.

13. Install the 2nd gear bearing (123) and the 2nd gear (120) on the rear of the output shaft.
14. Remove the 1st gear blocking rings from the 1st/2nd synchronizer assembly. The rings will be installed after pressing on the hub.
15. Install the 1st/2nd synchronizer hub assembly (215) on the output shaft, with the shift fork side of the reverse gear toward 2nd gear.

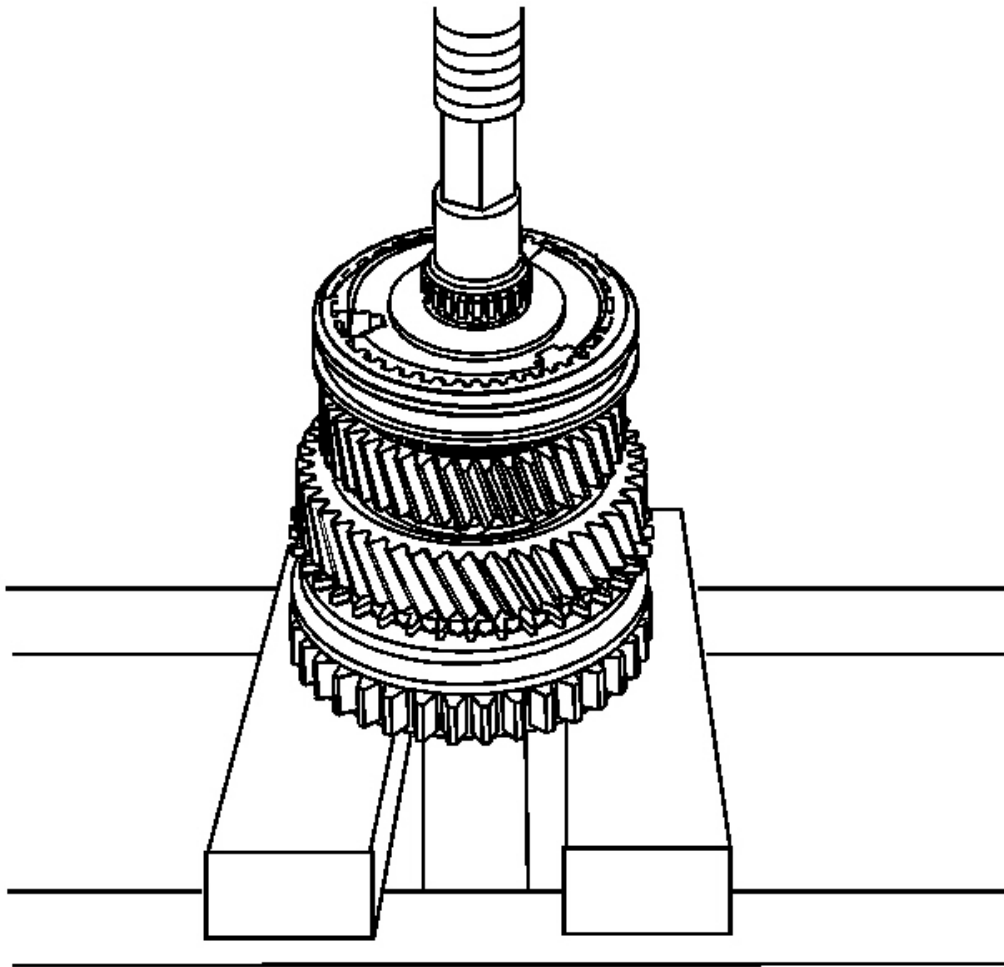

Fig. 225: Locating 1st/2nd Synchronizer Assembly
Courtesy of GENERAL MOTORS CORP.

16. Using a hydraulic press, press the 1st/2nd synchronizer assembly onto the output shaft.
 - Support the synchronizer hub on the center flange.
 - Align the tabs of the blocking rings to the notches in the synchronizer hub and the 2nd speed gear.

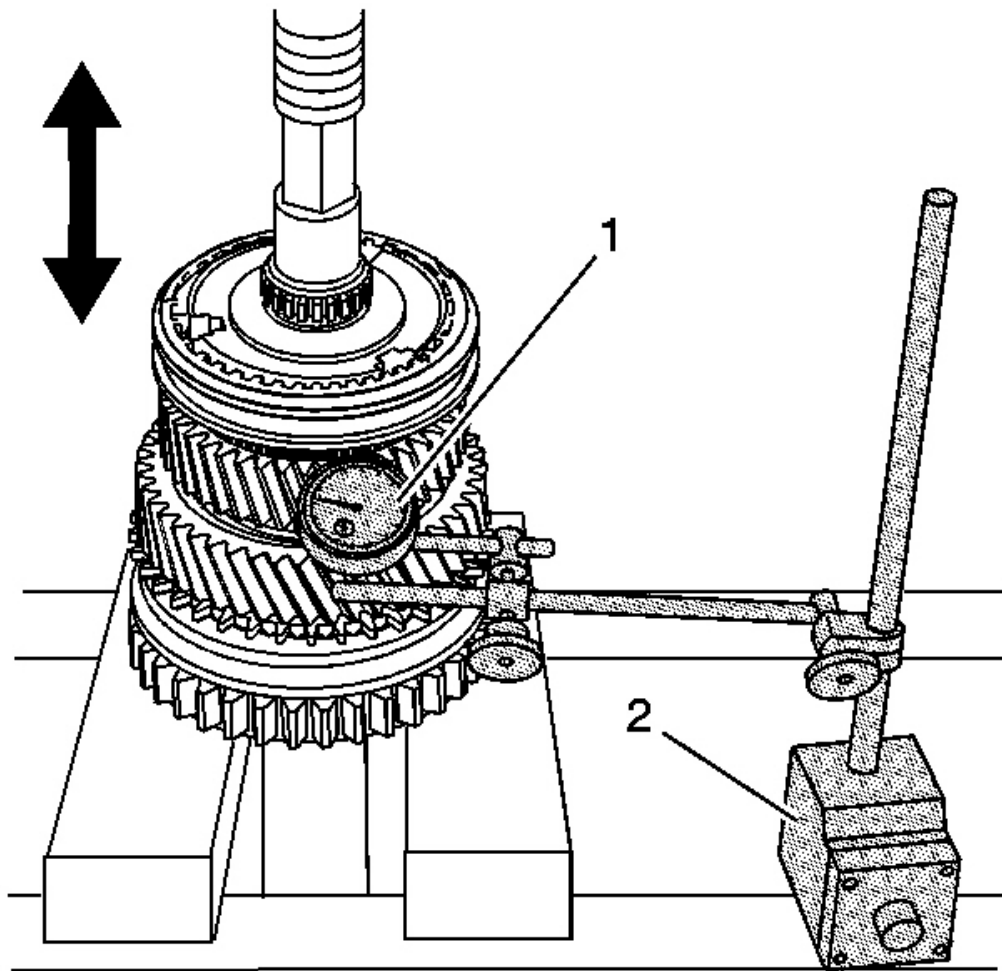

Fig. 226: Checking 2nd Gear Axial Play
Courtesy of GENERAL MOTORS CORP.

17. Using **J 8001-3** or **J 26900-12** (1) and **J 26900-13** (2), measure the 2nd gear axial play. See **Special Tools**.

Specification:

- Standard Clearance: 0.10-0.25 mm (0.0039-0.00098 in)
- Maximum Clearance: 0.30 mm (0.0118 in)

1. Position **J 8001-3** or **J 26900-12** (1) on the top of the gear teeth. See **Special Tools**.

2. Zero the gage.
3. Lift up on the gear to measure the clearance.
18. If the clearance exceeds the maximum, ensure the hub is installed completely.
19. If the clearance exceeds the maximum, inspect the 2nd gear, the output shaft or the 1st/2nd synchronizer hub for wear.
20. If clearance is lower than the standard clearance, inspect the 2nd gear, the output shaft or the 2nd/3rd synchronizer hub for burrs.
21. Repair or replace the damaged or worn component.

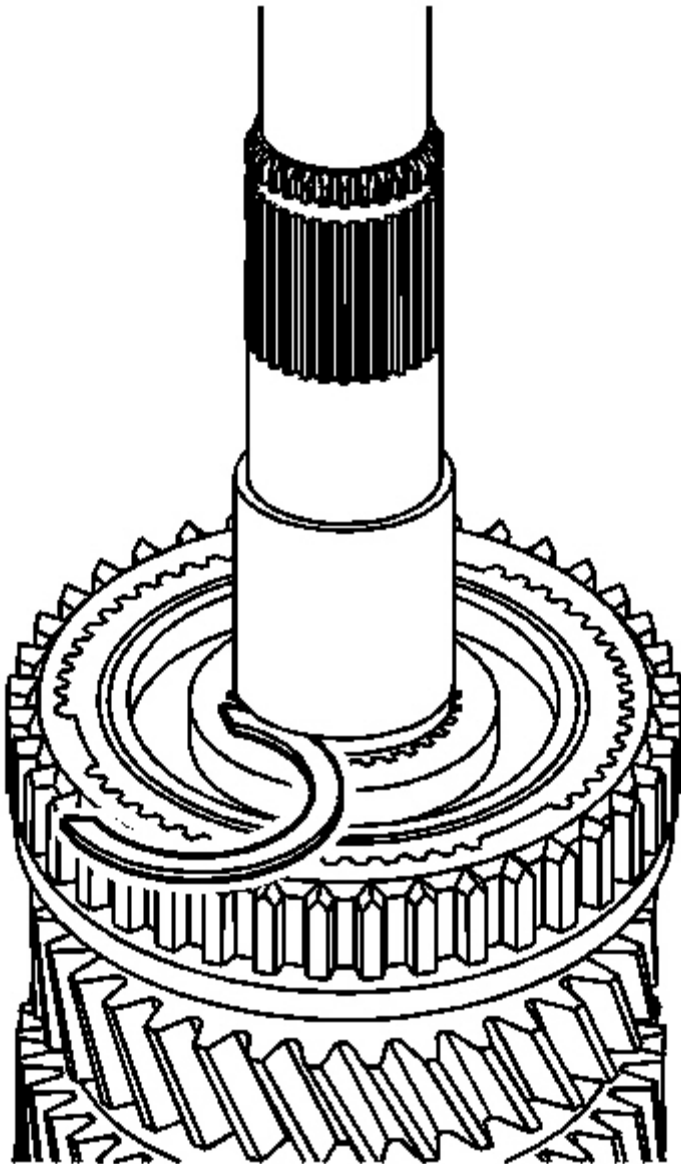

Fig. 227: View Of 1st/2nd Synchronizer Hub Retaining Ring
Courtesy of GENERAL MOTORS CORP.

IMPORTANT: The retaining ring is a select fit. Always install a new retaining ring.

22. Select the maximum thickness retaining ring for the 1st/2nd synchronizer hub, that will fit in the groove. Refer to **1st and 2nd Gear Synchronizer Retaining Ring Specifications**.
23. Install the 1st/2nd synchronizer hub retaining ring.

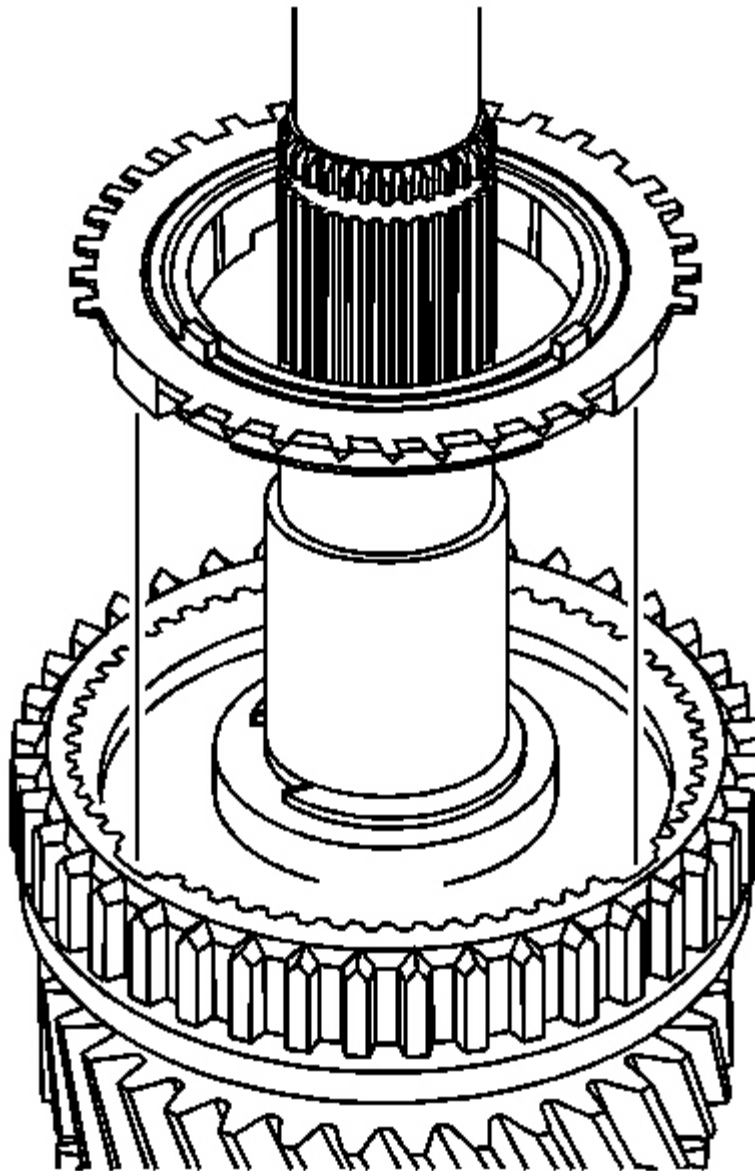

Fig. 228: Locating 1st Gear Synchronizer Rings

Courtesy of GENERAL MOTORS CORP.

24. Install the 1st gear synchronizer rings. Align the blocking ring tabs to the notches in the hub.

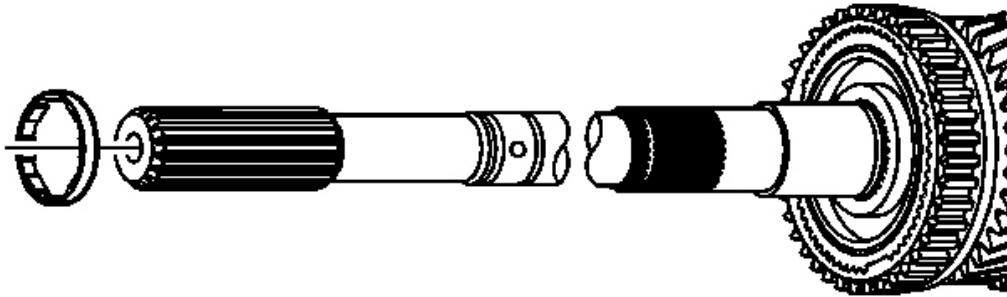

Fig. 229: View Of 1st Gear Spacer
Courtesy of GENERAL MOTORS CORP.

25. Install the 1st gear spacer.

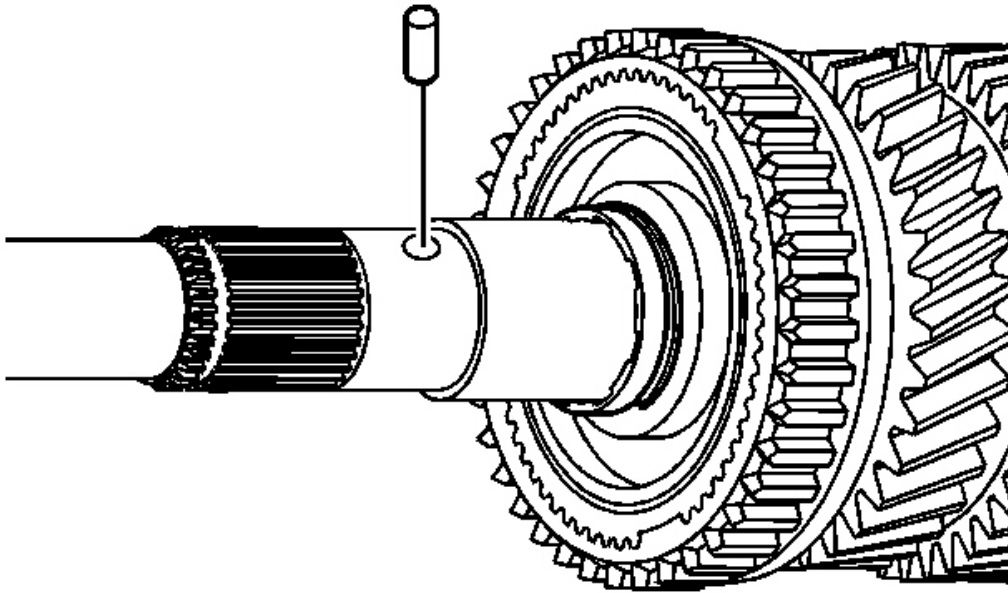

Fig. 230: Identifying 1st Gear Thrust Washer Lock Pin
Courtesy of GENERAL MOTORS CORP.

26. Install the 1st gear thrust washer lock pin.

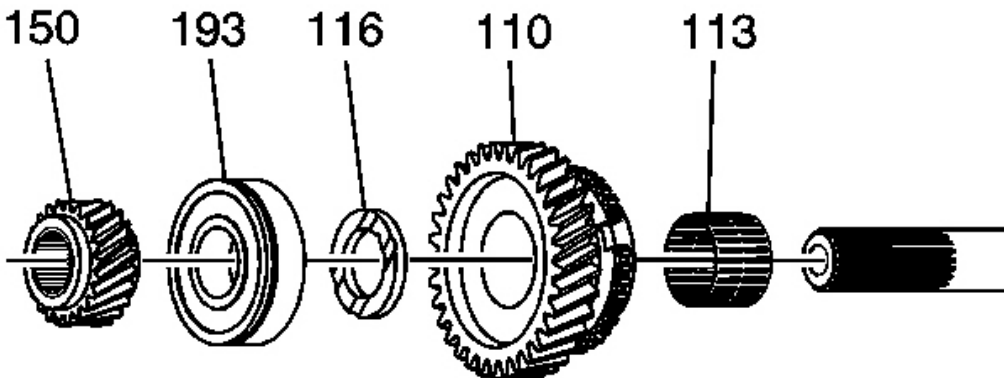

Fig. 231: Locating Output Shaft Components
Courtesy of GENERAL MOTORS CORP.

27. Install the following components to the rear of the output shaft:
- The 1st gear bearing (113)
 - The 1st gear (110)
 - The 1st gear thrust washer (116)
 - The output shaft rear bearing (193)
 - The 5th gear (150)

The shorter shoulder goes toward the bearing.

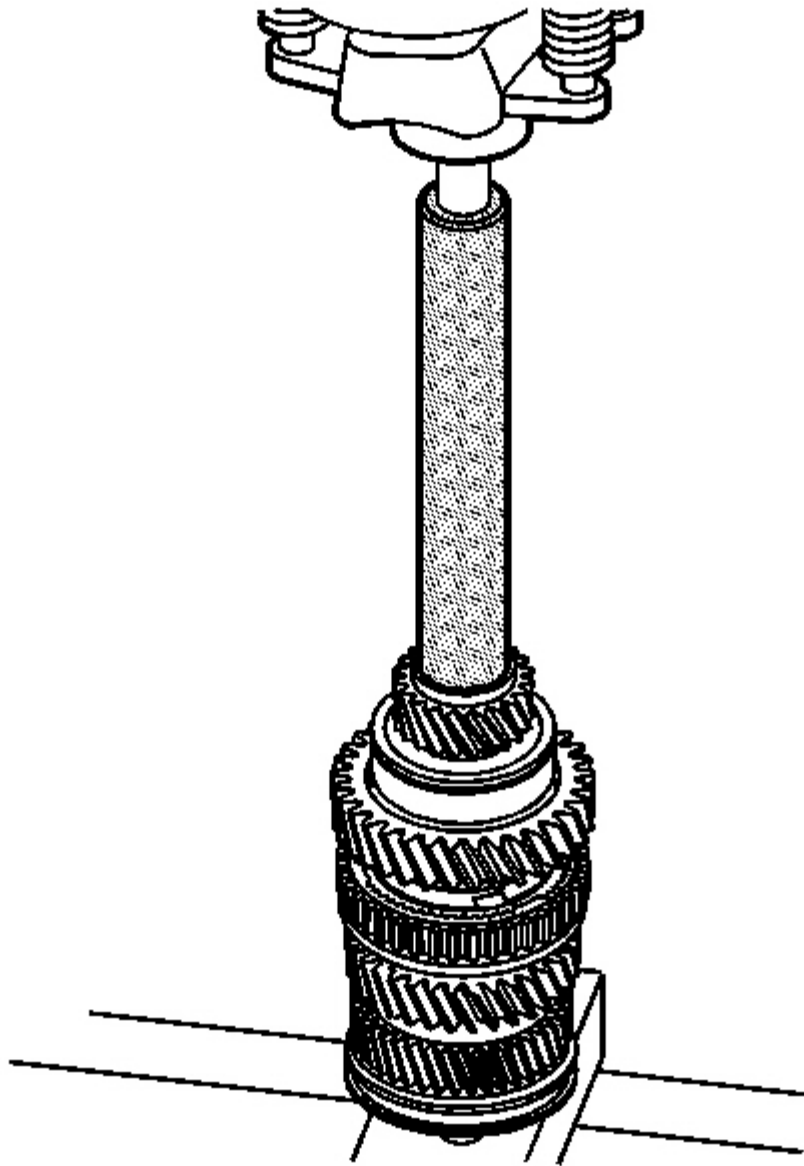

Fig. 232: Pressing Output Rear Bearing & 5th Gear Onto Output Shafting
Courtesy of GENERAL MOTORS CORP.

28. Using a hydraulic press and **J 6133-A** for 4WD or **J 44340** for RWD, press the output rear bearing and the 5th gear onto the output shaft. See **Special Tools**.

- Ensure the tabs of the blocking rings align to the notches in the synchronizer hub.
- The retaining ring groove side of the bearing faces 5th gear.

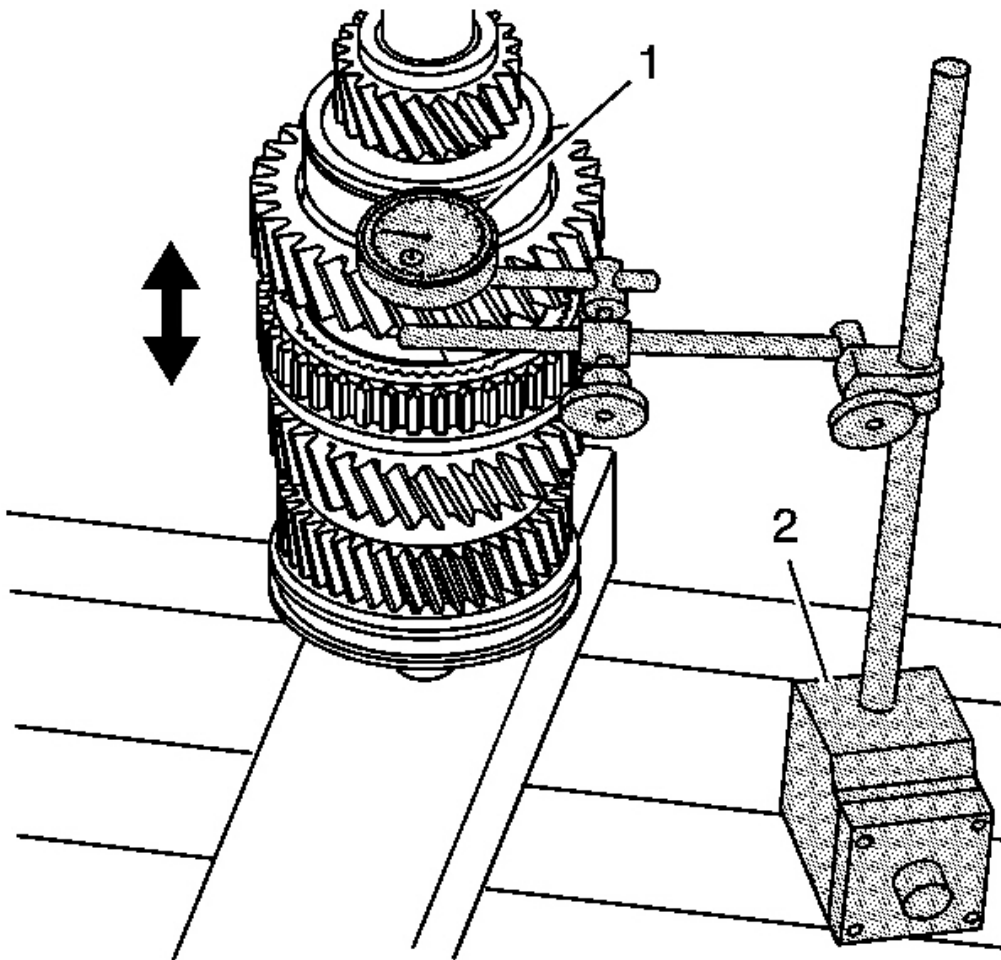

Fig. 233: Measuring 1st Gear Axial Play
Courtesy of GENERAL MOTORS CORP.

29. Using J 8001-3 or J 26900-12 (1) and J 26900-13 (2), measure the 1st gear axial play. See **Special Tools**.

Specification:

- Standard Clearance: 0.20-0.45 mm (0.0079-0.0177 in)

- Maximum Clearance: 0.50 mm (0.0197 in)
 1. Position **J 8001-3** or **J 26900-12** (1) on the top of the gear teeth. See **Special Tools**.
 2. Zero the gage.
 3. Lift up on the gear to measure the clearance.
- 30. If the clearance exceeds the maximum, ensure the rear output shaft bearing is installed completely.
- 31. If the clearance exceeds the maximum, inspect the 1st gear, the output shaft or the thrust washer for wear.
- 32. If clearance is lower than the standard clearance, inspect the 1st gear, the output shaft or the thrust washer for burrs.
- 33. Repair or replace the damaged or worn component.

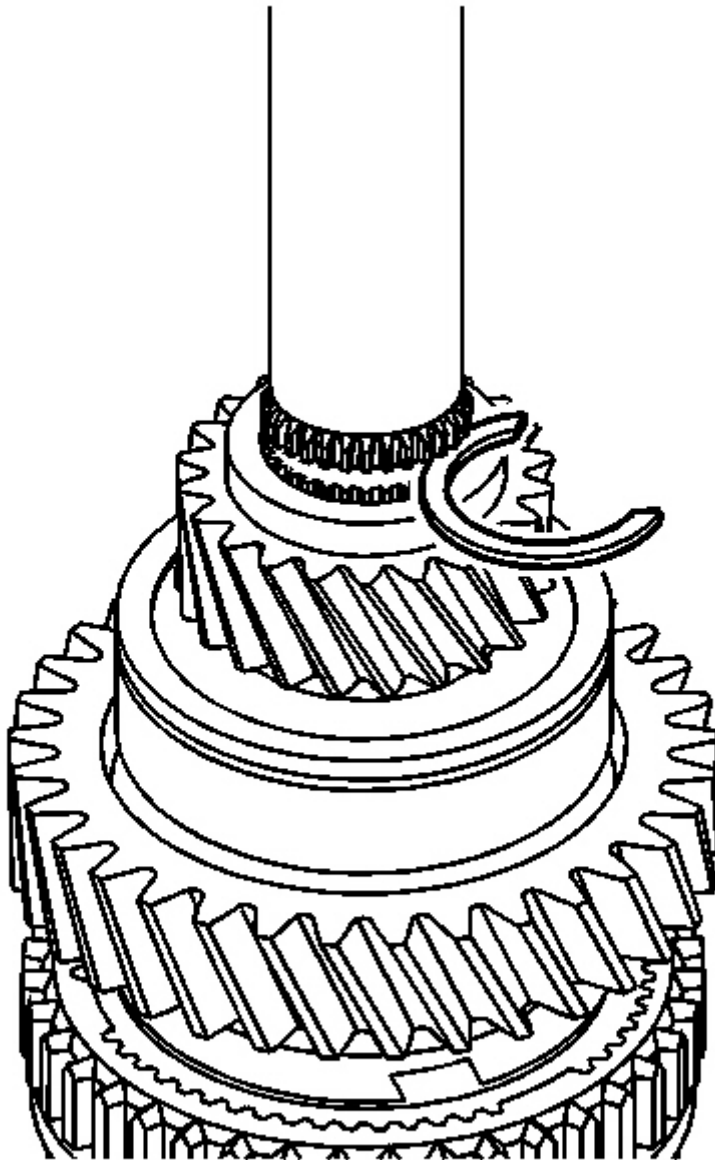

Fig. 234: Identifying 5th Gear Retaining Ring
Courtesy of GENERAL MOTORS CORP.

IMPORTANT: The retaining ring is a select fit. Always install a new retaining ring.

34. Select the maximum thickness retaining ring for the 5th gear, that will fit in the groove. Refer to **Fifth Gear Retaining Ring Specifications**.
35. Install the 5th gear retaining ring.

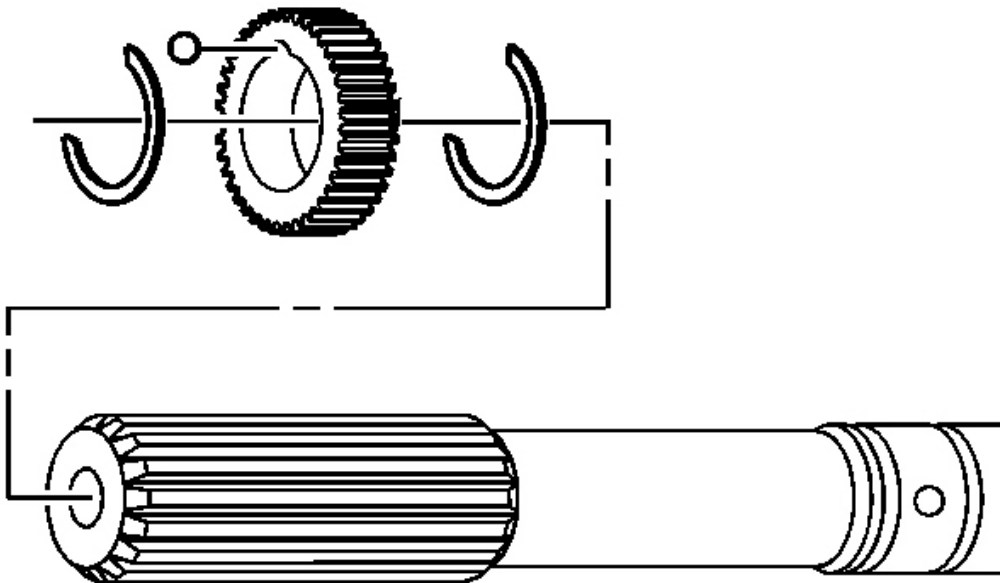

Fig. 235: View Of Speed Sensor Reluctor Wheel Front Retaining Ring, Wheel & Ball
Courtesy of GENERAL MOTORS CORP.

36. If RWD, install the speed sensor reluctor wheel front retaining ring.
37. Install the speed sensor reluctor wheel locating ball.
38. Install the speed sensor reluctor wheel.
39. Install the speed sensor reluctor wheel rear retaining ring.

TRANSMISSION ASSEMBLE

Tools Required

- **J 39924-2** 5th Gear Drag Seal Installer. See **Special Tools**.
- **J 45866** Input Shaft Seal Installer. See **Special Tools**.
- **J 45867** 4WD Output Shaft Seal Installer. See **Special Tools**.

- **J 45868** RWD Output Shaft Seal Installer. See **Special Tools**.

Assembly Procedure

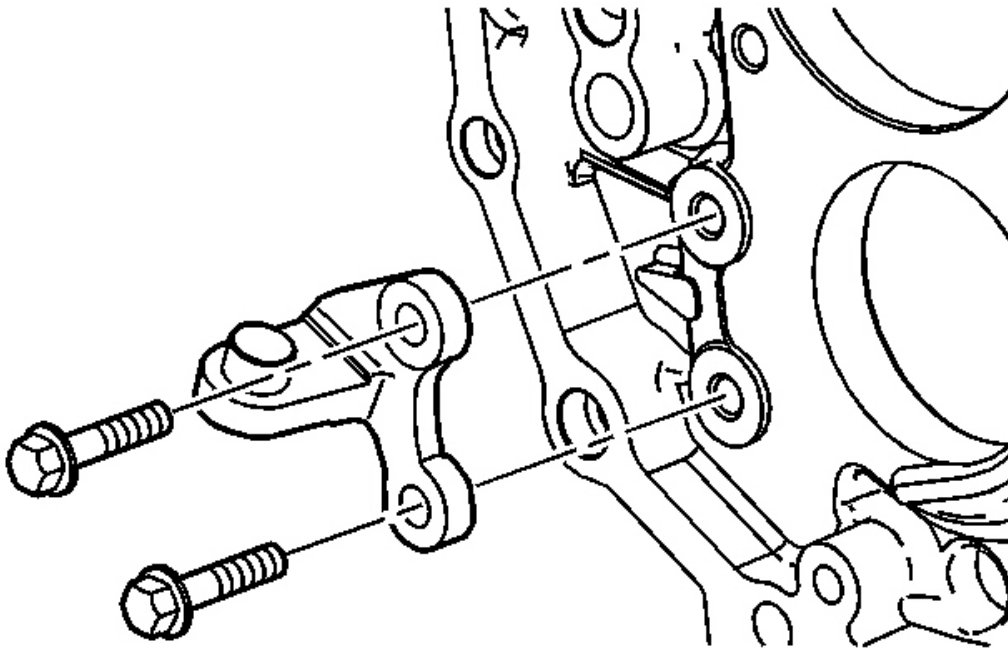

Fig. 236: View Of Reverse Shift Fork Bracket & Bolts
Courtesy of GENERAL MOTORS CORP.

IMPORTANT:

- Lubricate all bearings with transmission fluid during assembly.
- The following steps apply to both the 4WD and the RWD transmission, except where noted.

1. Install 2 bolts, with nuts, in the lower holes of the intermediate case. The bolts will be used to hold the intermediate case in a vise during assembly.

NOTE: Refer to **Machined Surface Damage Notice** .

2. Mount the intermediate case in a vise on the previously installed bolts.

NOTE: Refer to Fastener Notice .

3. Install the reverse shift fork bracket with bolts.

Tighten: Tighten the bracket bolts to 18 N.m (13 lb ft).

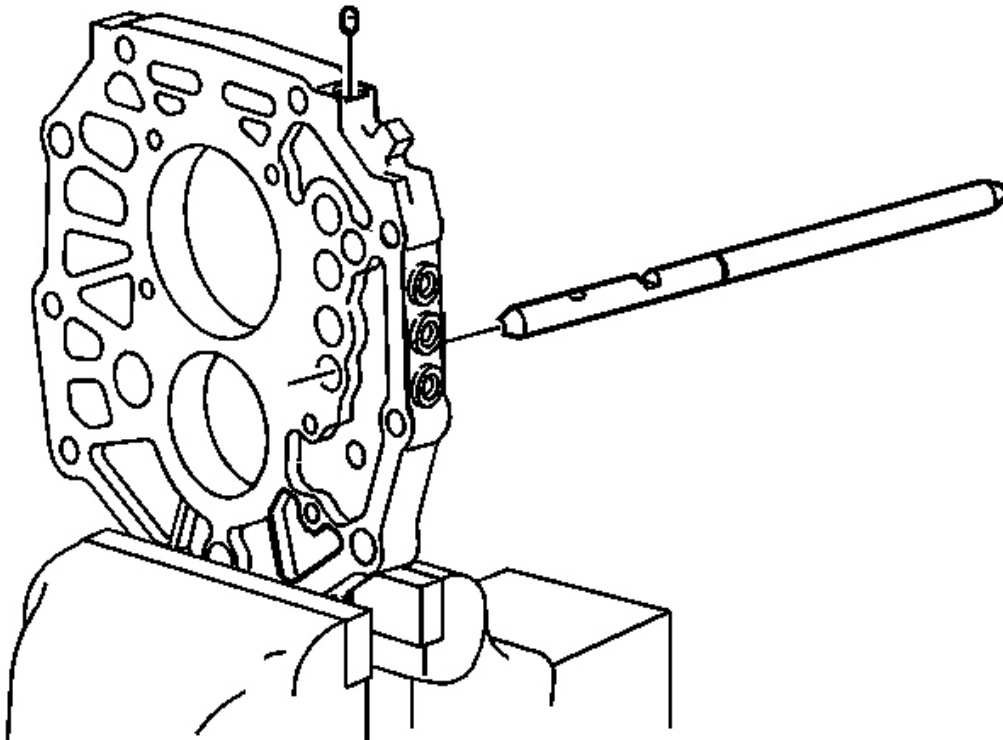

Fig. 237: Locating Reverse Gear Shift Shaft
Courtesy of GENERAL MOTORS CORP.

4. Install the reverse gear shift shaft.
5. Turn the shift shaft to align the interlock hole facing up.
6. Using a magnet, install the reverse shift shaft interlock.

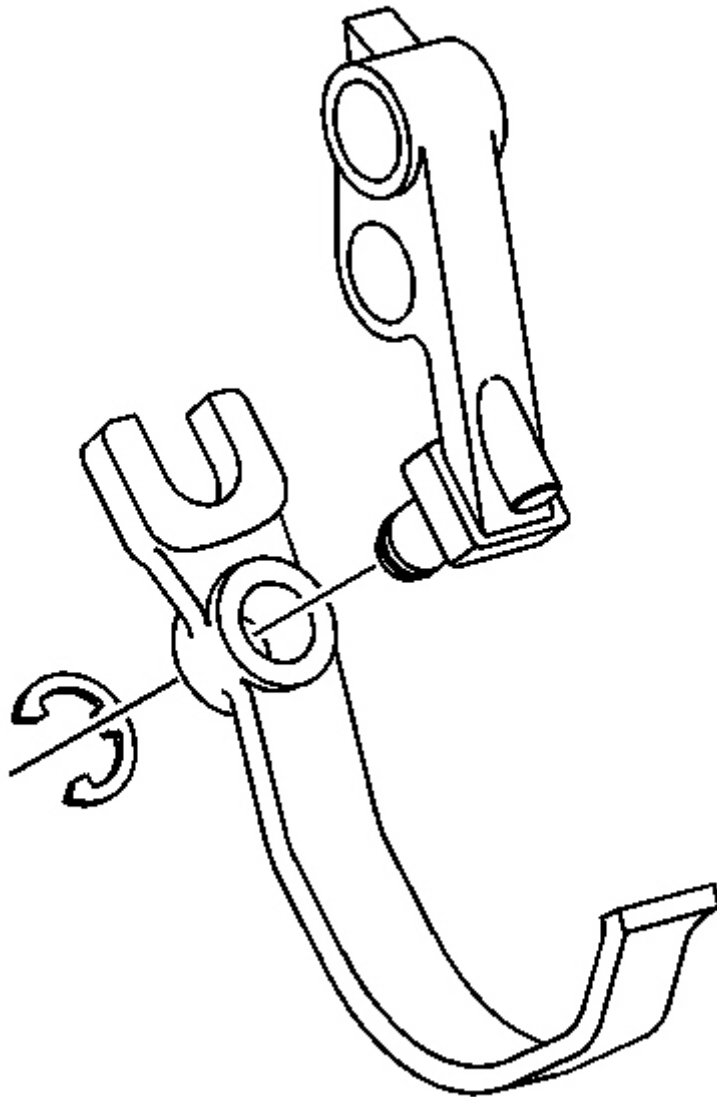

Fig. 238: View Of Reverse Shift Fork Retaining Ring & Lever
Courtesy of GENERAL MOTORS CORP.

7. Install the reverse shift fork on the reverse shift lever.
8. Install the reverse shift fork retaining ring.

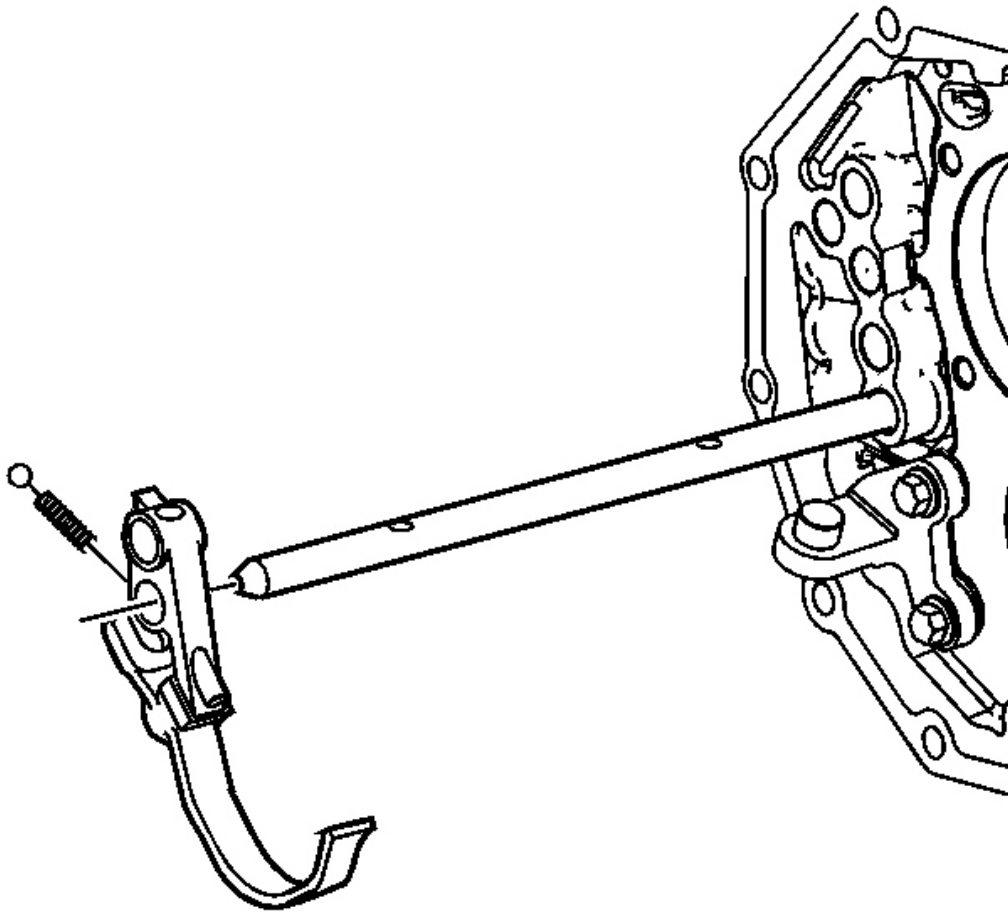

Fig. 239: Locating Detent Spring & Ball
Courtesy of GENERAL MOTORS CORP.

9. Install the reverse shift lever on the reverse shift shaft.
 1. Install the detent spring in the lever.
 2. Install the detent ball. Push the ball in while sliding the lever on the shaft.
 3. Slide the lever on the shaft until the detent ball is located in the detent on the shaft.

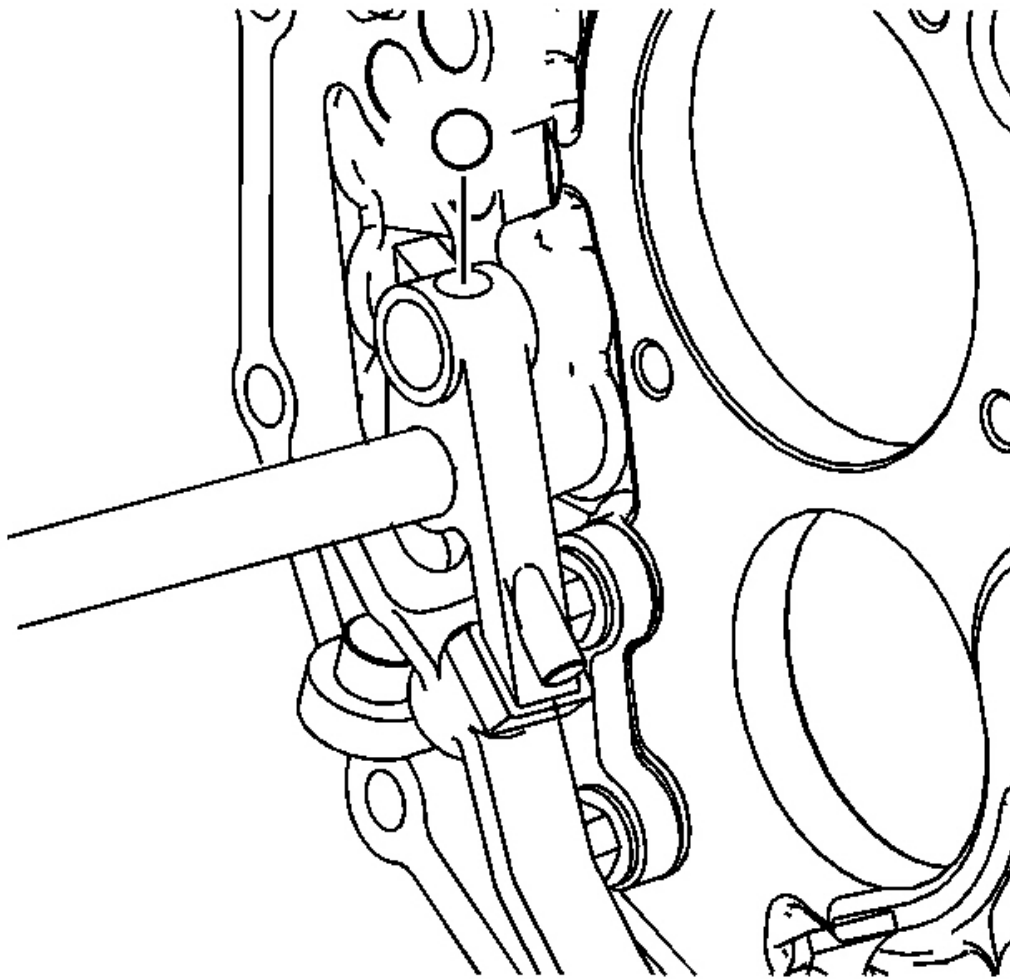

Fig. 240: Identifying Detent Ball In Reverse Shift Lever
Courtesy of GENERAL MOTORS CORP.

10. Install the detent ball in the reverse shift lever for the 5th shift shaft.

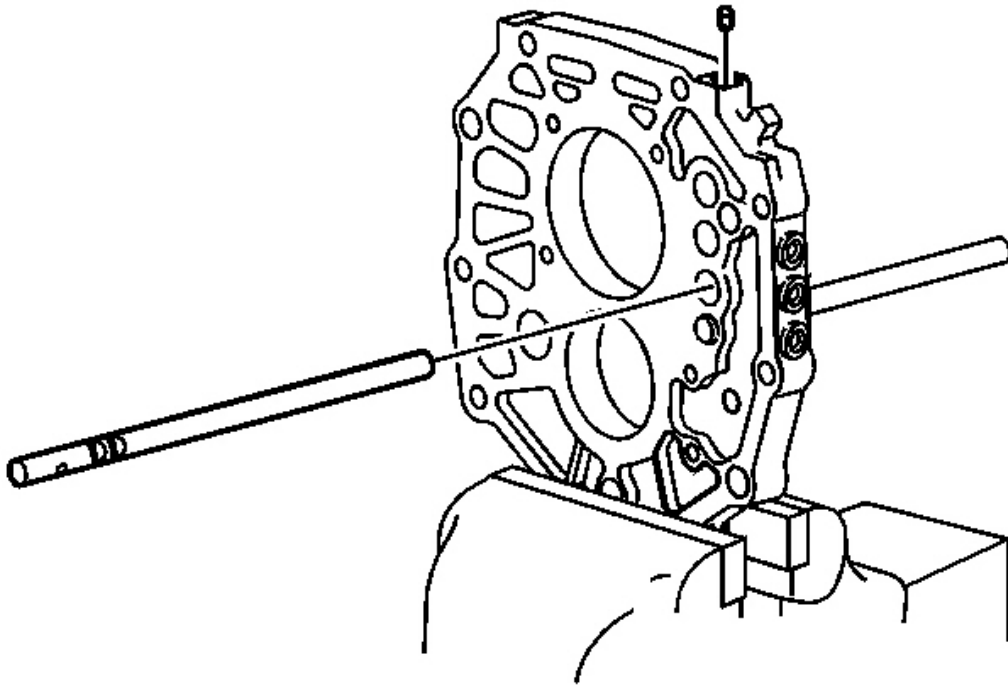

Fig. 241: View Of 5th Shift Shaft & Detent Ball
Courtesy of GENERAL MOTORS CORP.

11. Install the 5th shift shaft into the intermediate case.
12. Push down on the detent ball in the reverse shift lever and install the 5th shift shaft.
13. Align the 5th shift shaft with the detents facing toward the detent ball hole at the side of the case.
14. Using a magnet, install the 1st/2nd shift shaft and 5th shift shaft interlock pin.

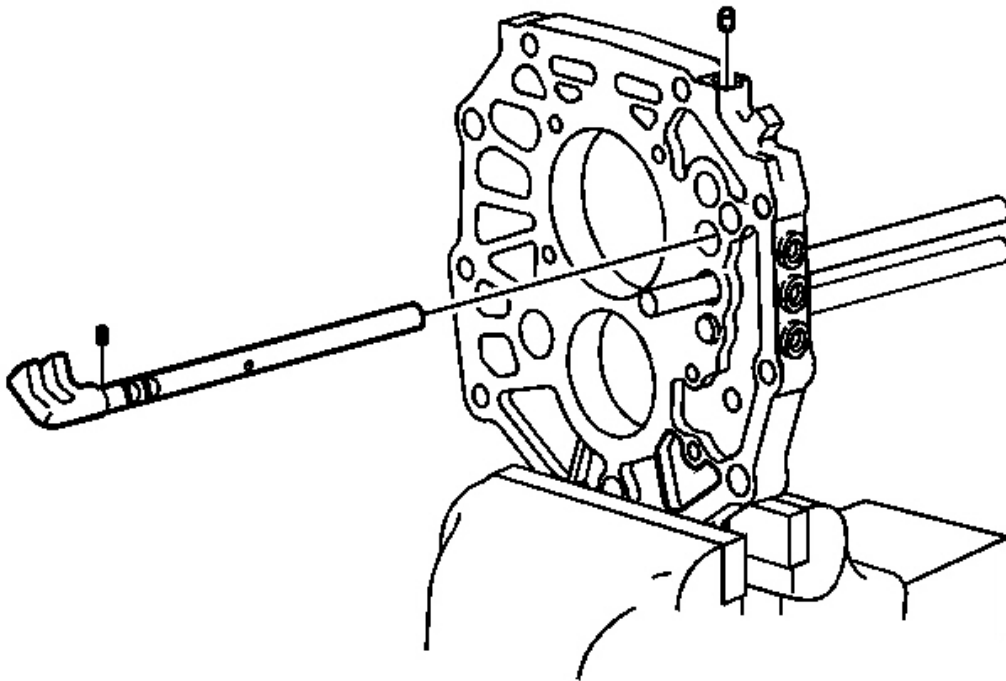

Fig. 242: Locating 1st/2nd Shift Shaft
Courtesy of GENERAL MOTORS CORP.

15. Install the small interlock pin in the 1st/2nd shift shaft.
16. Install the 1st/2nd shift shaft. Ensure to align the interlock pin with the interlock in the 5th shift shaft and the detents toward the detent ball hole in the side of the case.
17. Using a magnet, install the 1st/2nd shift shaft and 3rd/4th shift shaft interlock pin.

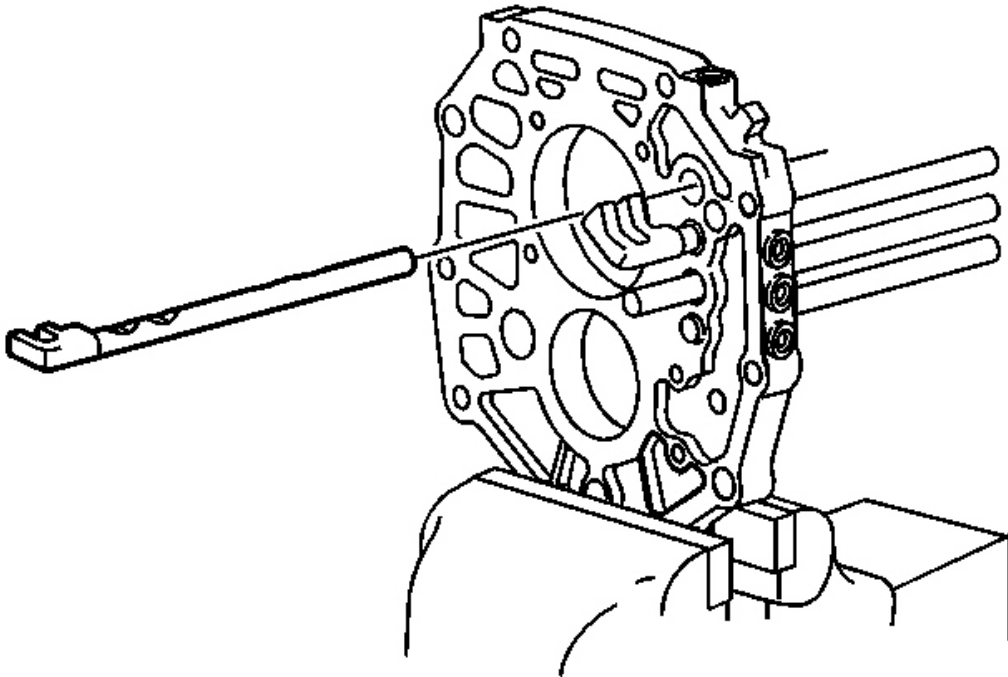

Fig. 243: Identifying 3rd/4th Shift Shaft
Courtesy of GENERAL MOTORS CORP.

18. Install the 3rd/4th shift shaft. Align the detents on the shaft toward the detent ball holes at the top of the case.

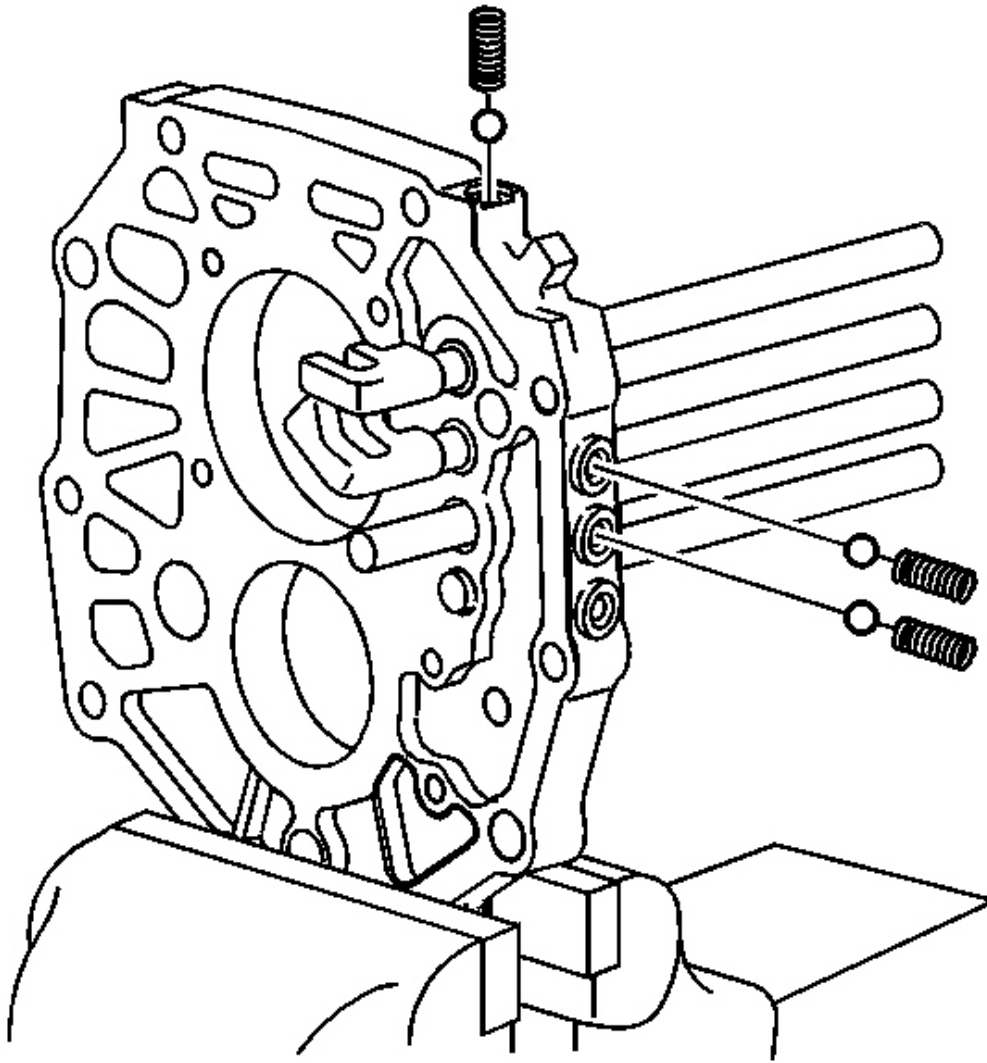

Fig. 244: View Of Shift Shaft Detent Springs & Balls
Courtesy of GENERAL MOTORS CORP.

19. Install the 5th shift shaft detent spring and ball. The reverse gear shift shaft does not have a detent spring and ball in the plug opening.
20. Install the 3rd/4th shift shaft detent spring and ball.
21. Install the 1st/2nd shift shaft detent spring and ball.

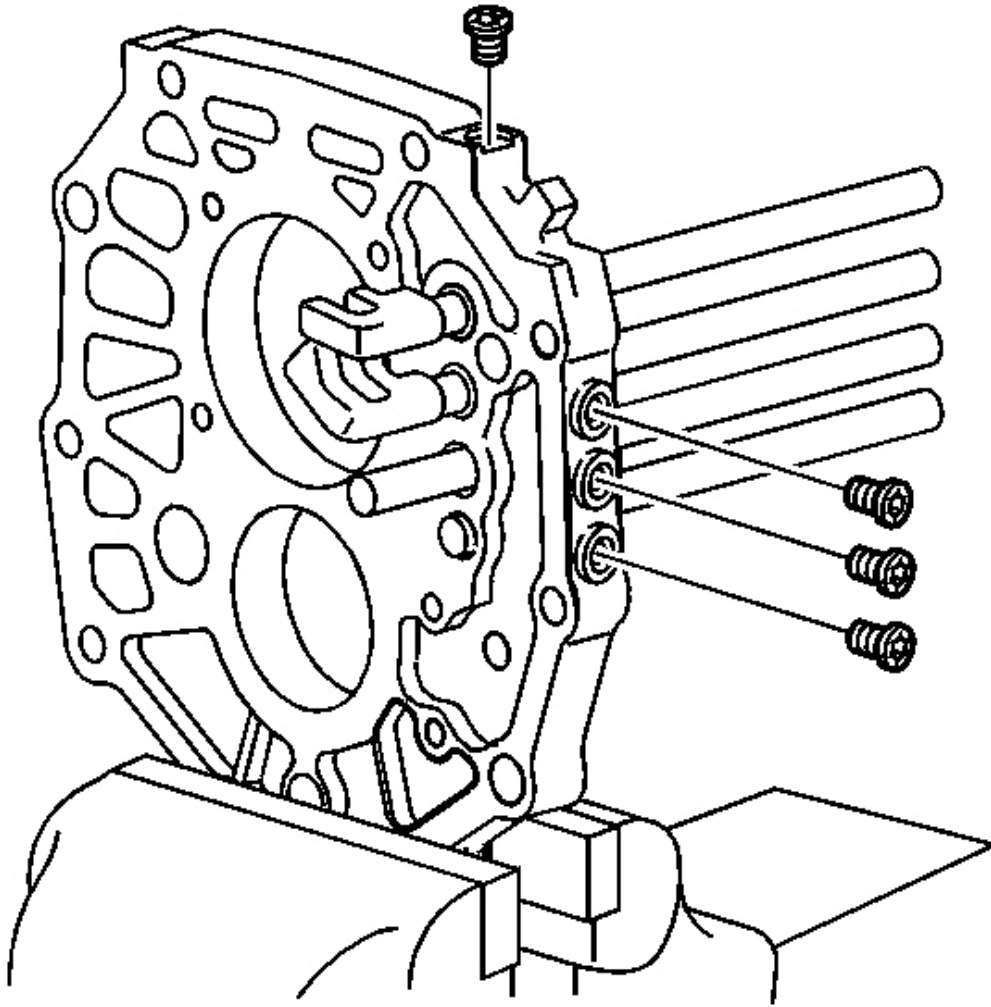

Fig. 245: Locating Shift Shaft Detent Plugs
Courtesy of GENERAL MOTORS CORP.

IMPORTANT: The shift detent plugs must not be used again. Always install new plugs.

22. Install the 4 new shift detent plugs for the balls and springs.

Tighten: Tighten the shift detent plugs to 19 N.m (14 lb ft).

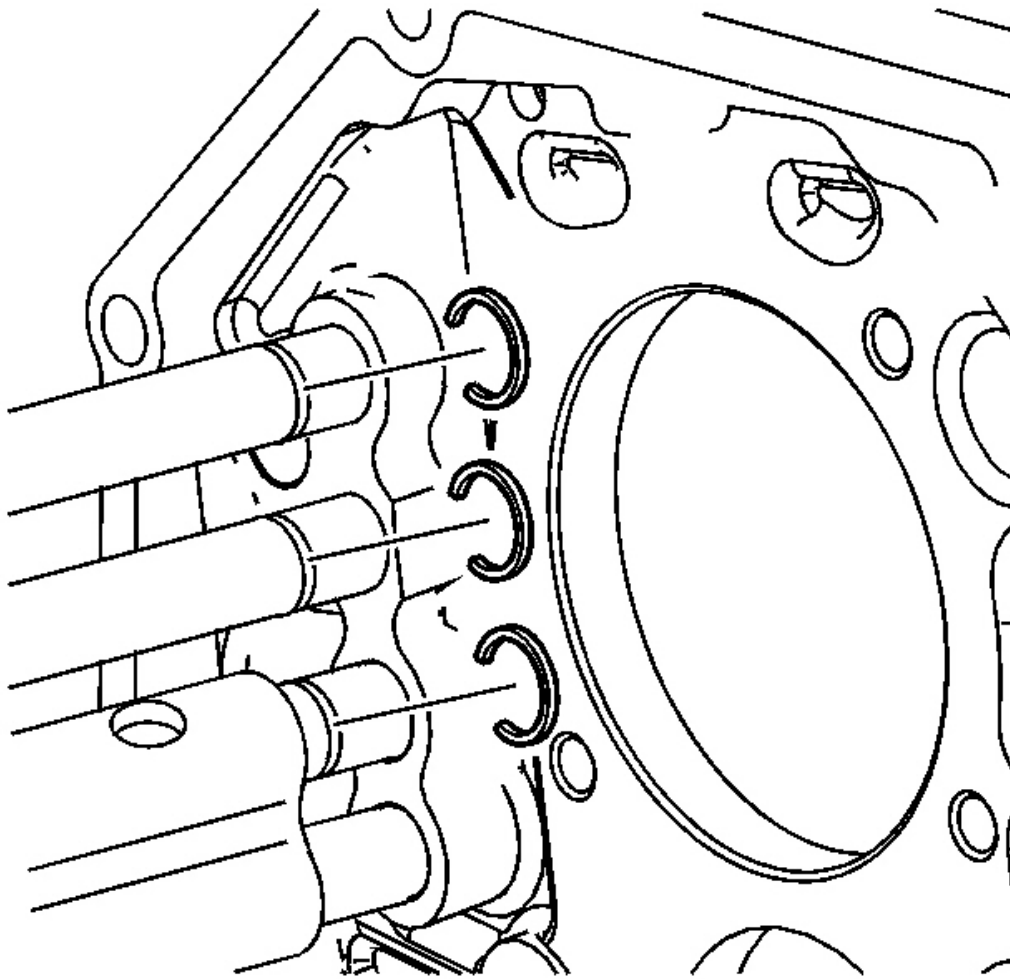

Fig. 246: Identifying Shift Shaft Retaining Rings
Courtesy of GENERAL MOTORS CORP.

IMPORTANT:

- Always use new retaining rings.
- Do not install the retaining ring for the reverse shift shaft at this time.

23. Install the 1st/2nd shift shaft retaining ring.
24. Install the 3rd/4th shift shaft retaining ring.
25. Install the 5th shift shaft retaining ring.

26. Move the shift shafts in the NEUTRAL position.

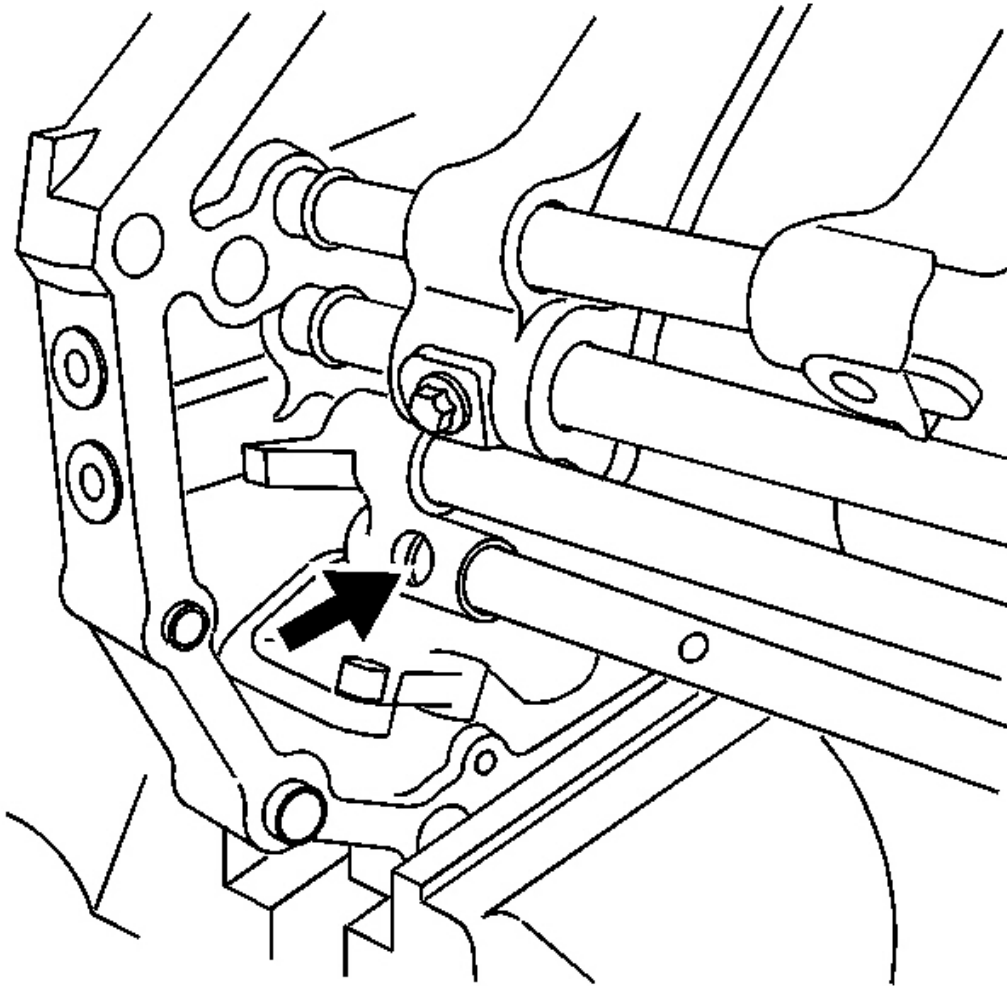

Fig. 247: View Of Retaining Ring Groove On Reverse Shift Shaft
Courtesy of GENERAL MOTORS CORP.

27. Shift the reverse shift shaft forward.
28. Move the reverse shift lever forward past the retaining ring groove on the reverse shift shaft. This allows the output shaft to clear the reverse shift fork during installation.

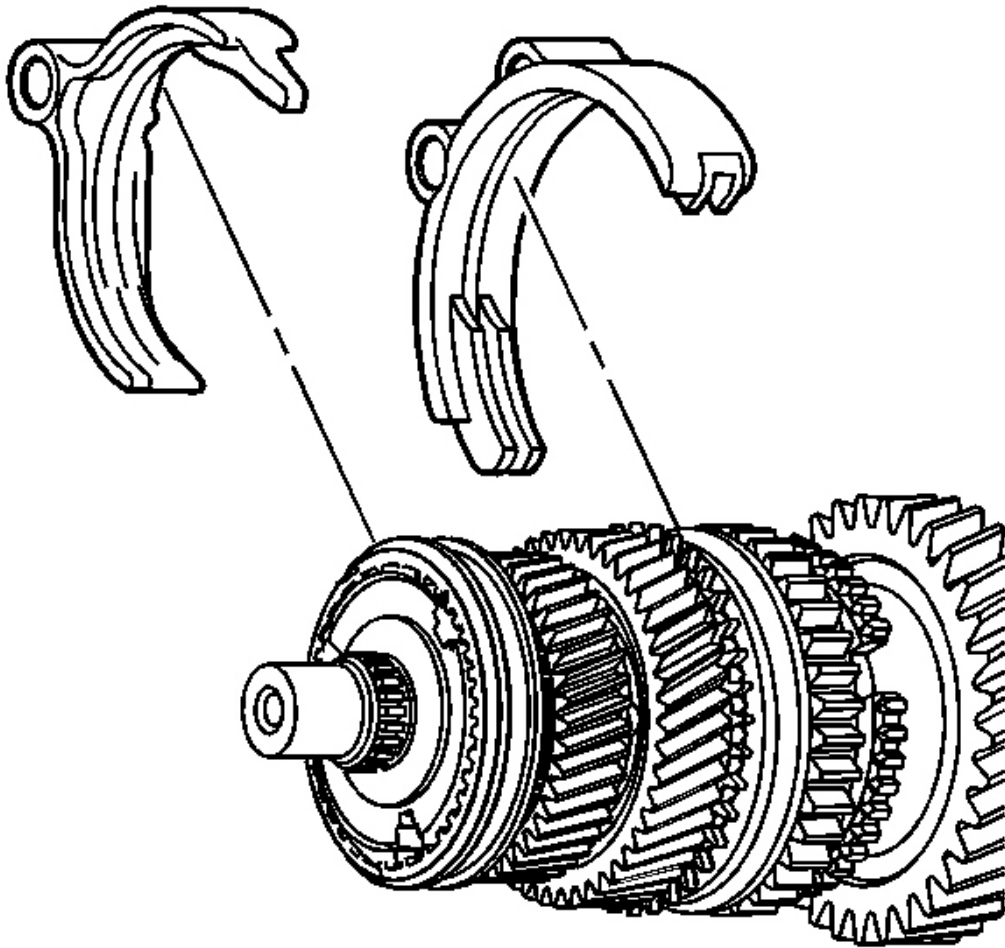

Fig. 248: Locating 3rd/4th Shift Fork And 1st/2nd Shift Fork
Courtesy of GENERAL MOTORS CORP.

29. Position the 3rd/4th shift fork and the 1st/2nd shift fork on the synchronizer sleeves. To aid during assembly, hold the shift forks in place with rubber bands.

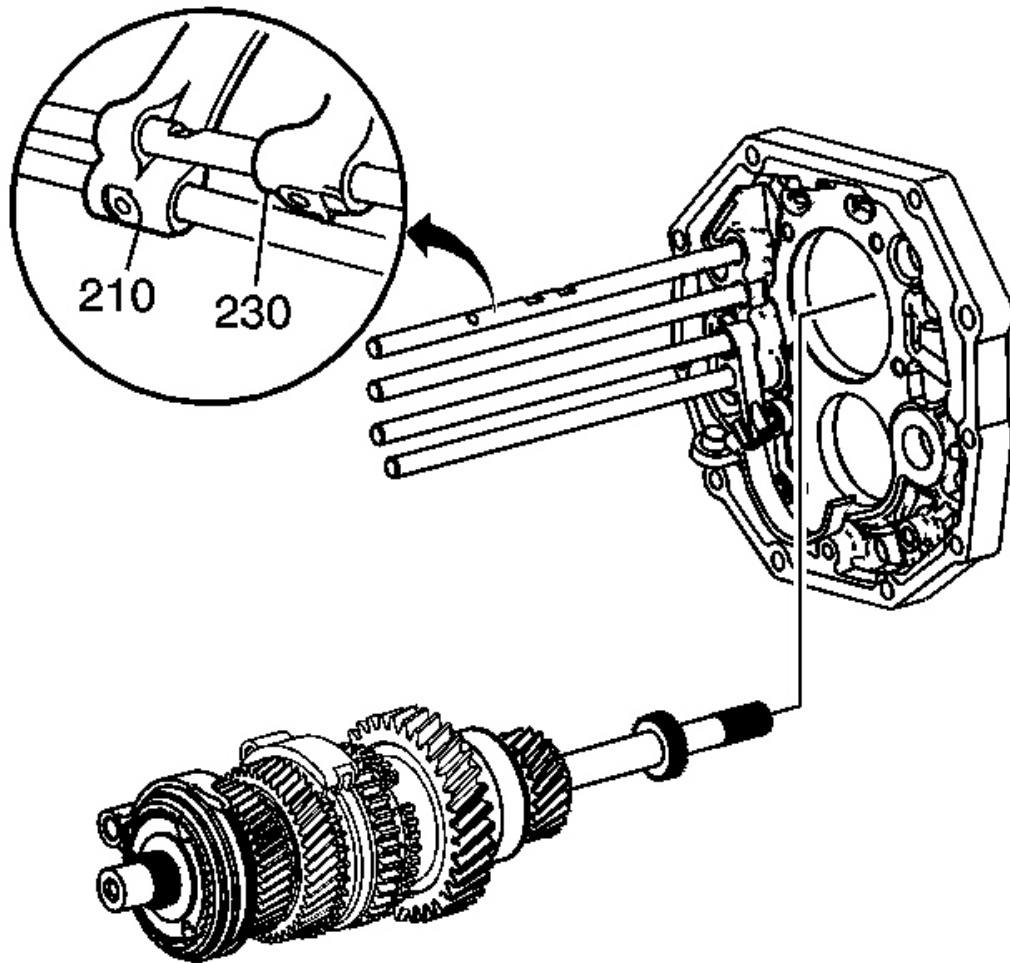

Fig. 249: Identifying 1st/2nd Shift Fork & 3rd/4th Shift Fork On Output Shaft Assembly

Courtesy of GENERAL MOTORS CORP.

30. Install the output shaft assembly.
 - Hold the 1st/2nd shift fork (210) and the 3rd/4th shift fork (230) in position to the output shaft.
 - While installing the output shaft, slide the 1st/2nd shift fork (210) and the 3rd/4th shift fork (230) on the shift shafts.
 - The 1st/2nd shift fork (210) goes on the top 2 shift shafts.

- The 3rd/4th shift fork (230) goes on the top shaft.
- Wiggle the output shaft assembly to install the output shaft rear bearing in the intermediate case.

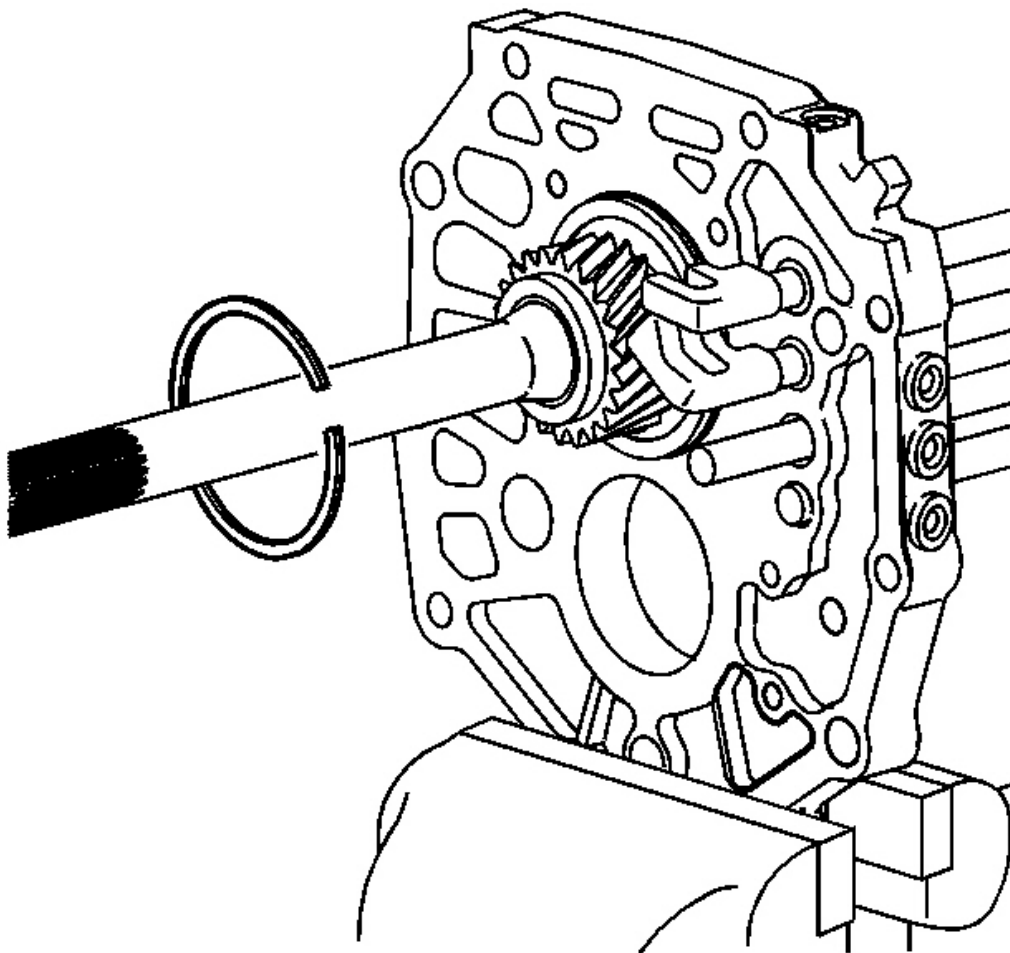

Fig. 250: View Of Output Shaft Rear Bearing Outer Retaining Ring
Courtesy of GENERAL MOTORS CORP.

31. Install the output shaft rear bearing outer retaining ring.

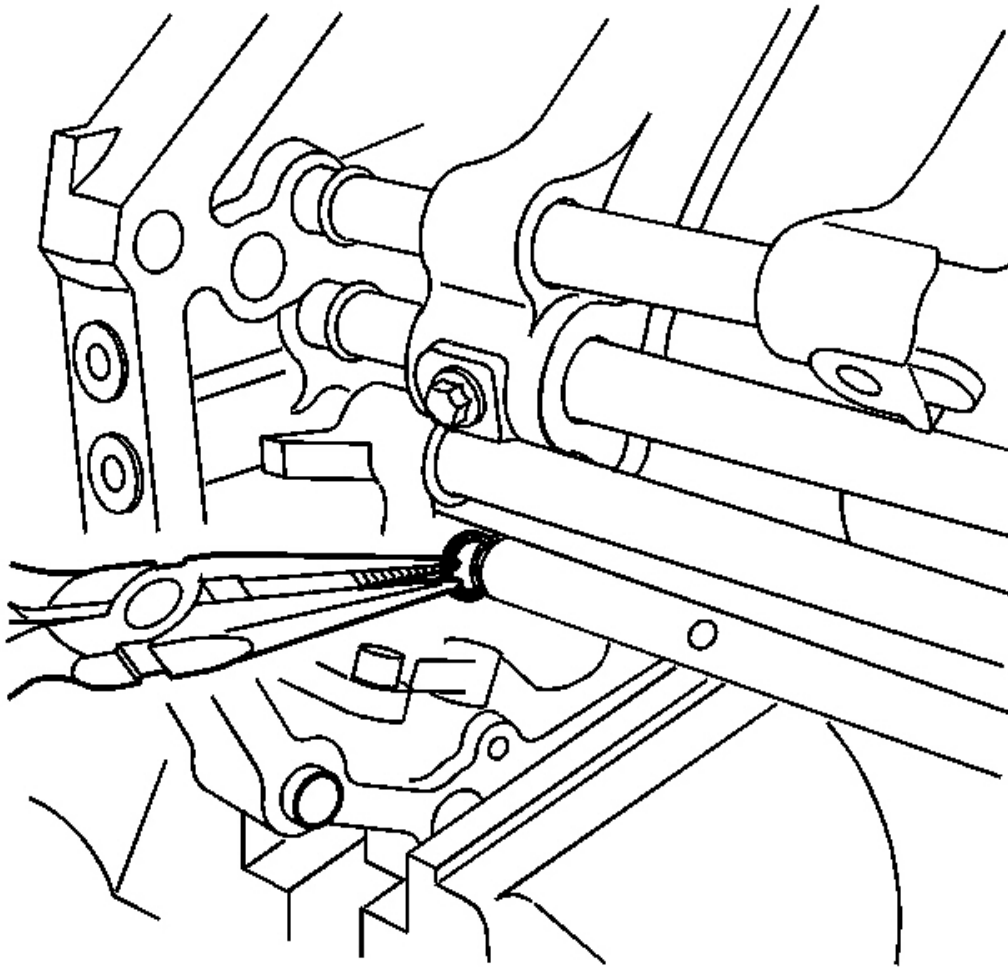

Fig. 251: Locating Retaining Ring On Reverse Shift Lever
Courtesy of GENERAL MOTORS CORP.

32. Move the reverse shift lever and the shift shaft to the NEUTRAL position.
33. Install a new retaining ring for the reverse shift lever on the reverse shift shaft.

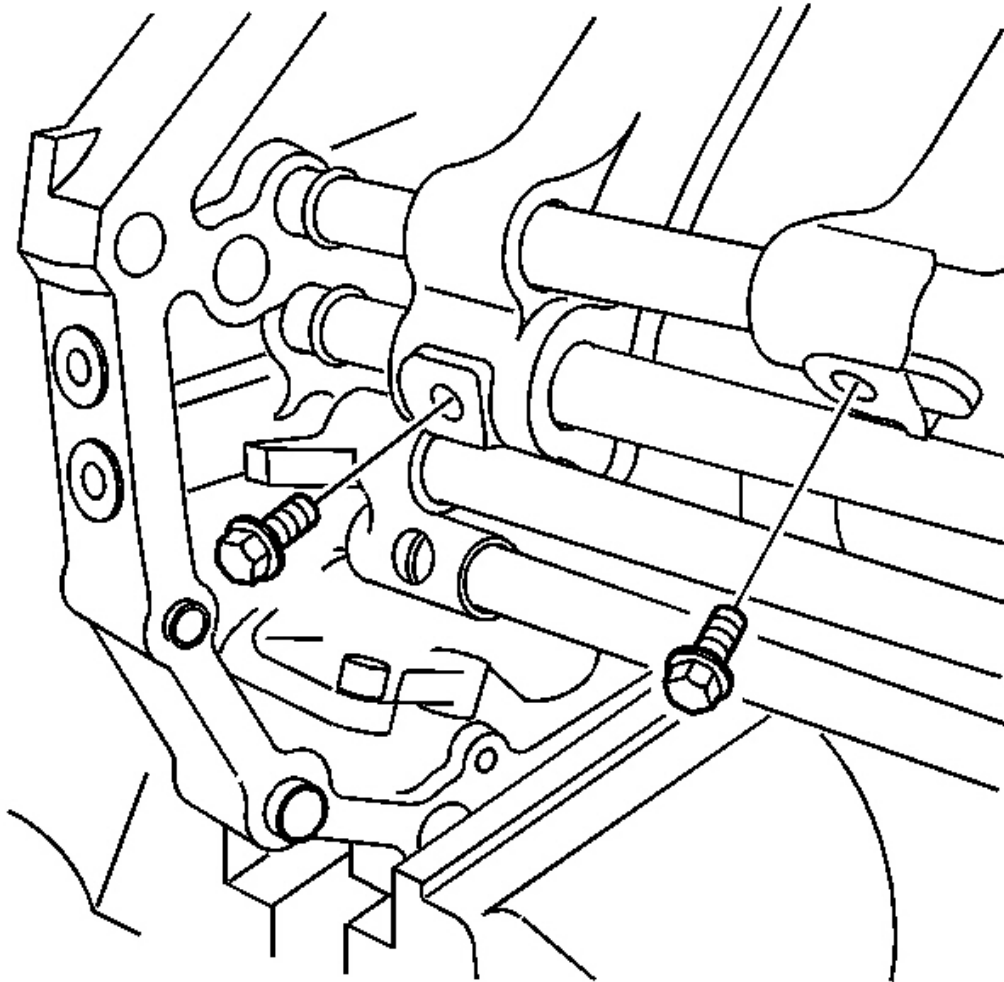

Fig. 252: Identifying Shift Fork Bolts
Courtesy of GENERAL MOTORS CORP.

IMPORTANT: The shift fork bolts must not be used again. Always install new shift fork bolts.

34. Install the 1st/2nd shift fork bolt.
35. Install the 3rd/4th shift fork bolt.

Tighten: Tighten the shift fork bolts to 20 N.m (14 lb ft).

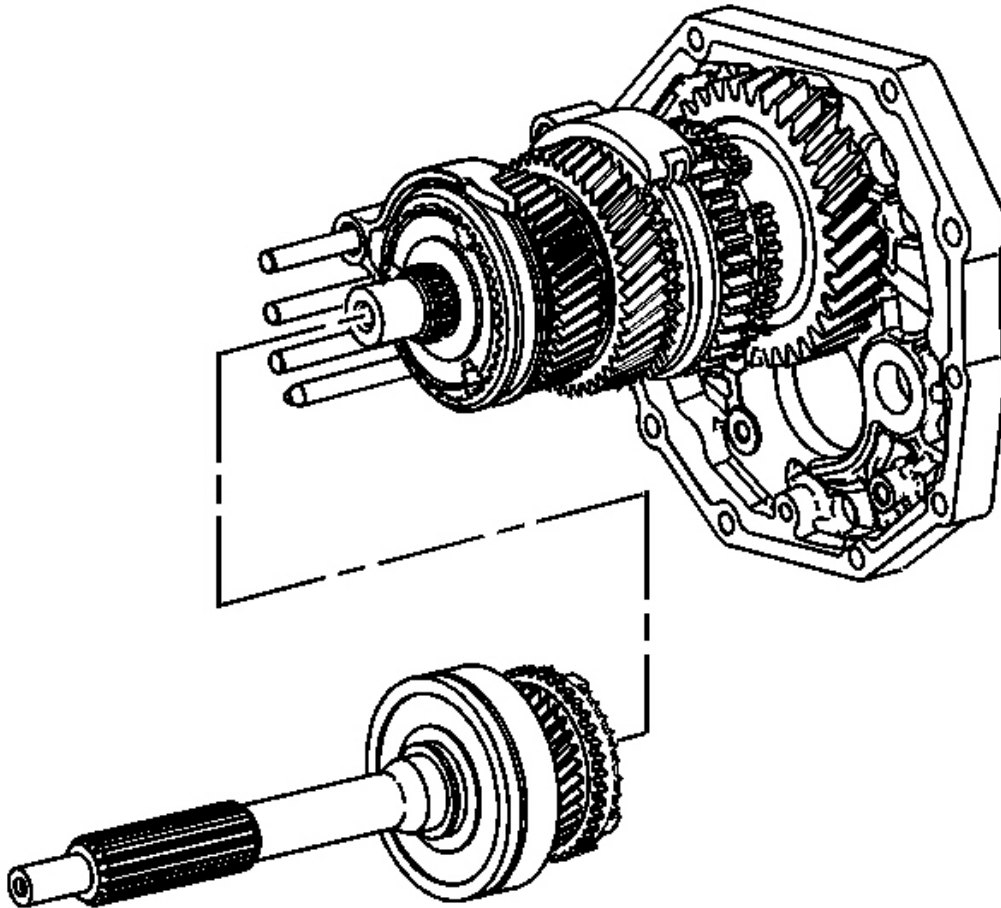

Fig. 253: View Of Input Shaft Assembly
Courtesy of GENERAL MOTORS CORP.

36. Install the input shaft assembly, with the output shaft front support bearing and the 4th gear blocking ring, to the output shaft. Ensure to align the tabs on the blocking ring to the notches in the synchronizer hub.

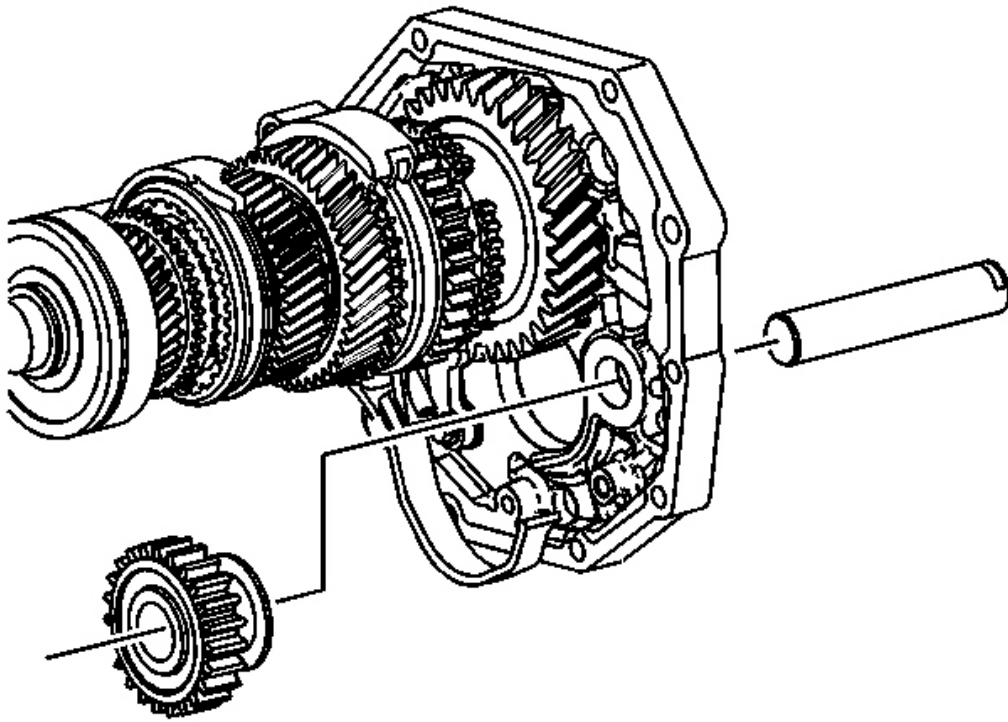

Fig. 254: Locating Reverse Gear Idler Shaft & Reverse Idler Gear
Courtesy of GENERAL MOTORS CORP.

37. Install the reverse gear idler shaft and reverse idler gear.
 - Ensure the reverse shift fork is in position on the reverse gear.
 - The slot on the reverse gear idler shaft aligns facing upward.

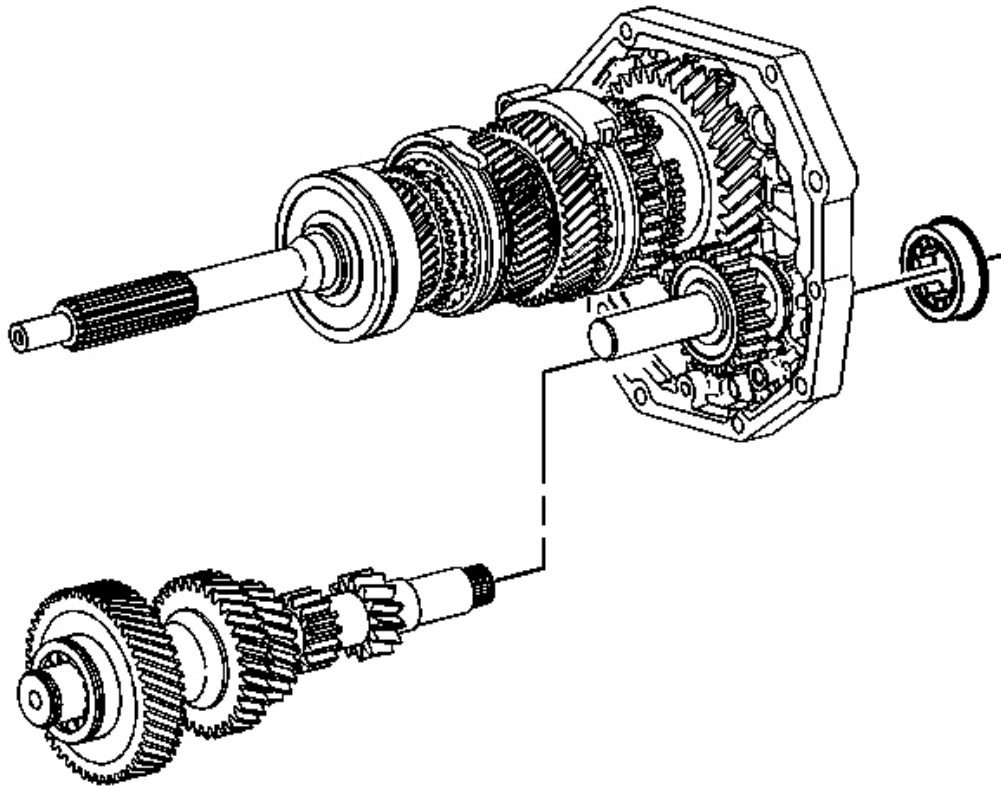

Fig. 255: View Of Countershaft & Rear Bearing
Courtesy of GENERAL MOTORS CORP.

38. Install the countershaft in position.
39. Install the countershaft rear bearing. Hold the countershaft in the correct position against the output shaft gears. The bearing will slide in the case.

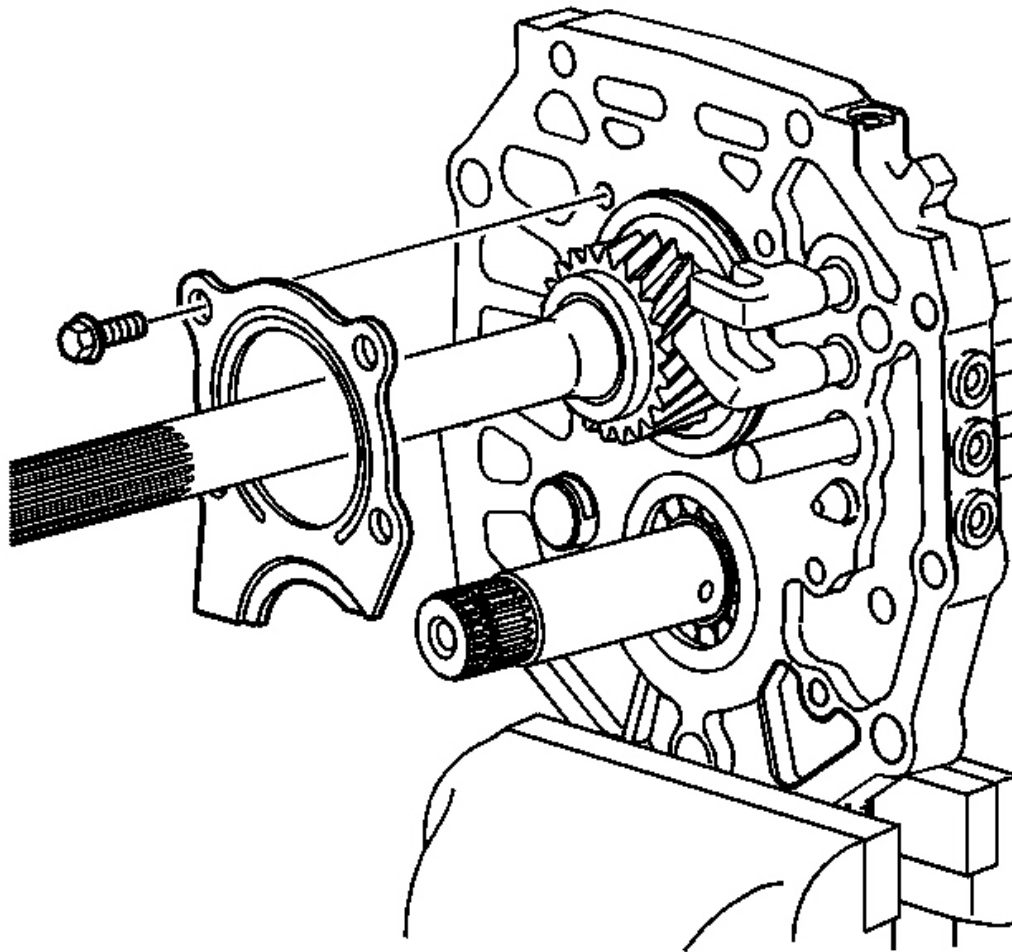

Fig. 256: Identifying Rear Bearing Retainer & Retaining Bolts
Courtesy of GENERAL MOTORS CORP.

40. Install the rear bearing retainer. The retainer installs in the slot on the reverse gear idler shaft.

IMPORTANT: New bolts are not reusable. New bolts must be used when the transmission is re-assembled.

41. Install NEW rear bearing retainer bolts.

Tighten: Tighten the retainer bolts to 25 N.m (138 lb ft).

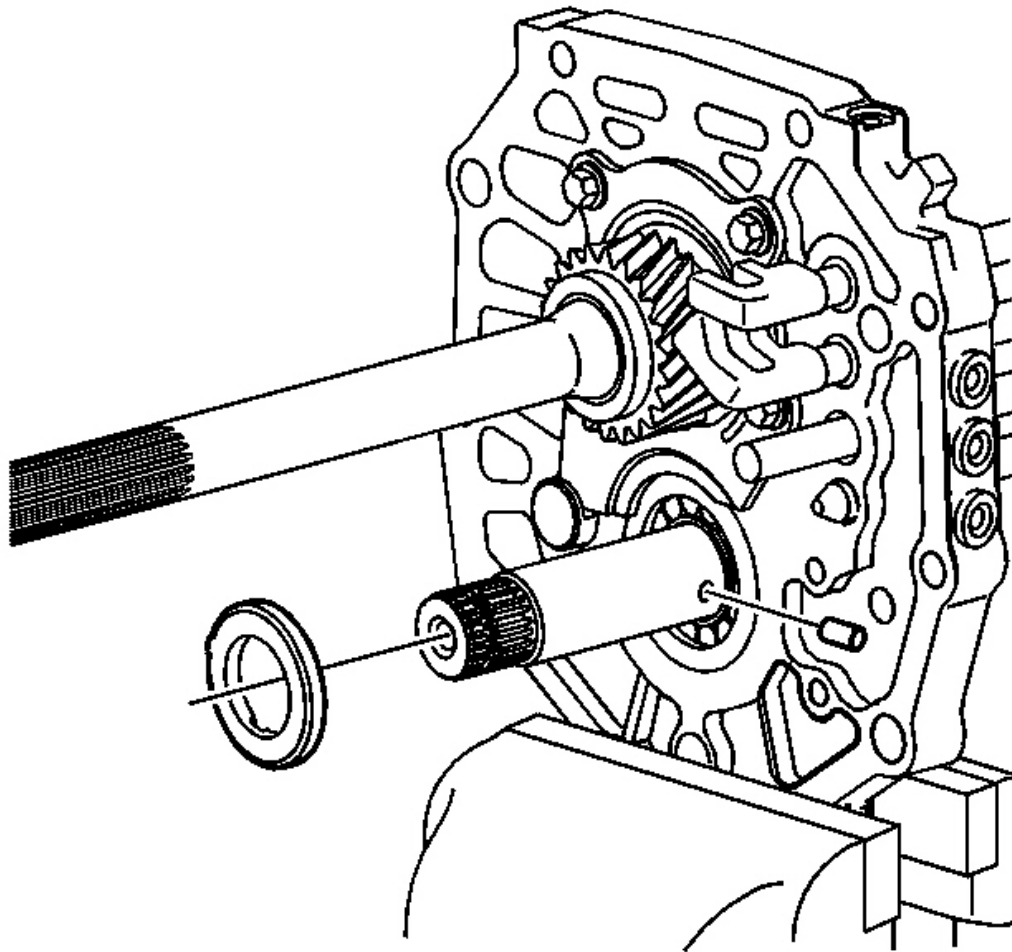

Fig. 257: Locating 5th Gear Thrust Washer
Courtesy of GENERAL MOTORS CORP.

42. Install the thrust washer lock pin.
43. Install the 5th gear thrust washer. The tapered edge side of the thrust washer goes toward the countershaft bearing.

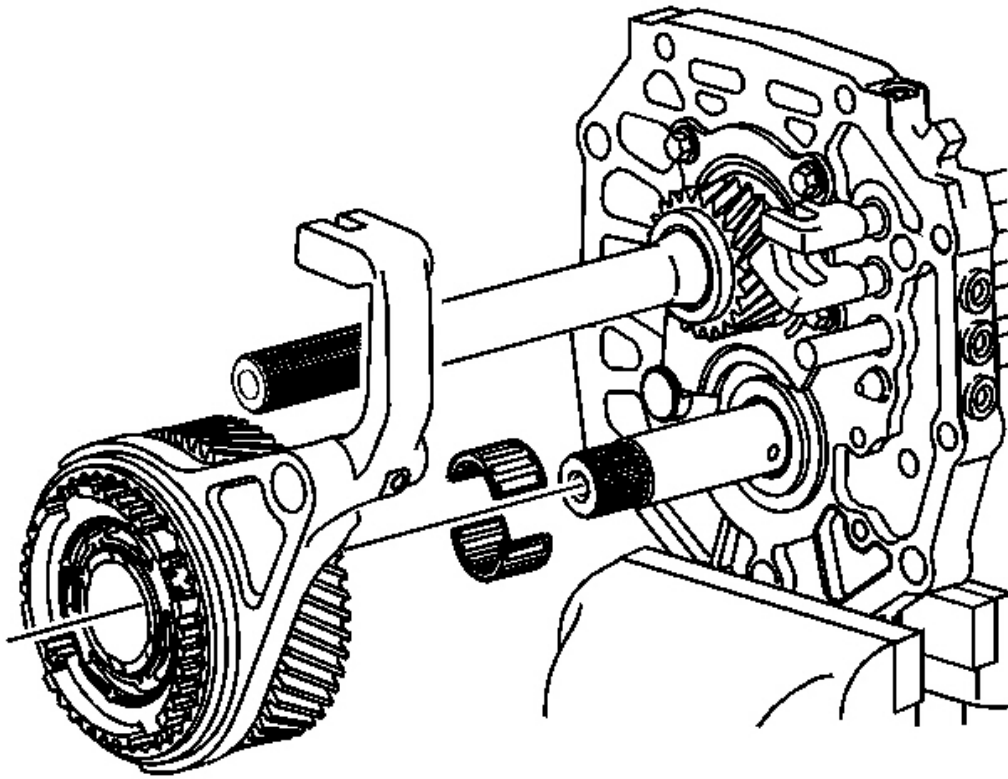

Fig. 258: View Of 5th/Reverse Synchronizer Assembly & 5th Countershaft Gear Bearing

Courtesy of GENERAL MOTORS CORP.

44. Install the 5th countershaft gear bearing and 5th/reverse synchronizer assembly onto the countershaft.

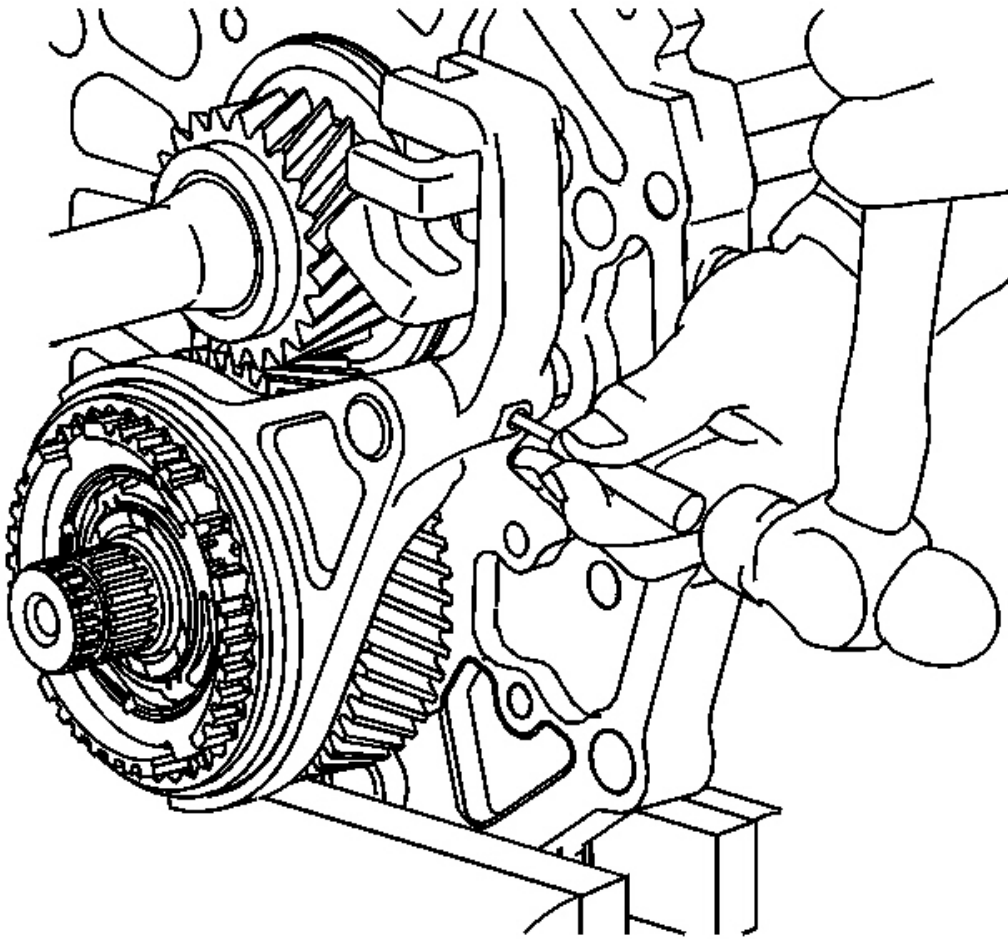

Fig. 259: Removing/Installing 5th Shift Fork Roll Pin
Courtesy of GENERAL MOTORS CORP.

45. Using a hammer and a punch, install a new 5th shift fork roll pin.

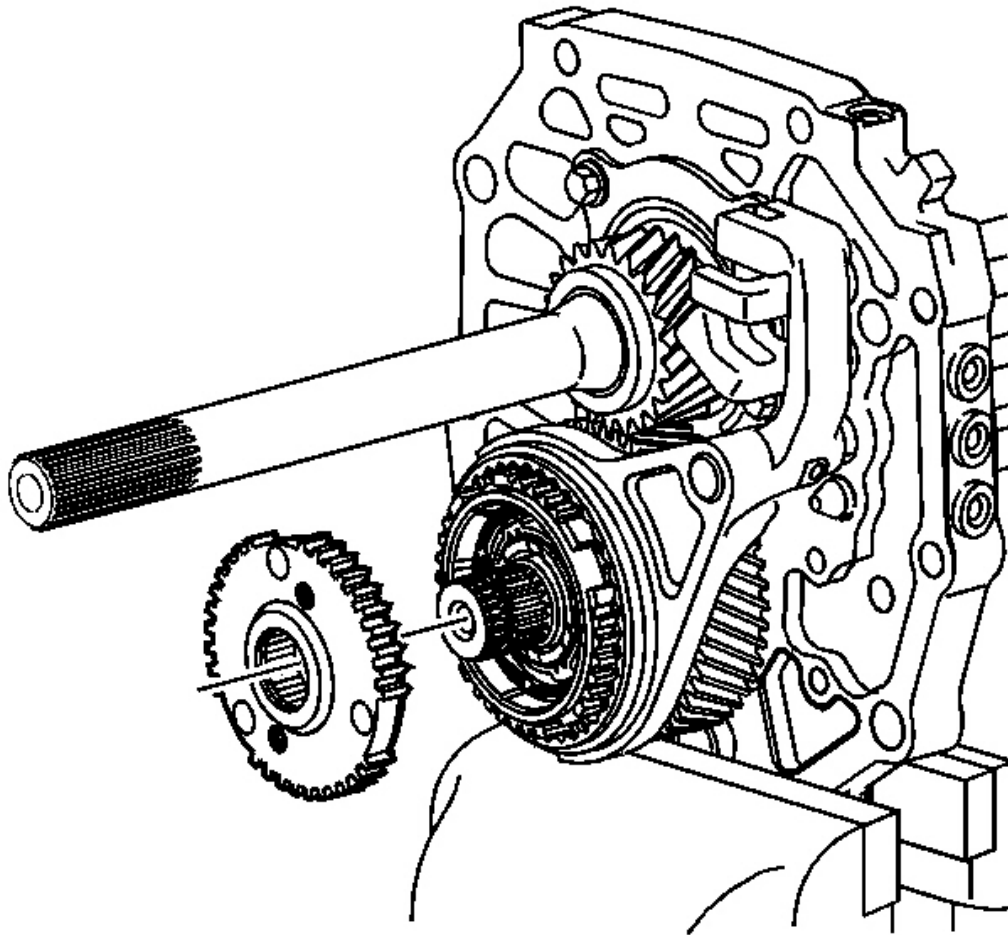

Fig. 260: Placing 5th Synchronizer Gear In Position
Courtesy of GENERAL MOTORS CORP.

IMPORTANT: When installing the 5th synchronizer gear, ensure to align with the holes for the reverse internal blocking ring tabs. Do not rotate the blocking rings to align with the gear. Rotating the blocking rings would move the rings from the lock position. If the rings become unlocked, the 5th/reverse synchronizer would have to be removed and assembled again.

46. Place the 5th synchronizer gear on the countershaft in the following position:

- The holes in the gear align with the tabs on the reverse internal blocking ring.
- The machined side of the hub goes forward, the cut point teeth side forward.

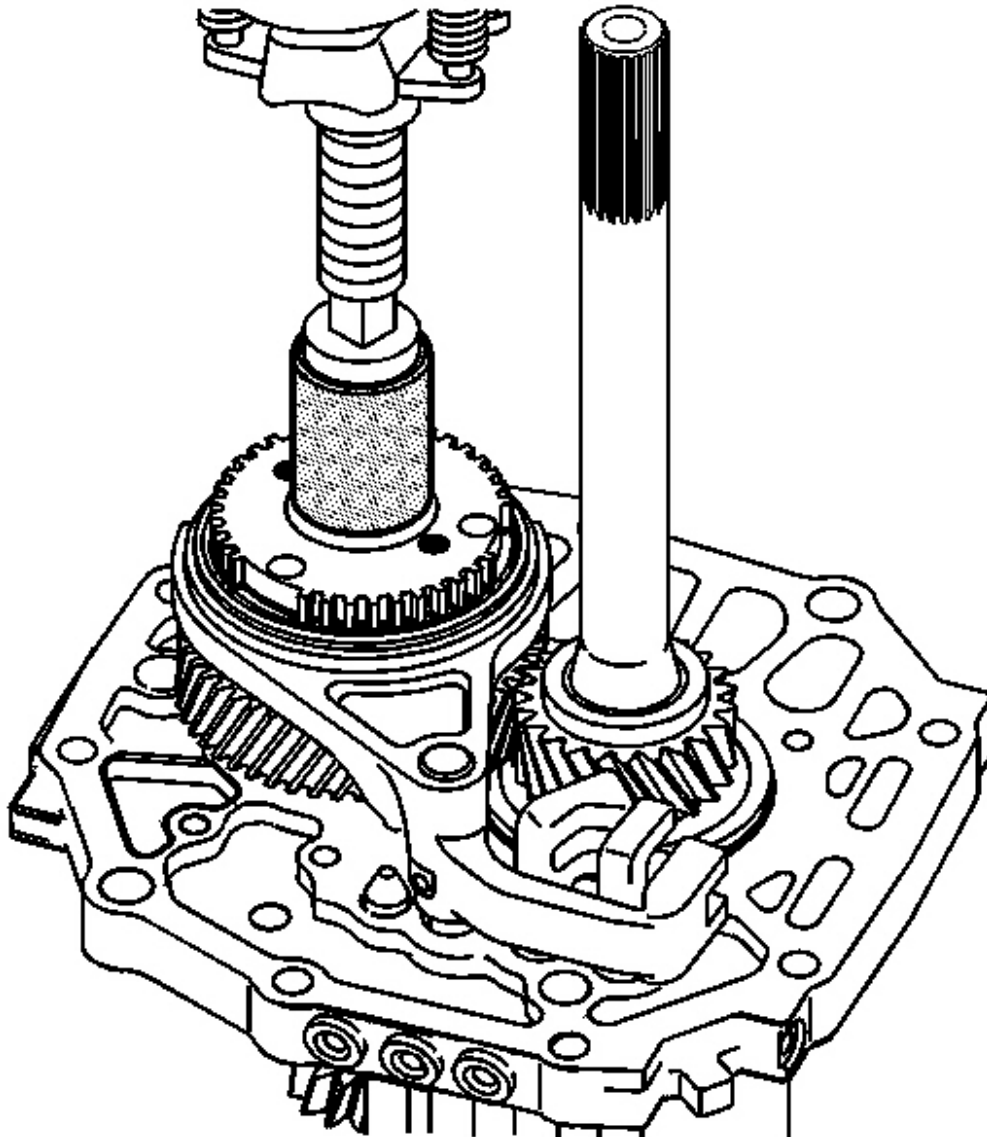

Fig. 261: View Of 5th Synchronizer Gear
Courtesy of GENERAL MOTORS CORP.

IMPORTANT: Support the front of the countershaft on a press plate. Ensure that the tabs on the blocking ring align in the gear holes. Do not rotate the blocking rings for aligning.

47. Using a hydraulic press and **J 39924-2** or equivalent, install the 5th synchronizer gear. See **Special Tools**.
48. Inspect the 5th/reverse synchronizer assembly for proper installation. The blocking rings should move freely back and forth. If the blocking rings do not move, the rings came out of the lock position. Disassembly is required. Assemble again properly.

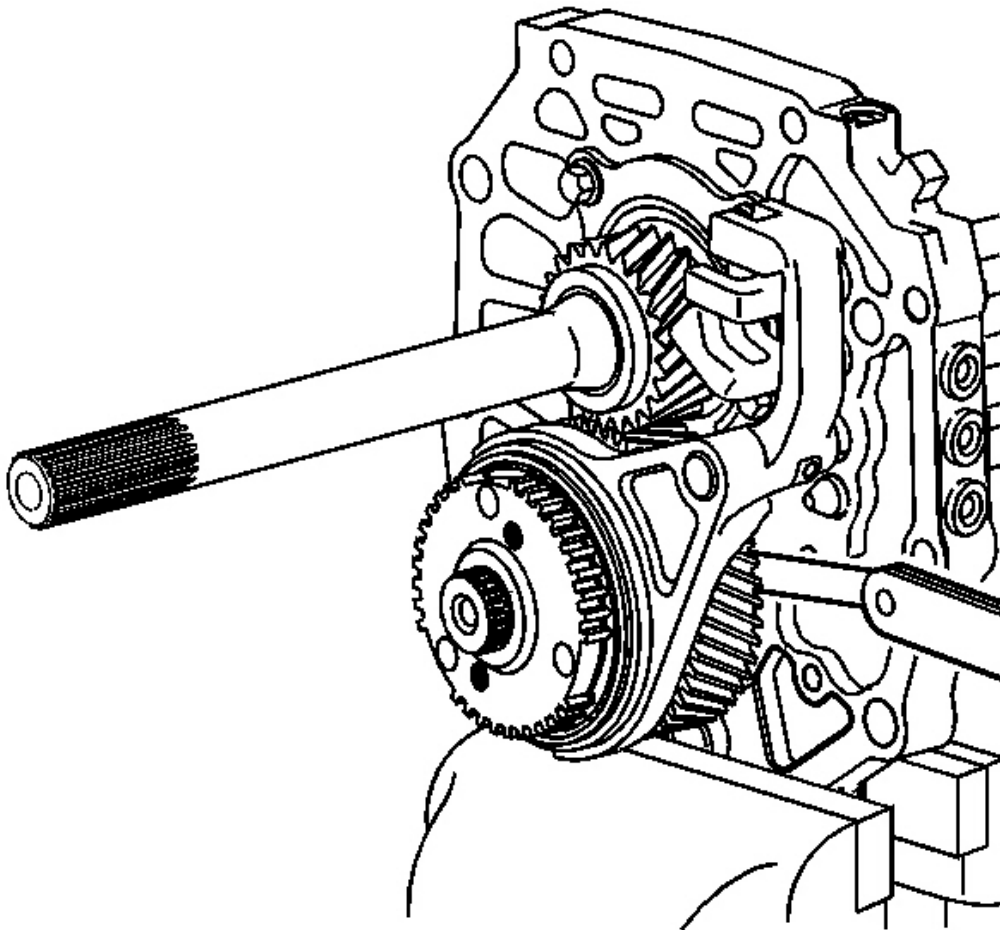

Fig. 262: Measuring Axial Clearance On 5th Gear & Thrust Washer

Courtesy of GENERAL MOTORS CORP.

49. Using a feeler gage between the 5th gear and the thrust washer, measure the axial clearance.

Specification:

- Standard Clearance: 0.10-0.35 mm (0.0039-0.0138 in)
- Maximum Clearance: 0.40 mm (0.0157 in)

50. If the clearance exceeds the maximum, ensure the 5th synchronizer gear is installed completely.

51. If the clearance exceeds the maximum, inspect the 5th countershaft gear, the countershaft or the thrust washer for wear.

52. If clearance is lower than the standard clearance, inspect the 5th countershaft gear, the countershaft or the 5th synchronizer gear for burrs.

53. Repair or replace the damaged or worn component.

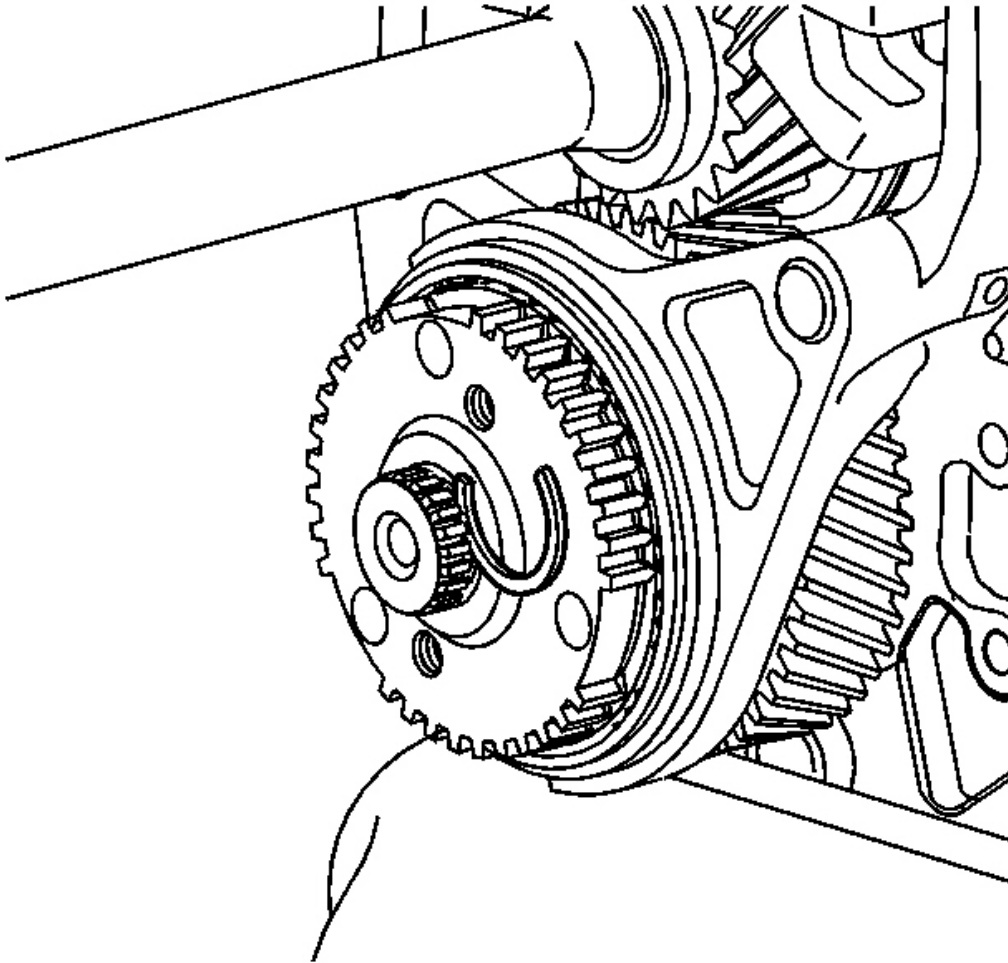

Fig. 263: Identifying 5th Synchronizer Gear Retaining Ring
Courtesy of GENERAL MOTORS CORP.

IMPORTANT: The retaining ring is a select fit. Always install a **NEW** retaining ring.

54. Select the maximum thickness retaining ring for the 5th gear, that will fit. Refer to **Fifth Gear Retaining Ring Specifications**.
55. Install the 5th synchronizer gear retaining ring.

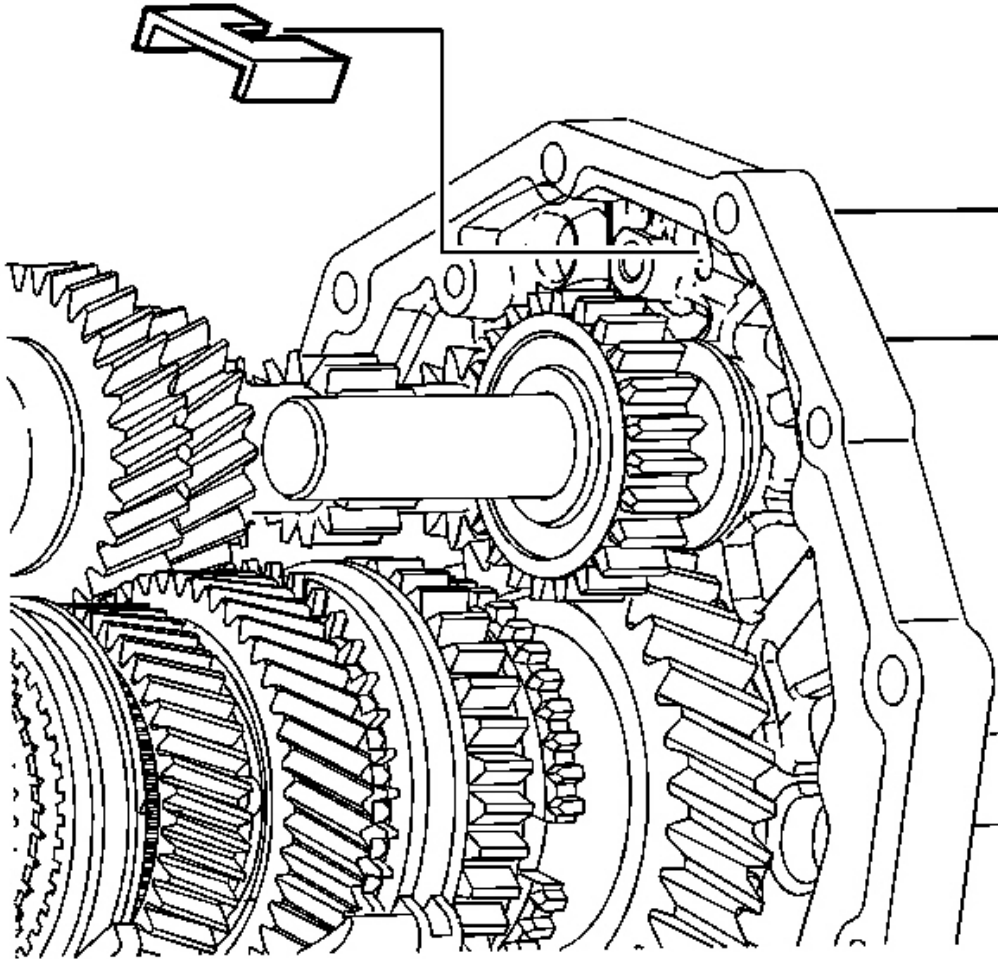

Fig. 264: View Of Transmission Magnet
Courtesy of GENERAL MOTORS CORP.

56. Install the magnet.

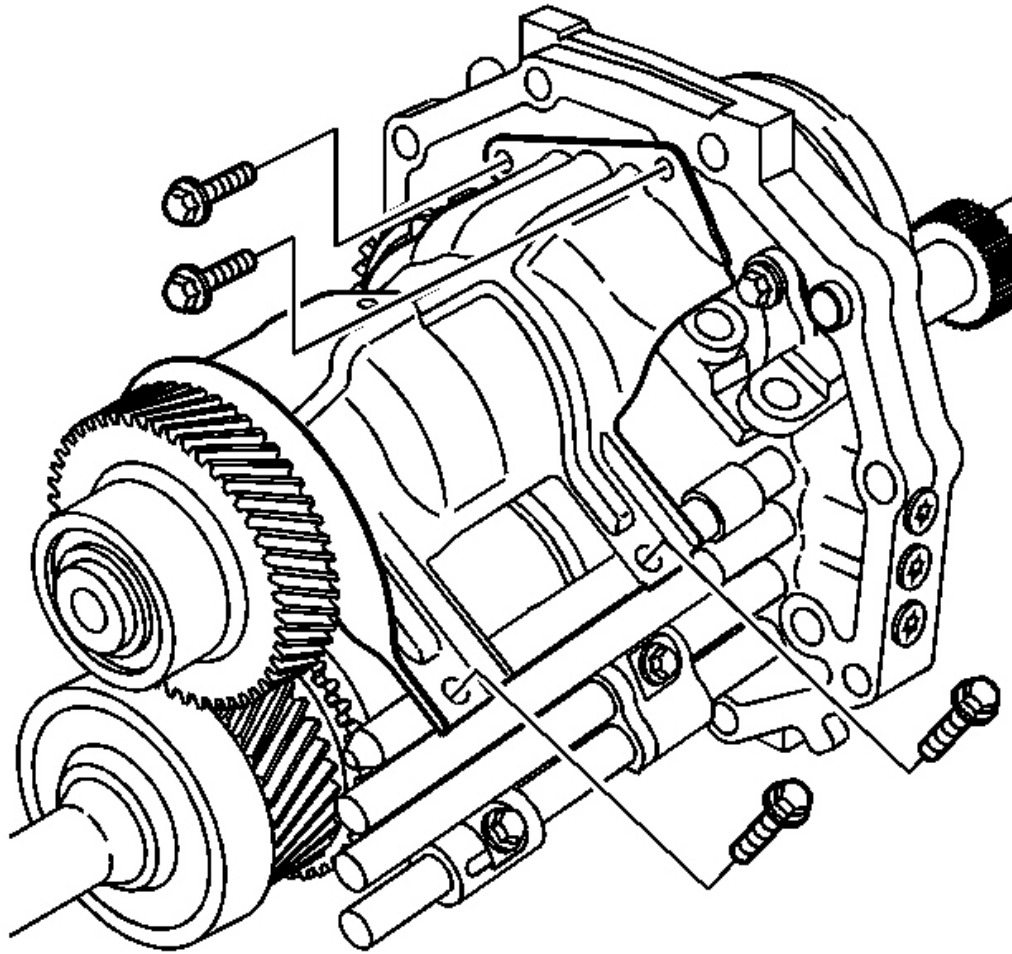

Fig. 265: Locating Oil Baffle Bolts
Courtesy of GENERAL MOTORS CORP.

57. Apply threadlocker GM P/N 12345382 (Canadian P/N 10953489) to the threads of the oil baffle bolts.
58. Install the oil baffle.
59. Install the oil baffle bolts.

Tighten:

- Tighten the oil baffle bolts to the intermediate case to 20 N.m (14 lb ft).
- Tighten the oil baffle bolts to the shift shaft to 13 N.m (10 lb ft).

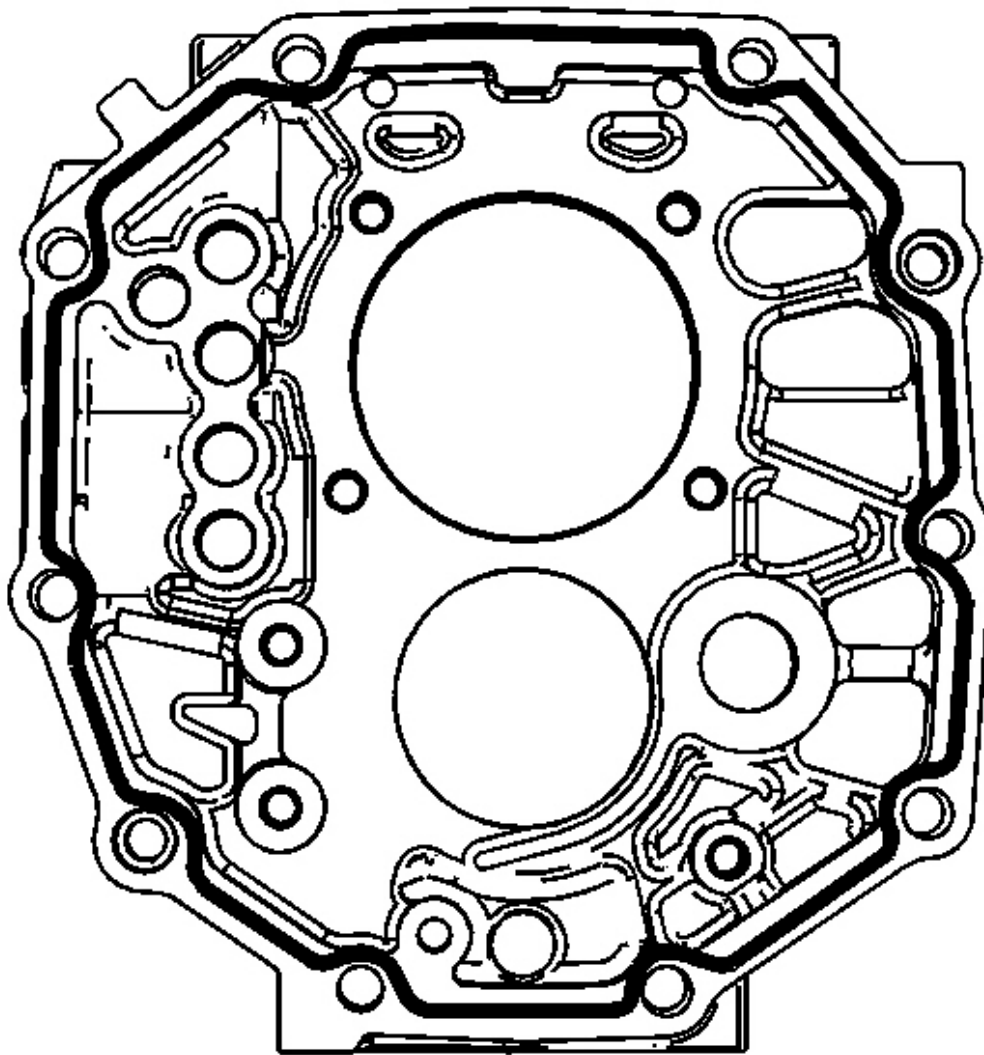

Fig. 266: Sealant Application Areas On Intermediate Case
Courtesy of GENERAL MOTORS CORP.

60. Apply a 3 mm (1/8 in) bead of sealant GM P/N 89020326 (Canadian P/N 89021188) to the front of the intermediate case.

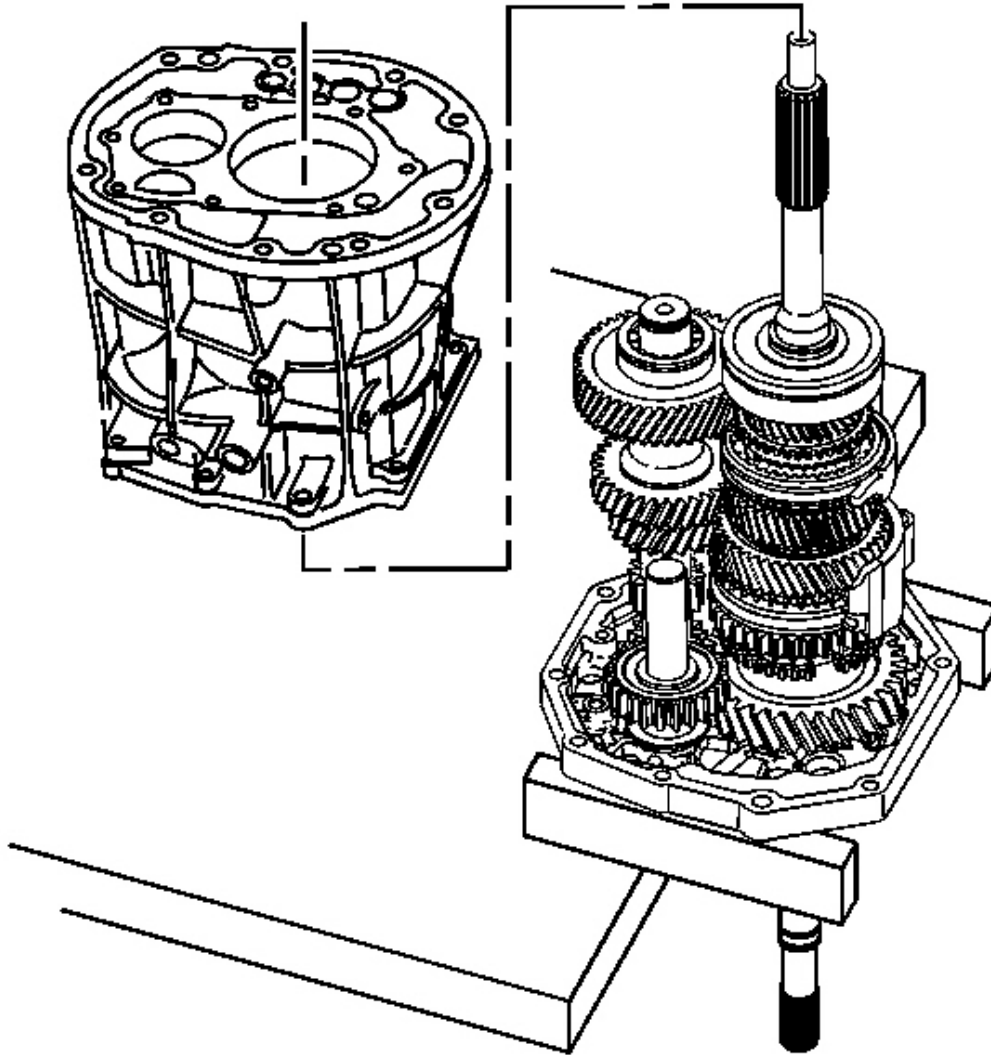

Fig. 267: View Of Transmission Case
Courtesy of GENERAL MOTORS CORP.

61. Support the intermediate case on wooden blocks, with the output shaft over the edge of a workbench, to allow installation of the transmission case.

IMPORTANT: The 4th blocking ring may have moved out of position. The 4th blocking ring tabs should be seated in the notches of the

3rd/4th synchronizer hub.

62. Install the transmission case to the intermediate case.
 - Ensure the 4th blocking ring is seated properly.
 - Ensure the location pins are installed.
 - Slide the transmission case over the shift rails.
 - Use a soft-face hammer to install the transmission case completely to the intermediate case.
 - Do not let the sealer air dry.

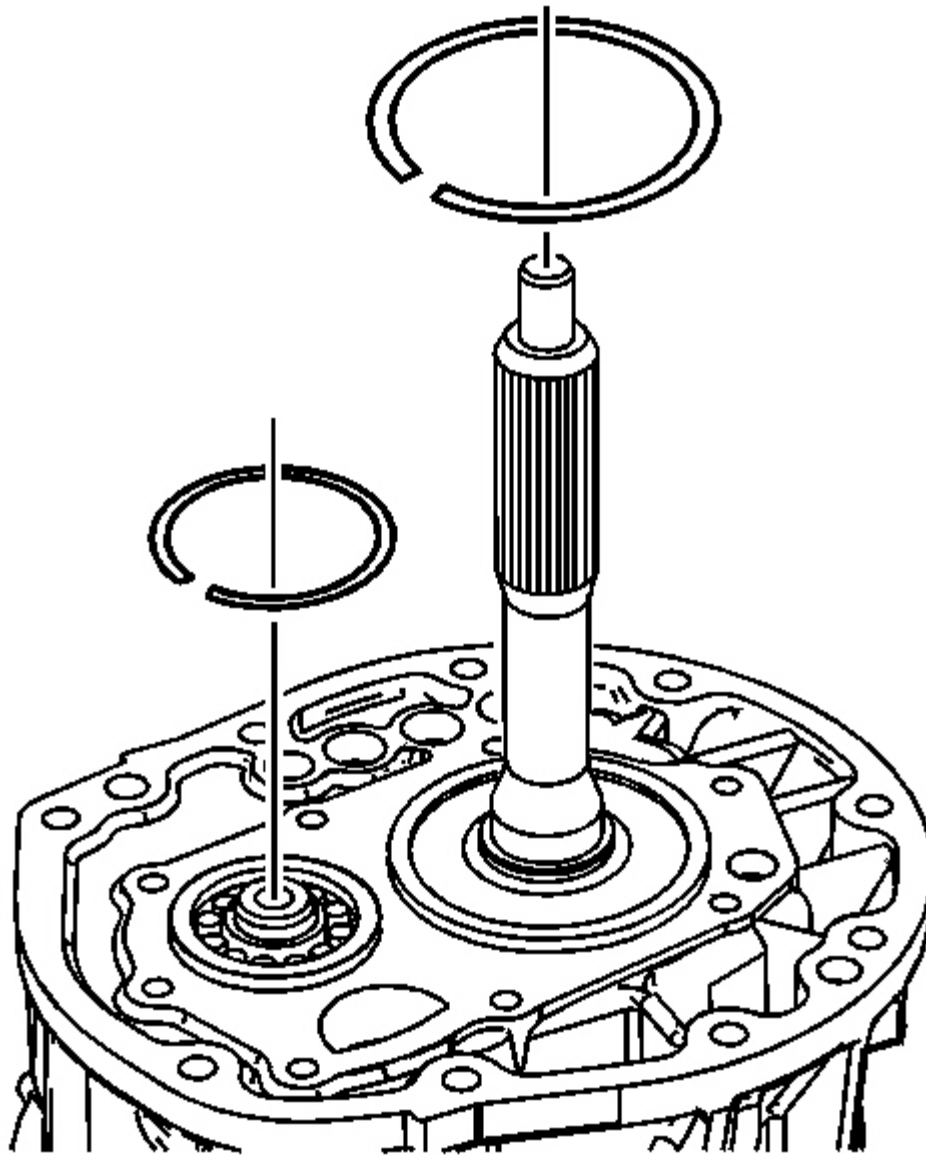

Fig. 268: Locating Outer Retaining Rings On Input Shaft Bearing & Countershaft Front Bearing
Courtesy of GENERAL MOTORS CORP.

63. Install the countershaft front bearing outer retaining ring. It may be necessary to lift up the countershaft in order to install the retaining ring.

64. Install the input shaft bearing outer retaining ring. If the retaining ring will not seat flush to the case, the 4th blocking ring was not in the correct position.

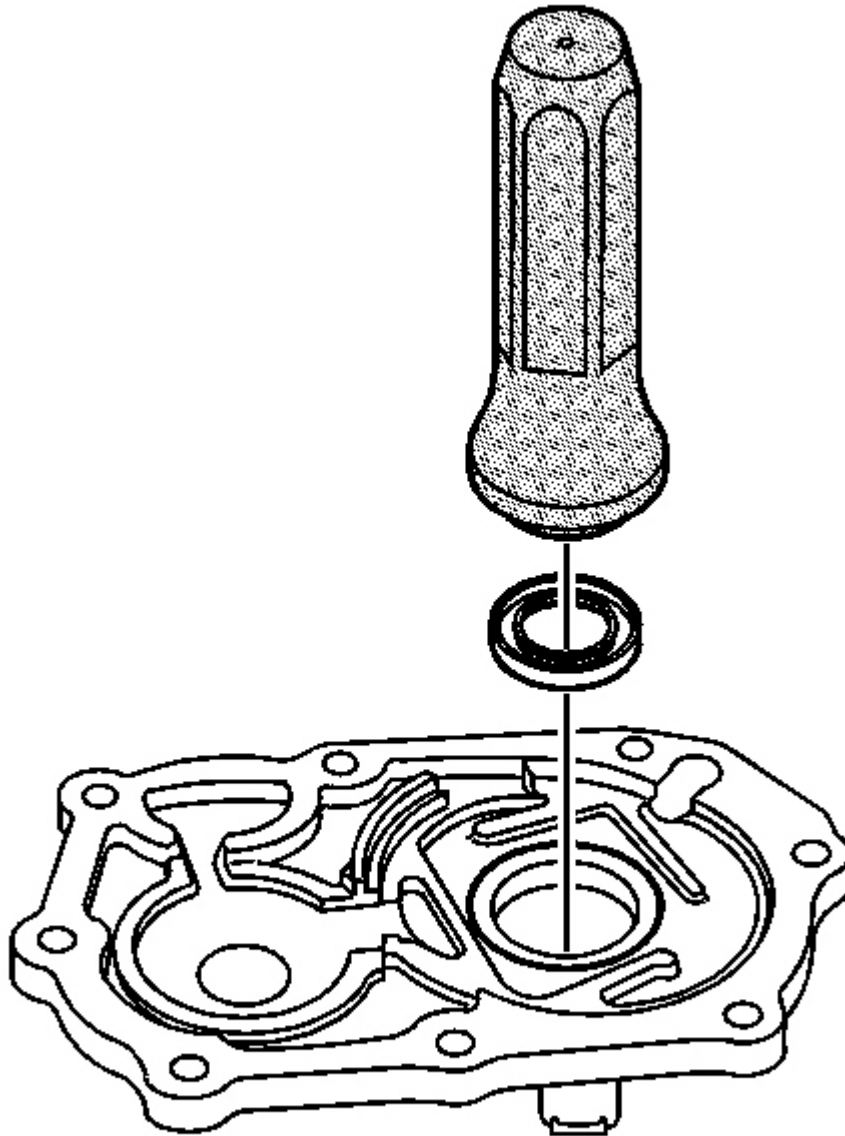

Fig. 269: View Of Input Shaft Seal
Courtesy of GENERAL MOTORS CORP.

65. Using **J 45866** , install a new input shaft seal in the input shaft bearing retainer. See **Special Tools**.

- The spring side of the seal goes toward the tool.
- Ensure the seal is installed square.
- The tool will install the seal to the correct depth.

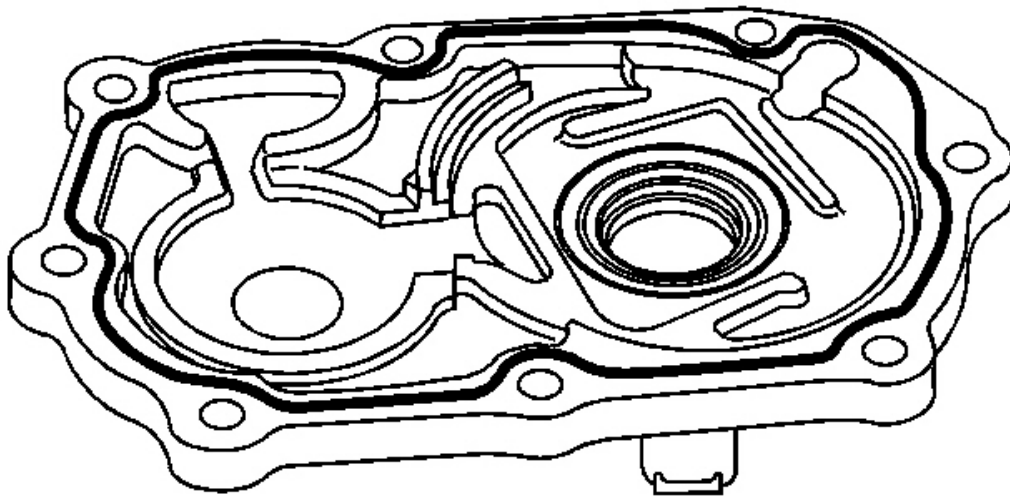

Fig. 270: Sealant Area On Input Shaft Bearing Retainer
Courtesy of GENERAL MOTORS CORP.

66. Apply a 3 mm (1/8 in) bead of sealant GM P/N 89020326 (Canadian P/N 89021188) to the input shaft bearing retainer.

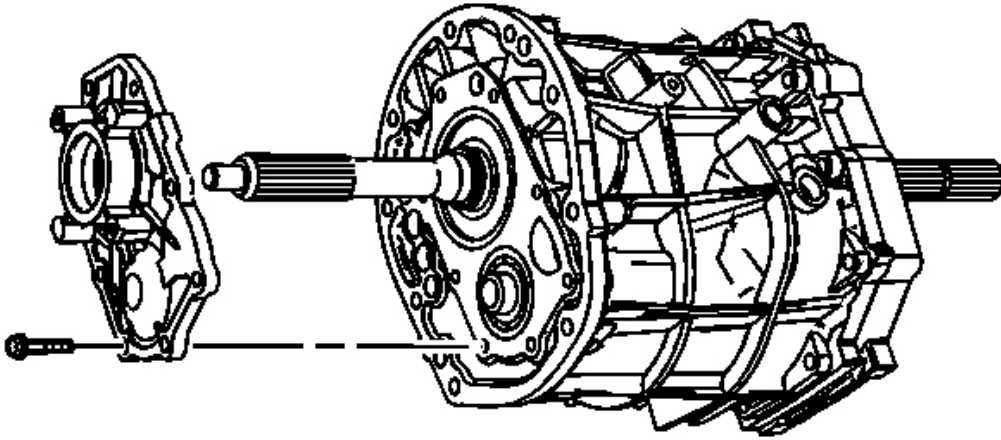

Fig. 271: Locating Input Shaft Bearing Retainer Bolts
Courtesy of GENERAL MOTORS CORP.

IMPORTANT: Ensure the seal is not caught on the input shaft.

67. Install the input shaft bearing retainer.

IMPORTANT: The input shaft bearing retainer bolts must not be used again. Always install new retainer bolts.

68. Install the bearing retainer bolts.

Tighten: Tighten the bearing retainer bolts to 17 N.m (12 lb ft).

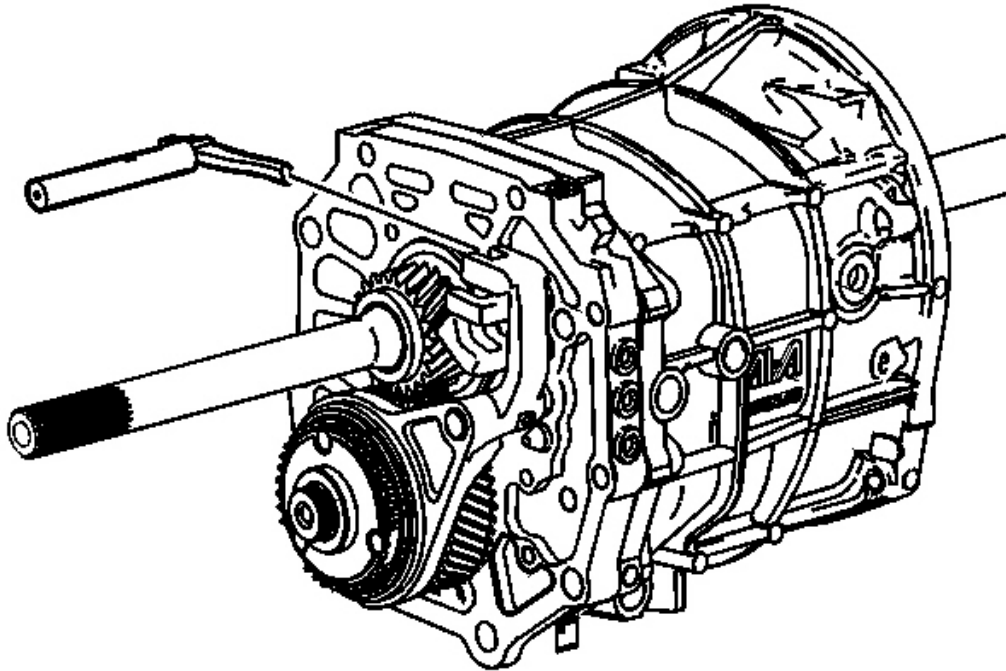

Fig. 272: Identifying Shift Control Shaft
Courtesy of GENERAL MOTORS CORP.

69. Install the shift control shaft in the shift shaft gates.

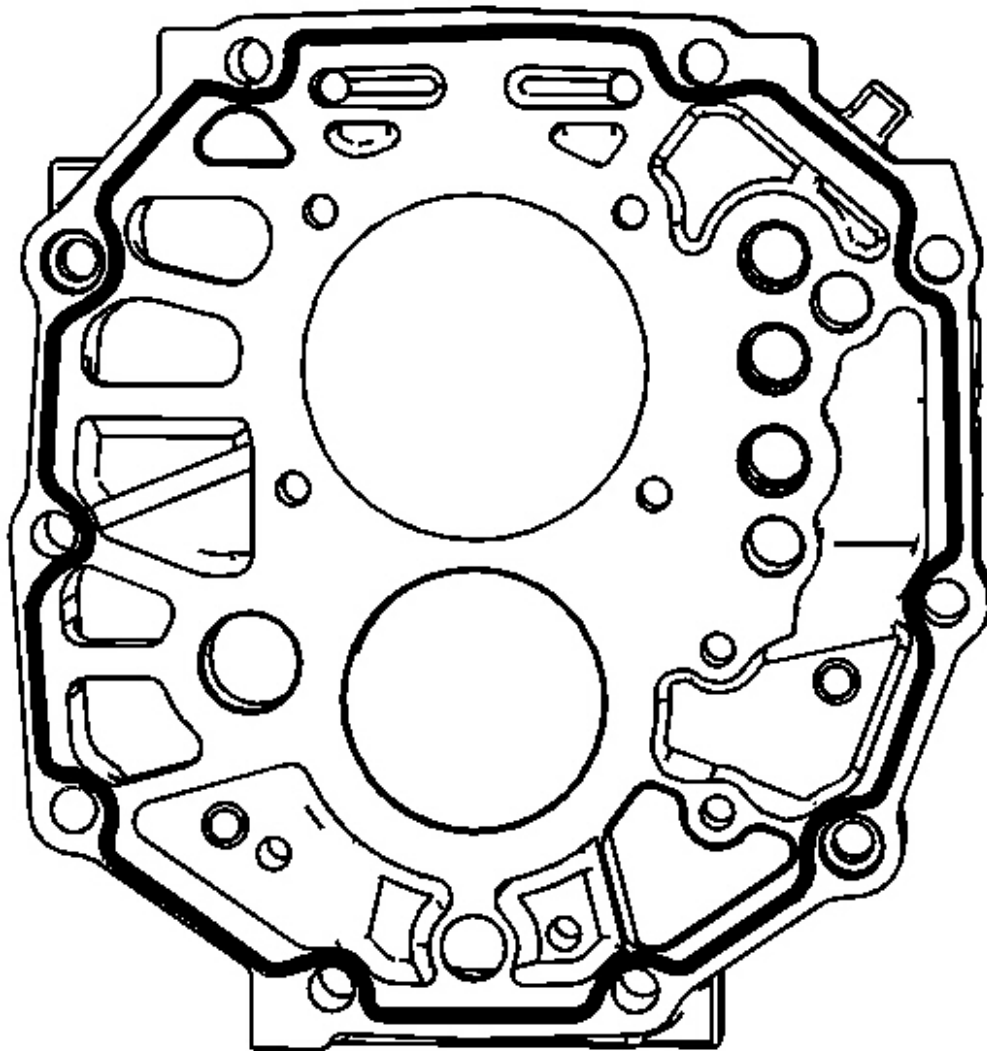

Fig. 273: Application Areas On Rear Of Intermediate Case
Courtesy of GENERAL MOTORS CORP.

70. Apply a 3 mm (1/8 in) bead of sealant GM P/N 89020326 (Canadian P/N 89021188) to the rear of the intermediate case.

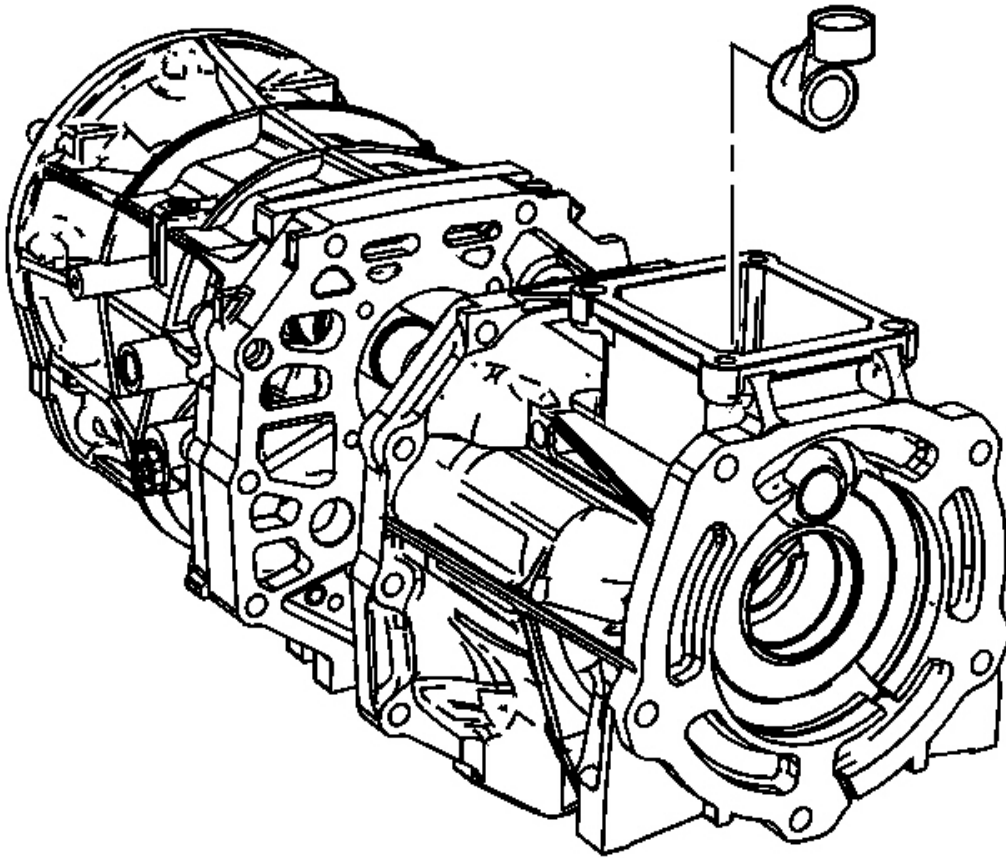

Fig. 274: Locating Shift Control Socket At Extension Housing Shift Lever Cavity
Courtesy of GENERAL MOTORS CORP.

71. Install the extension housing to the intermediate case.
 - Slide the case over the shift control shaft.
 - Install the shift control socket on the shift control shaft.
 - Ensure the extension housing is installed completely to the intermediate case.
 - Use a soft-face hammer to tap the extension housing in place.

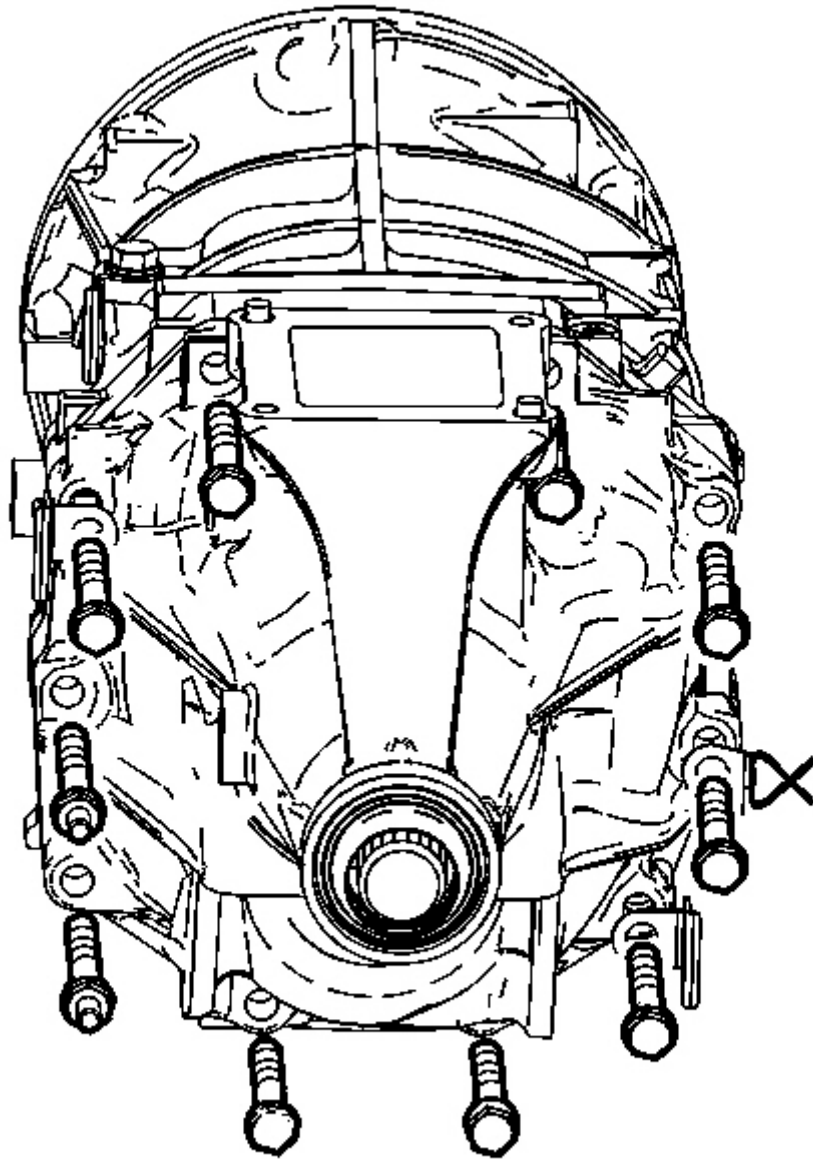

Fig. 275: Identifying Extension Housing Retaining Bolts And Studs
Courtesy of GENERAL MOTORS CORP.

72. Install the extension housing retaining bolts and studs, with the brackets, to the proper location as marked during disassembly.

Tighten: Tighten the extension housing bolt and studs to 37 N.m (27 lb ft).

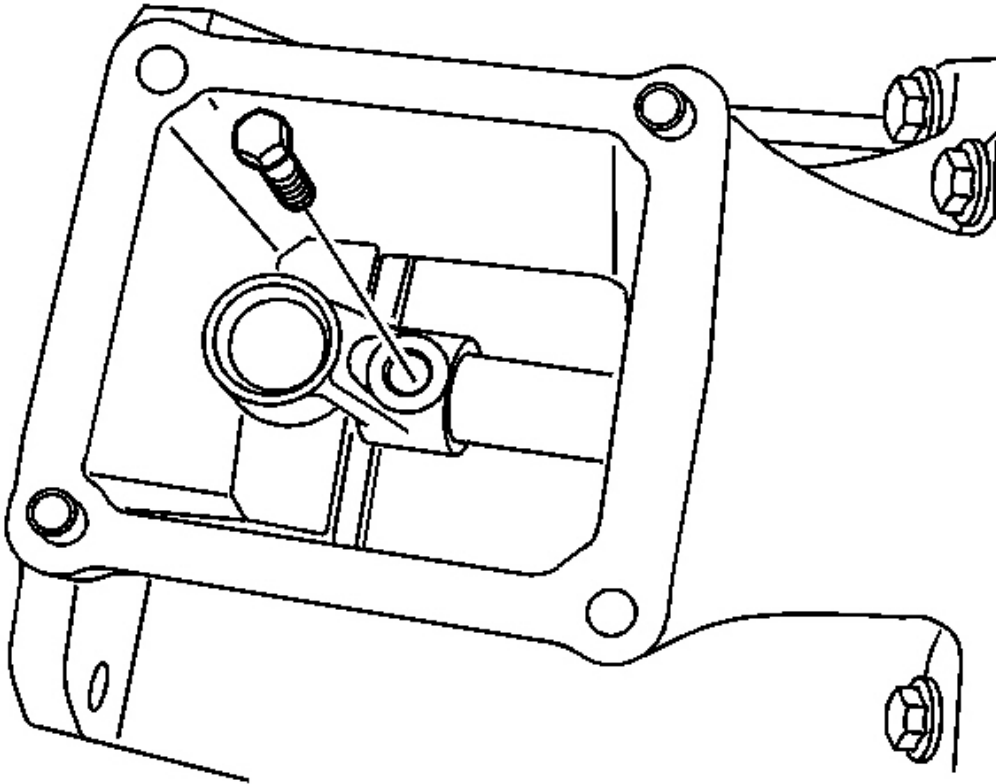

Fig. 276: View Of Shift Control Lever Socket Bolt
Courtesy of GENERAL MOTORS CORP.

IMPORTANT: Do not use the shift control lever socket bolt again. Always install a new lever socket bolt.

73. Install the control lever bolt.

Tighten: Tighten the control lever bolt to 33 N.m (24 lb ft).

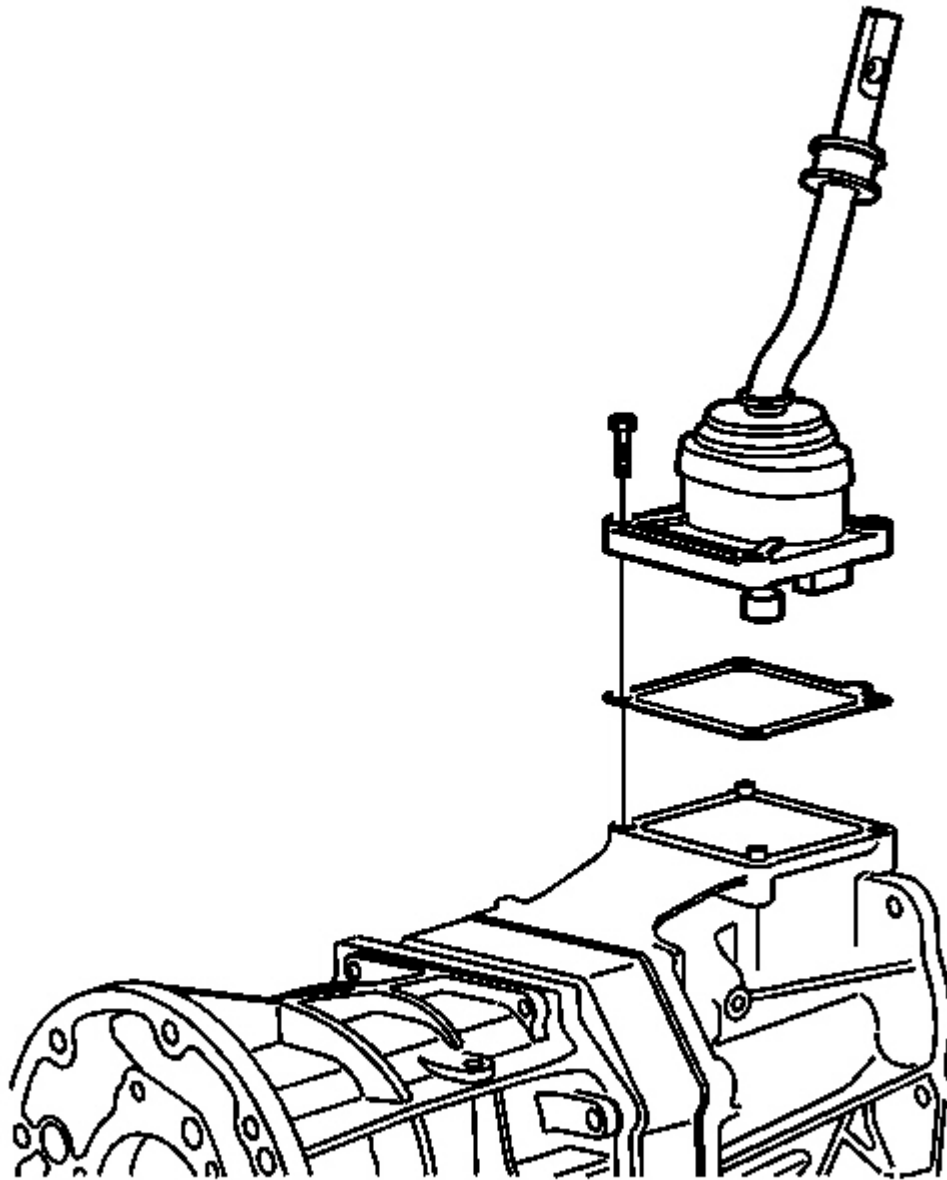

Fig. 277: Locating Shift Control Housing & Gasket
Courtesy of GENERAL MOTORS CORP.

74. Install the shift control housing with a new gasket.
75. Install the shift control housing bolts.

Tighten: Tighten the housing bolts to 20 N.m (14 lb ft).

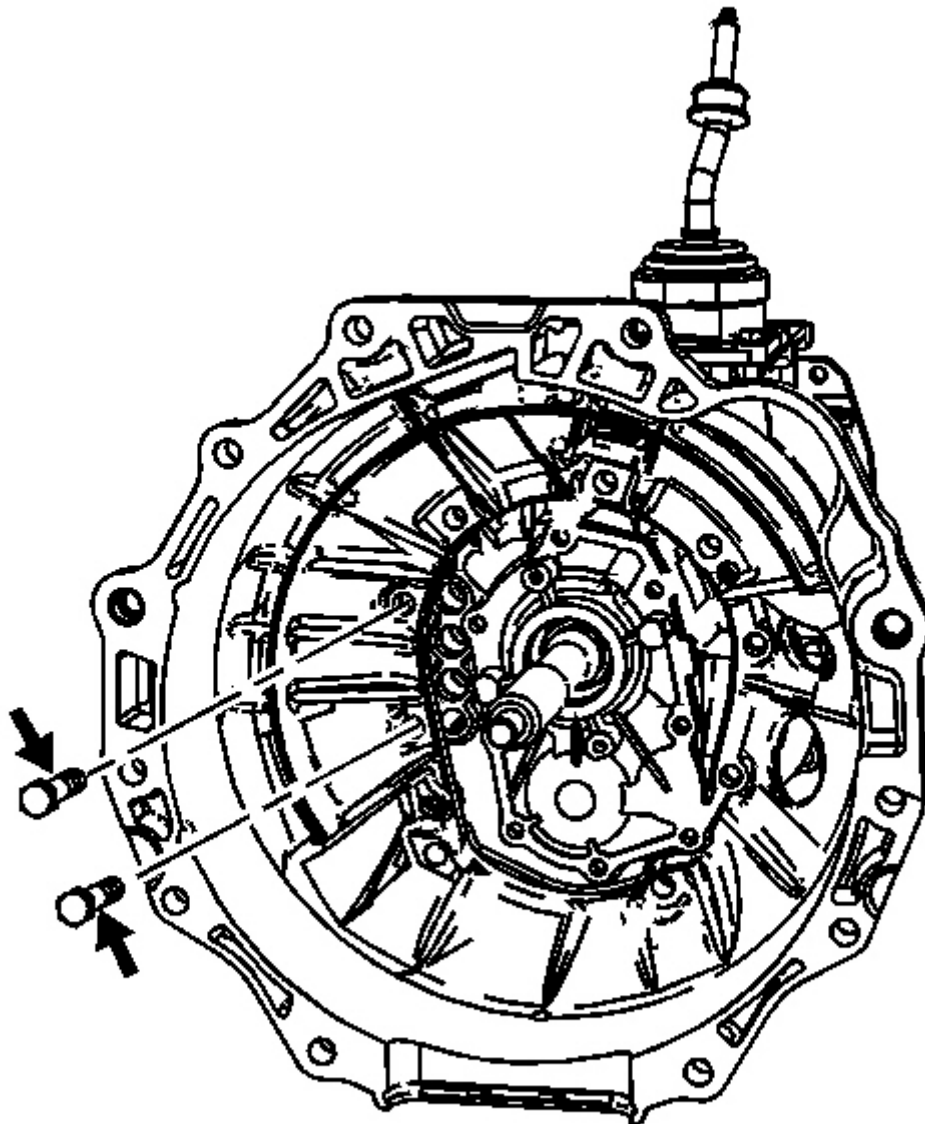

Fig. 278: Identifying Clutch Housing Bolts
Courtesy of GENERAL MOTORS CORP.

76. Using a soft-face hammer to assist, install the clutch housing to the transmission case.

IMPORTANT: Two of the clutch housing bolts require sealant. If sealant is not used, leakage will occur. Always use new bolts.

77. Install the 2 new bolts in the clutch housing location, as shown.
78. Install the remaining clutch housing bolts.

Tighten: Tighten the clutch housing bolts to 36 N.m (27 lb ft).

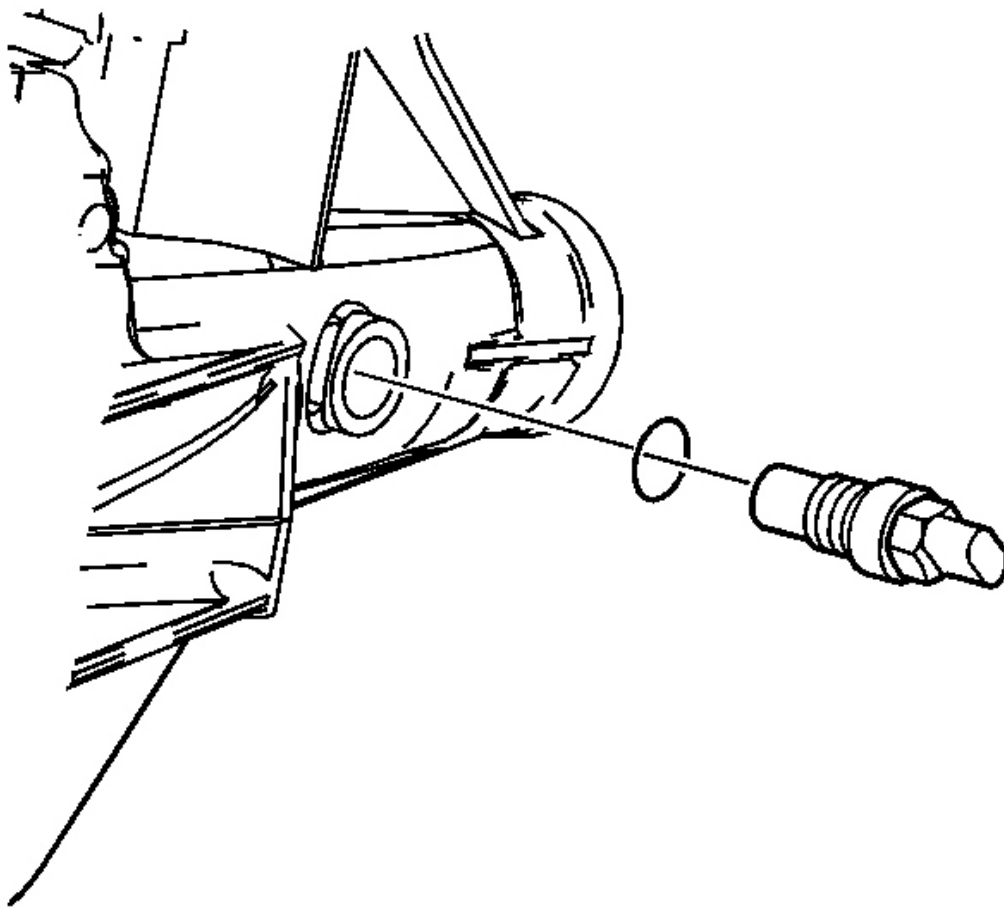

Fig. 279: View Of Vehicle Speed Sensor (VSS) With O-Ring Seal
Courtesy of GENERAL MOTORS CORP.

79. If RWD transmission, install the vehicle speed sensor (VSS) with O-ring seal.

Tighten: Tighten the VSS to 17 N.m (12 lb ft).

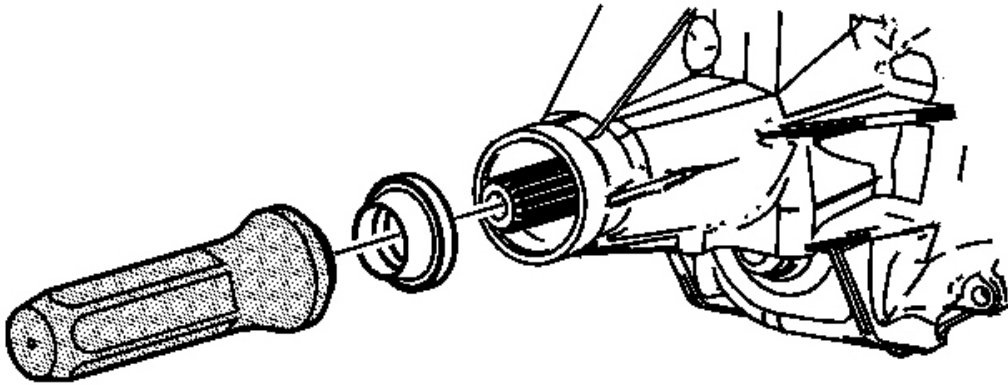

Fig. 280: Locating Output Shaft Seal - RWD
Courtesy of GENERAL MOTORS CORP.

80. If RWD transmission, using the **J 45868** , install a new output shaft seal. See **Special Tools**.

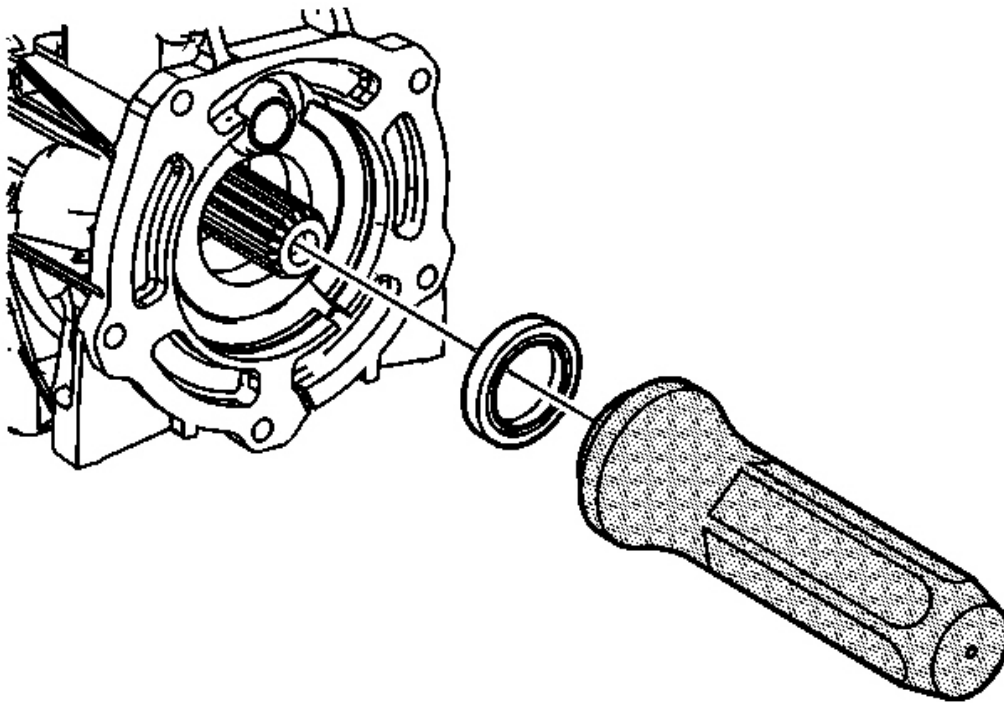

Fig. 281: Identifying Output Shaft Seal - 4WD
Courtesy of GENERAL MOTORS CORP.

81. If 4WD transmission, using the **J 45867** , install a new output shaft seal. See **Special Tools**.

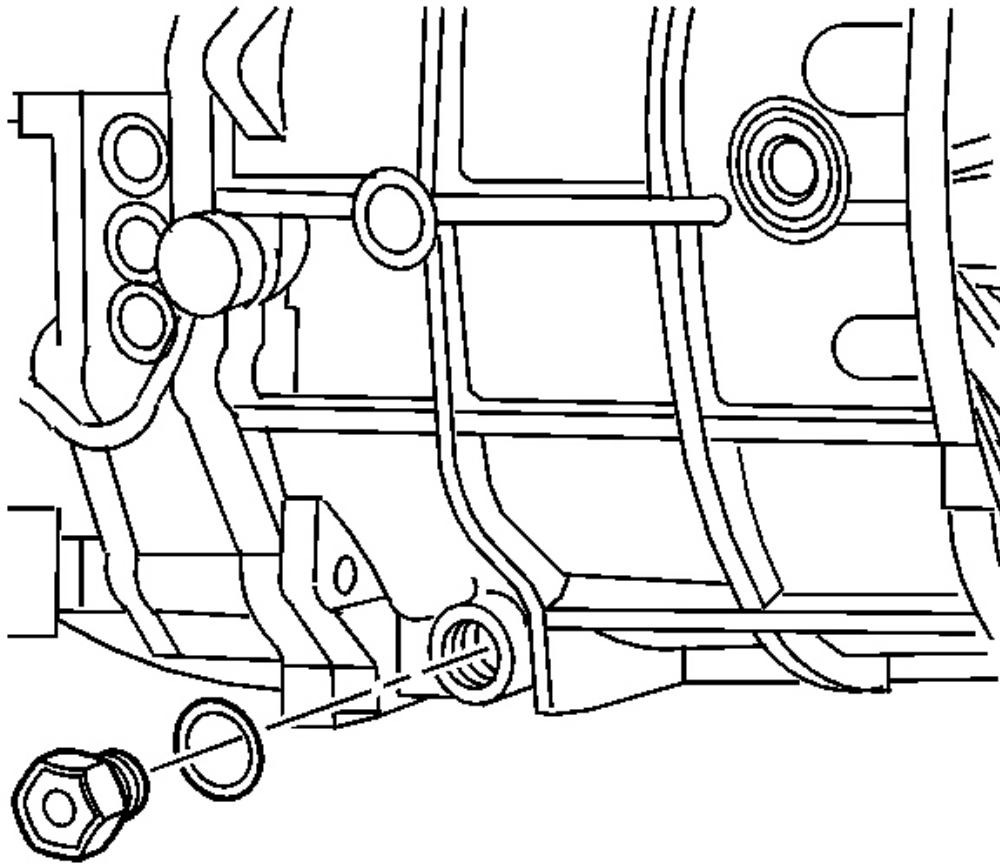

Fig. 282: View Of Drain Plug
Courtesy of GENERAL MOTORS CORP.

82. Install the drain plug with a new gasket.

Tighten: Tighten the drain plug to 37 N.m (27 lb ft).

DESCRIPTION AND OPERATION

TRANSMISSION SYSTEM DESCRIPTION AND OPERATION

General Description

The Aisin AR5 is a 5 speed transmission with 5th gear being an overdrive ratio. All gear positions

The AR5 has a unique shift system. A single shift control shaft (281) operates four shift shafts. The shift control lever (500) fits into a socket on the shift control shaft (281). Positioning the lever or finger of the shift control shaft (281), in the gates of the shift shafts, operates the 1st/2nd shift shaft (211), the 3rd/4th shift shaft (231) and the 5th shift shaft (251). Moving the shift control lever (500) side-to-side allows the lever on the shift control shaft (281) to engage into one of the three gates. Moving the shift control lever (500) forward and reverse selects either position of the particular shift shaft. The 3rd/4th shift shaft (231) is the top shift shaft. A bolt holds the 3rd/4th shift fork (230) in place on the shift shaft. When shifted in position, a detent ball (287) and spring (288) located in the top of the intermediate case, holds the shift shaft. The 1st/2nd shift shaft (211) is the second shaft from the top. A bolt holds the 1st/2nd shift fork (210) in place on the shift shaft. In addition, the 1st/2nd shift fork (210) slides on the 3rd/4th shift shaft (231). Using two shift shafts for the shift fork, keeps the shift fork square to the synchronizer sleeve. A small shift shaft interlock pin (292) in the 1st/2nd shift shaft (211) prevents the other shafts from moving. Interlock pins (291), located in the intermediate case on either side of the 1st/2nd shift shaft (231), contact the small interlock pin (292) and lock into a notch on the shift shafts, preventing multiple shift shaft movement. The 5th shift shaft (251) is located third from the top. A roll pin holds the 5th shift fork (250) in place on the shift shaft. In addition, on the 5th shift shaft (251) is the reverse shift lever (274). The reverse shift shaft (271) is the bottom shift shaft. The shift shaft does not move. An interlock pin, in the intermediate case, holds the shaft in place. Instead, the shift shaft has detents for the detent ball and spring located in the reverse shift lever (274). When moving the 5th shift shaft (251) forward, the retaining clip at the rear of the reverse shift lever (274) moves the reverse shift lever (274). The reverse shift fork (270) swivels on the reverse shift lever (274). The reverse shift fork (270) pivots on the reverse shift fork bracket (272) in order to increase the movement of the reverse shift fork (270). To help prevent a mis-shift to the reverse position, a reverse restrictor (91) is located in the extension housing. When going into reverse, a finger on the shift control shaft (281) contacts the plunger on the reverse restrictor (91). Compressing the spring gives the driver a restricted feel when shifting to reverse. Detent balls and springs hold the 1st/2nd shift shaft (211) and the 5th shift shaft (251) in the shift positions. On the right side of the intermediate case are the detent plugs for accessing the detent balls and springs. Even though there is a detent plug for the reverse shift shaft (271), no detent spring and ball is located there. To aid in easy shift operation, the front case shift shaft bushings (295) and the intermediate case shift shaft bushings (296) support the 1st/2nd shift shaft (211), the 3rd/4th shift shaft (231) and the 5th shift shaft (251). Supporting the shift control shaft (281) at each end are the extension housing shift shaft bushings (297).

Power Flow - Forward Gears

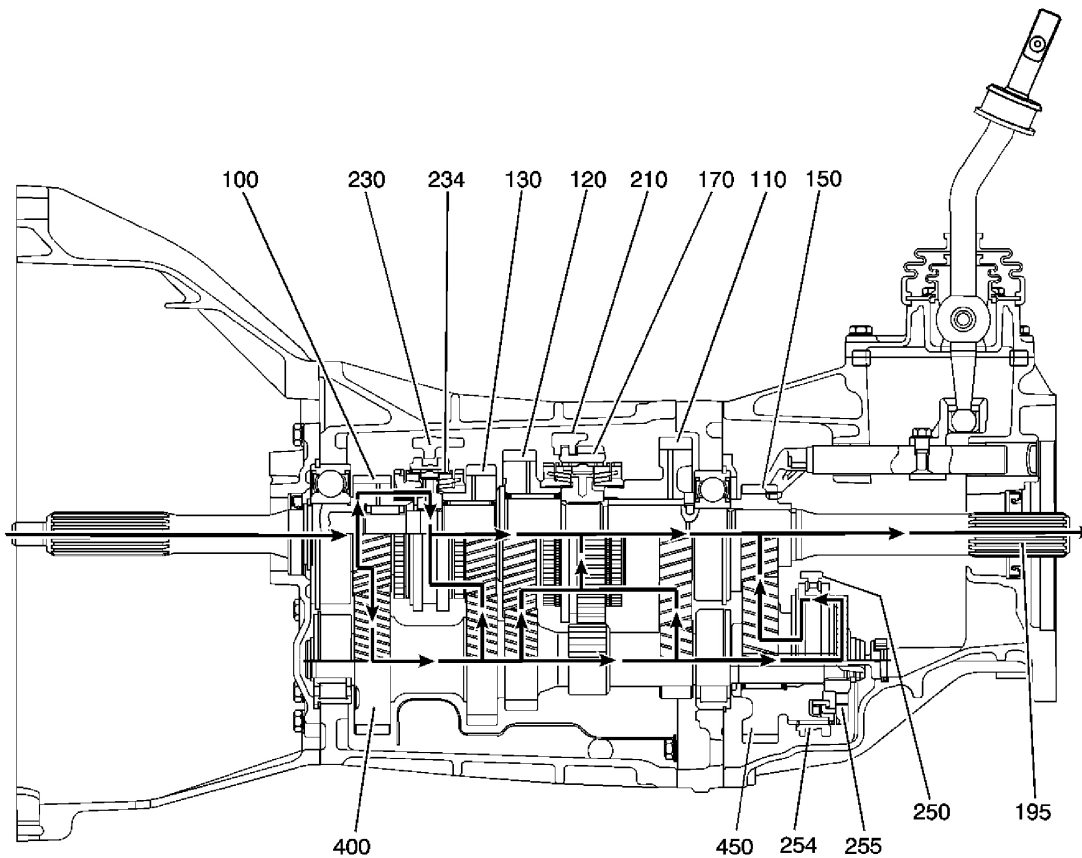

Fig. 284: Power Flow - Forward Gears
Courtesy of GENERAL MOTORS CORP.

The power flow through the AR5 transmission speed gears is a basic transmission design. During 1st gear (110), 2nd gear (120) or 3rd gear (130), the input shaft (100) delivers the power from the engine to the transmission. The external teeth on the input shaft (100) engage with the front gear on the counter shaft (400). Depending on the selected gear position, the power flows from a countershaft gear to a speed gear and then through the speed gear selector teeth. The gear selector teeth engage with the synchronizer sleeve. The synchronizer sleeve is slip splined on the synchronizer hub. The synchronizer hubs are press fit on the output shaft, therefore delivering the engine power to the output shaft (195).

1st gear

Moving the 1st/2nd shift fork (210) rearward, moves the 1st/2nd synchronizer sleeve (170). The inner teeth on the synchronizer sleeve push against the blocking ring teeth, causing the synchronizer rings to contact and the speed gear and the output shaft to match speeds. The synchronizer sleeve (170) then engages the selector teeth on 1st gear (110). Power flow is

now from the input shaft (100) to the countershaft (400) to the 1st gear (110), through the synchronizer and to the output shaft (195).

2nd gear

Moving the 1st/2nd shift fork (210) forward, moves the 1st/2nd synchronizer sleeve (170). The inner teeth on the synchronizer sleeve push against the blocking ring teeth, causing the synchronizer rings to contact and the speed gear and the output shaft to match speeds. The synchronizer sleeve (170) then engages the selector teeth on 2nd gear (120). Power flow is now from the input shaft (100) to the countershaft (400) to the 2nd gear (120) through the synchronizer and to the output shaft (195).

3rd gear

Moving the 3rd/4th shift fork (230) rearward, moves the 3rd/4th synchronizer sleeve (234). The inner teeth on the synchronizer sleeve push against the blocking ring teeth, causing the synchronizer rings to contact and the speed gear and the output shaft to match speeds. The synchronizer sleeve (234) then engages the selector teeth on 3rd gear (130). Power flow is now from the input gear (100) to the countershaft (400) to the 3rd gear (130) through the synchronizer and to the output shaft (195).

4th gear

In 4th gear, the power flow goes directly from the input shaft (100) to the output shaft (195) through the 3rd/4th synchronizer. This happens because 4th gear is the same ratio as the engine speed. When moving the 3rd/4th shift fork (230), the 3rd/4th synchronizer sleeve (234) inner teeth push against the single blocking ring teeth for 4th gear. Matching the input shaft (100) to the output shaft (195) allows the synchronizer sleeve to engage to the selector teeth on the input shaft (100).

5th gear

5th gear is an overdrive ratio. Because 5th gear is overdrive, the 5th gear (150) is splined on the rear of the output shaft (195). The 5th countershaft gear (450) is located on the rear of the countershaft (400) and rotates on needle bearings. The 5th countershaft gear (450) is larger diameter, with more teeth than 5th gear (150). The power flow for 5th gear is from the input shaft (100) to the countershaft (400). Moving the 5th shift fork (250) rearward, the 5th/reverse synchronizer sleeve (254) pushes against the teeth on the blocking ring, forcing the blocking ring against the middle ring. The middle ring has tabs in the 5th synchronizer gear (255). The blocking rings match the speed of the 5th synchronizer gear (255) and the 5th countershaft gear (250), which is rotating by the 5th gear (150). Matching the speeds,

the synchronizer sleeve slides onto the 5th synchronizer gear. Power flows from the countershaft (400) to the 5th synchronizer gear (255), through the synchronizer sleeve. With the synchronizer sleeve also engaged with the 5th countershaft gear (450), power flows from the 5th countershaft gear (450) to the 5th gear (150) and to the output shaft (195), which now turns faster than the speed of the input shaft (100).

Power Flow - Reverse Gear

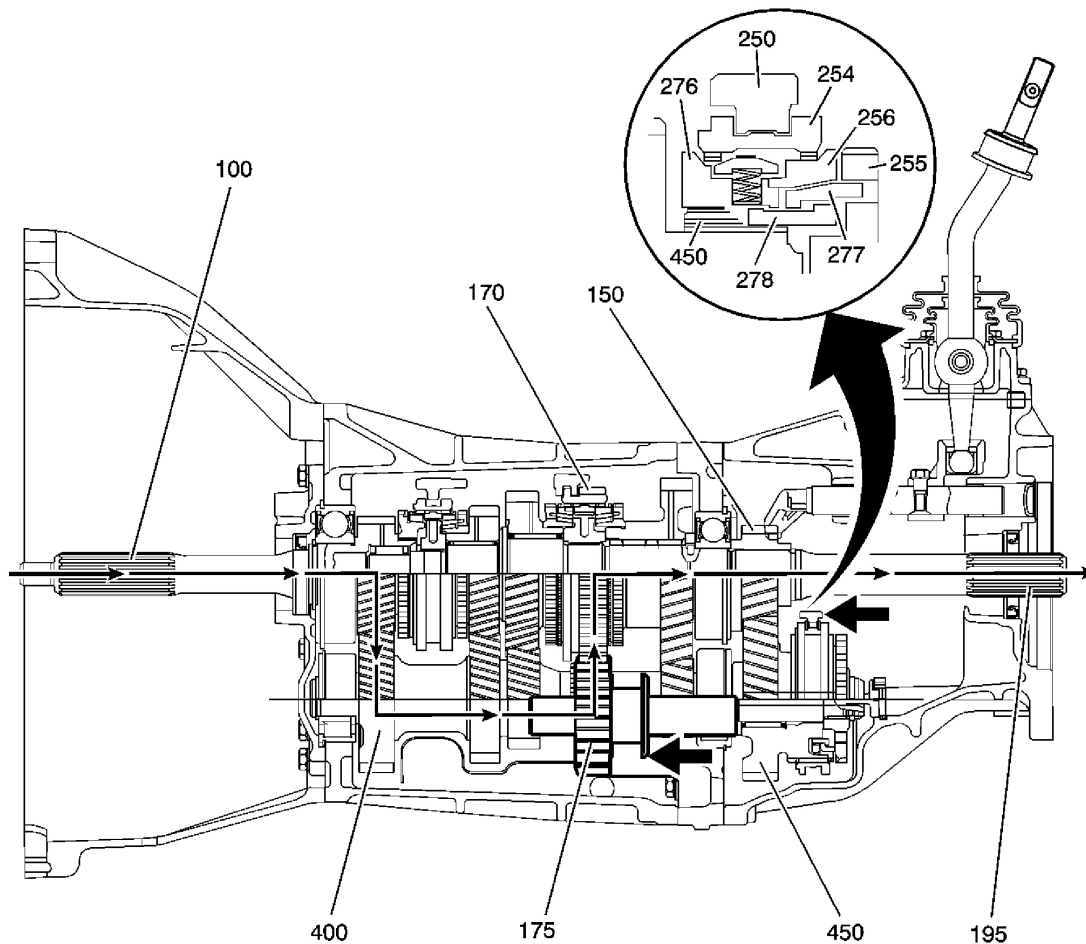

Fig. 285: Power Flow - Reverse Gear
Courtesy of GENERAL MOTORS CORP.

Moving the reverse shift fork forward, slides the reverse idler gear (175) forward on the reverse idler gear shaft. The reverse idler gear (175) engages with the countershaft reverse gear and with the outer or reverse gear teeth on the 1st/2nd synchronizer sleeve (170). The synchronizer sleeve is the reverse gear in this application. The synchronizer sleeve (170) is slip splined on the synchronizer hub. The synchronizer hub is pressed on the output shaft (195). The power flow in

reverse is from the input shaft (100), to the countershaft (400), to the reverse idler gear (175), to the reverse gear teeth on the 1st/2nd synchronizer sleeve (170), through the synchronizer and to the output shaft (195). Using the 5th/reverse synchronizer avoids gear clash when shifting in reverse. When moving the reverse shift fork forward, simultaneously the 5th shift fork (250) moves the 5th/reverse synchronizer sleeve (254) forward. The internal splines of the synchronizer sleeve slide on the splines of the 5th countershaft gear (450). At the same time, the synchronizer sleeve splines are pushing against the teeth on the reverse gear synchronizer ring (276). The action moves the reverse gear synchronizer ring (276) forward. The reverse/5th inner ring (278) or pull ring, locking to the reverse gear synchronizer ring (276) moves forward. The reverse/5th inner ring (278) pulls forward and tabbed lock to the reverse/5th internal ring (277) forces the reverse internal ring (277) against the 5th gear blocking ring (256). The 5th gear blocking ring (256) is moving at the same revolutions as the output shaft (195). The reverse internal ring (277), tabbed to the 5th synchronizer gear (255), is revolving at the countershaft (400) speed. The synchronizer action matches the revolutions of the countershaft (400) to output shaft (195) revolutions, allowing the reverse idler (175) to engage without gear clashing.

SPECIAL TOOLS AND EQUIPMENT

SPECIAL TOOLS

Special Tools

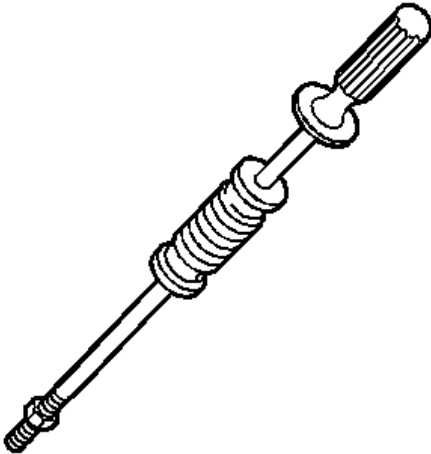
Illustration	Tool Number/Description
	<p style="text-align: center;">J 6125-1B Slide Hammer with Adapter</p>

2007 Hummer H3

2007 TRANSMISSION Manual Transmission - Aisin AR5 - H3

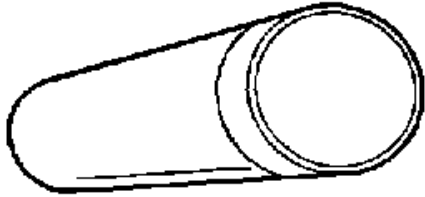

J 6133-A
Bearing Race Installer

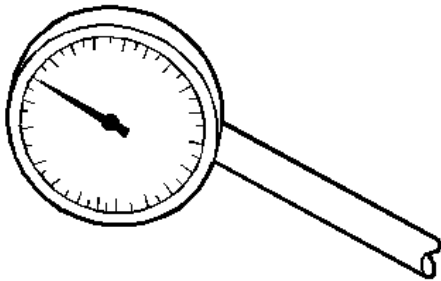

J 8001-3
Dial Indicator

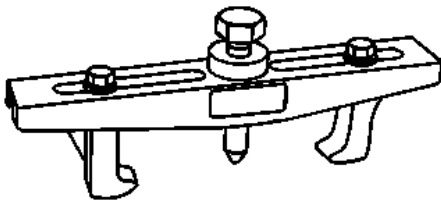

J 8433
Two Jaw Puller

J 22912-01
Rear Pinion and Axle Bearing
Remover

2007 Hummer H3

2007 TRANSMISSION Manual Transmission - Aisin AR5 - H3

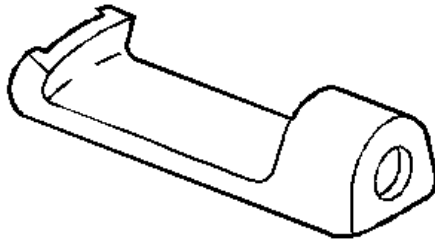
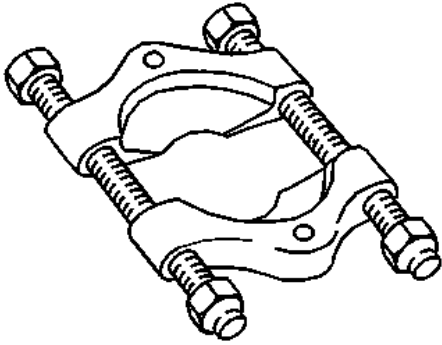

J 23129
Universal Seal Remover

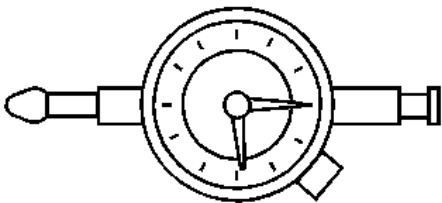

J 26900-12
Dial Indicator

J 26900-13

2007 Hummer H3

2007 TRANSMISSION Manual Transmission - Aisin AR5 - H3

Magnetic Indicator Base

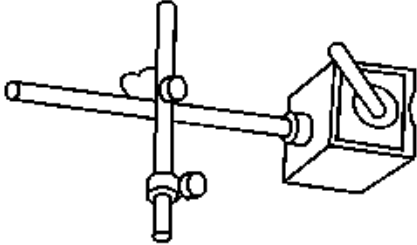

J 35616
GM-Approved Terminal Test Kit



J 36850
Transjel Lubricant

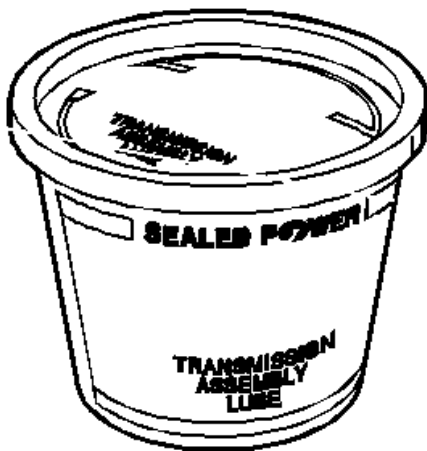

2007 Hummer H3

2007 TRANSMISSION Manual Transmission - Aisin AR5 - H3

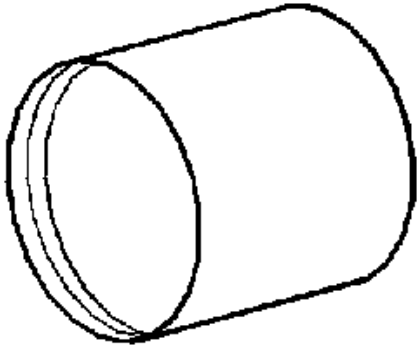

J 39924-2
5th Gear Drag Seal Installer

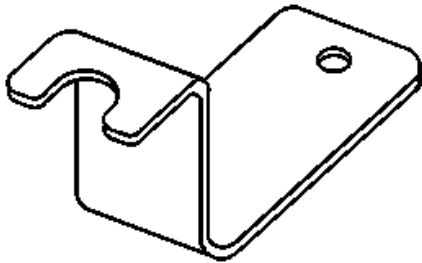

J 42371
Hydraulic Clutch Line Separator

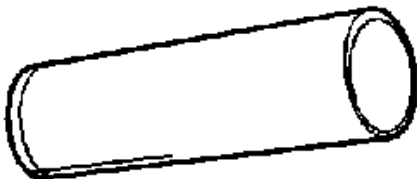

J 44339
Reverse Synchronizer Installer

2007 Hummer H3

2007 TRANSMISSION Manual Transmission - Aisin AR5 - H3

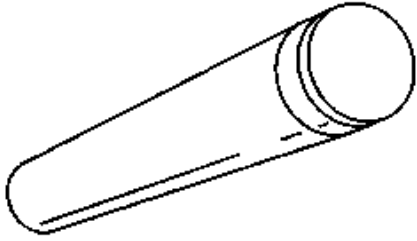

J 44340
Bearing Installer

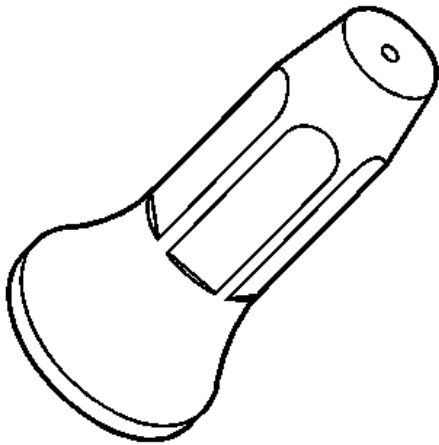

J 45866
Input Shaft Seal Installer

J 45867
4WD Output Shaft Seal Installer

2007 Hummer H3

2007 TRANSMISSION Manual Transmission - Aisin AR5 - H3

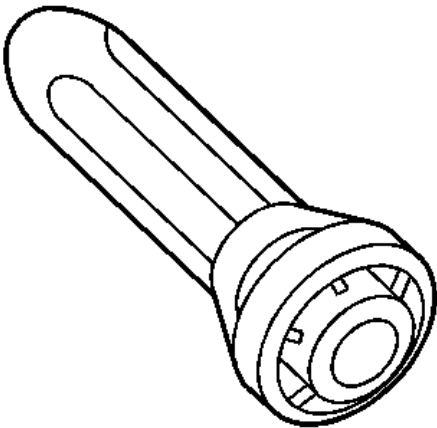
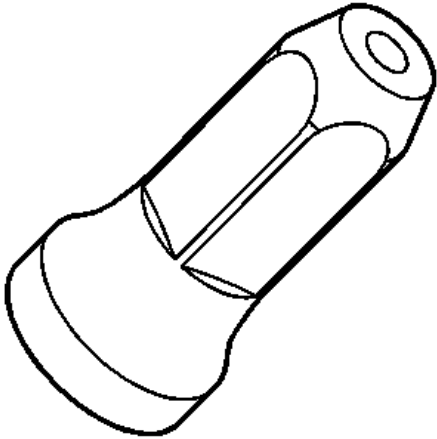

J 45868
RWD Output Shaft Seal Installer

J 45869
Gear Protector Plates

2007 Hummer H3

2007 TRANSMISSION Manual Transmission - Aisin AR5 - H3

