

2007 Hummer H3

2007 ACCESSORIES & EQUIPMENT Frame and Underbody - H3

2007 ACCESSORIES & EQUIPMENT

Frame and Underbody - H3

SPECIFICATIONS

FASTENER TIGHTENING SPECIFICATIONS

Fastener Tightening Specifications

Application	Specification	
	Metric	English
Assist Step Bolt	50 N.m	37 lb ft
Crossmember Bolt		
• First Pass	70 N.m	52 lb ft
• Second Pass	Plus 200 Degrees	
Engine Shield Bolt	20 N.m	15 lb ft
Frame Cushion/Insulator Bolt	115 N.m	85 lb ft
Front Differential Assembly Bolt	100 N.m	74 lb ft
Oil Pan Skid Plate Bolt	20 N.m	15 lb ft
Tow Hook Bracket to Front Frame Rail Bolt	85 N.m	63 lb ft
Tow Hook Bracket to Rear Frame Rail Bolt	100 N.m	74 lb ft
Tow Hook D-Ring Nut		
• First Pass	50 N.m	37 lb ft
• Second Pass	Minus Approximately 180 Degrees	
Trailer Hitch to Frame (Horizontal) Bolt	160 N.m	118 lb ft
Trailer Hitch to Frame (Vertical) Bolt	100 N.m	74 lb ft
Transmission Crossmember to Frame (Vertical) Bolt	100 N.m	74 lb ft
Transmission Crossmember to Frame Bracket (Horizontal) Nut	50 N.m	37 lb ft
Transmission Mount to Support Nut	57 N.m	42 lb ft
Wheelhouse Panel Bolts	10 N.m	89 lb in

REPAIR INSTRUCTIONS

REAR TOW EYE REPLACEMENT

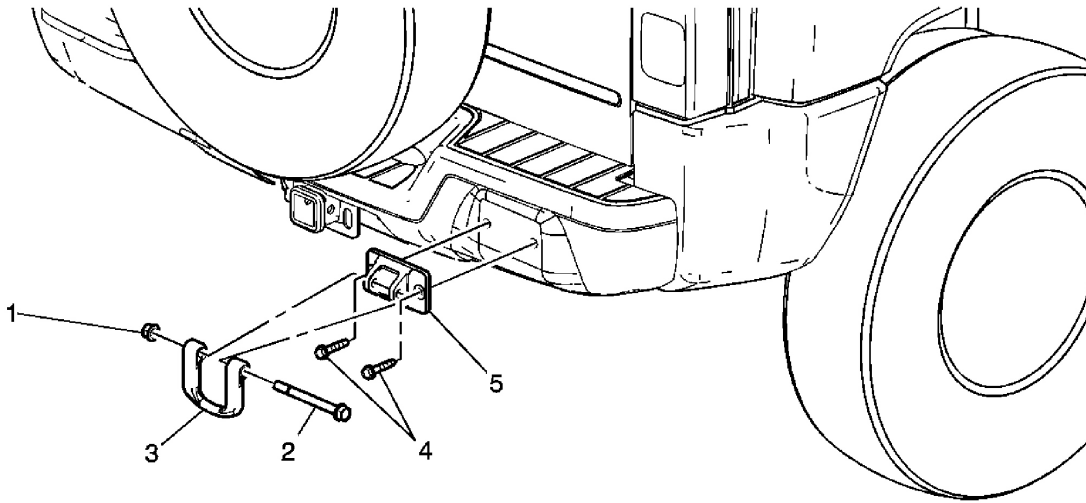

Fig. 1: Rear Tow Eye/D-Ring Replacement
 Courtesy of GENERAL MOTORS CORP.

Rear Tow Eye Replacement

Callout	Component Name
1	Tow Hook Nut NOTE: Refer to <u>Fastener Notice</u> . Tip: The nut should be tight enough to keep the hook from rattling against the bumper and loose enough to be moveable by hand. Tighten: 50 N.m (37 lb ft) minus approximately 180 degrees
2	Tow Hook Bolt
3	Tow Hook
4	Tow Hook Bracket Bolt (Qty: 2) Tip: It may be necessary to remove the impact bar assembly to access additional bolts for the tow hook bracket. Refer to <u>Rear Bumper Impact Bar Replacement</u> . Tighten: 100 N.m (74 lb ft)
5	Tow Hook Bracket

FRONT TOW HOOK REPLACEMENT

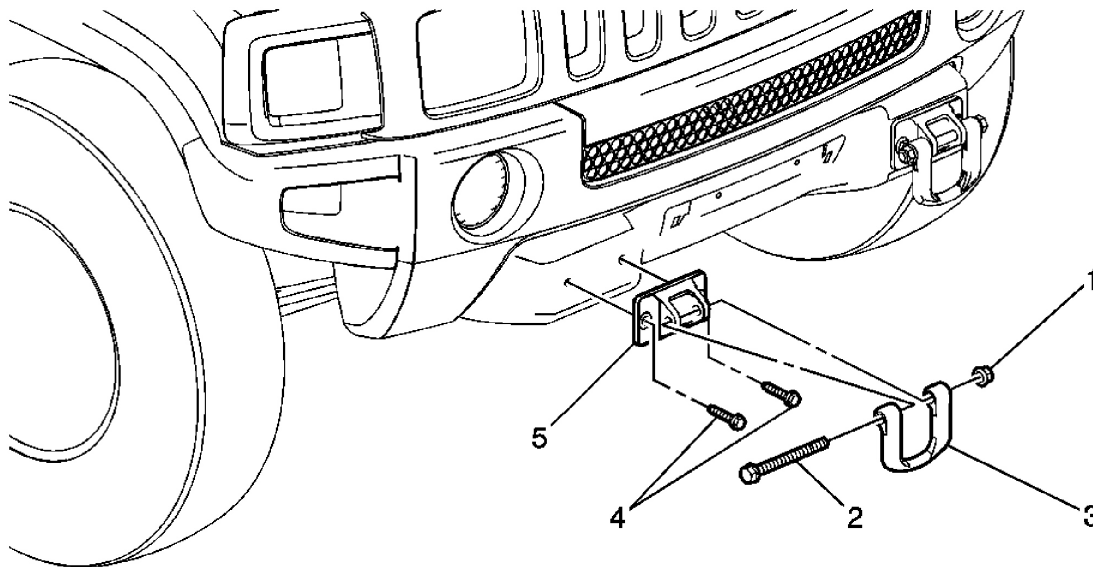

Fig. 2: Tow Hook Replacement - Front
 Courtesy of GENERAL MOTORS CORP.

Front Tow Hook Replacement

Callout	Component Name
1	Tow Hook Nut NOTE: Refer to <u>Fastener Notice</u> . Tip: The nut should be tight enough to keep the hook from rattling against the bumper and loose enough to be moveable by hand. Tighten: 50 N.m (37 lb ft) minus approximately 180 degrees
2	Tow Hook Bolt
3	Tow Hook
4	Tow Hook Bracket Bolts (Qty: 2) Tip: It may be necessary to remove the bumper assembly to access additional bolts for the tow hook bracket. Refer to <u>Front Bumper Fascia Replacement</u> . Tighten: 85 N.m (63 lb ft)
5	Tow Hook Bracket

OIL PAN SKID PLATE REPLACEMENT

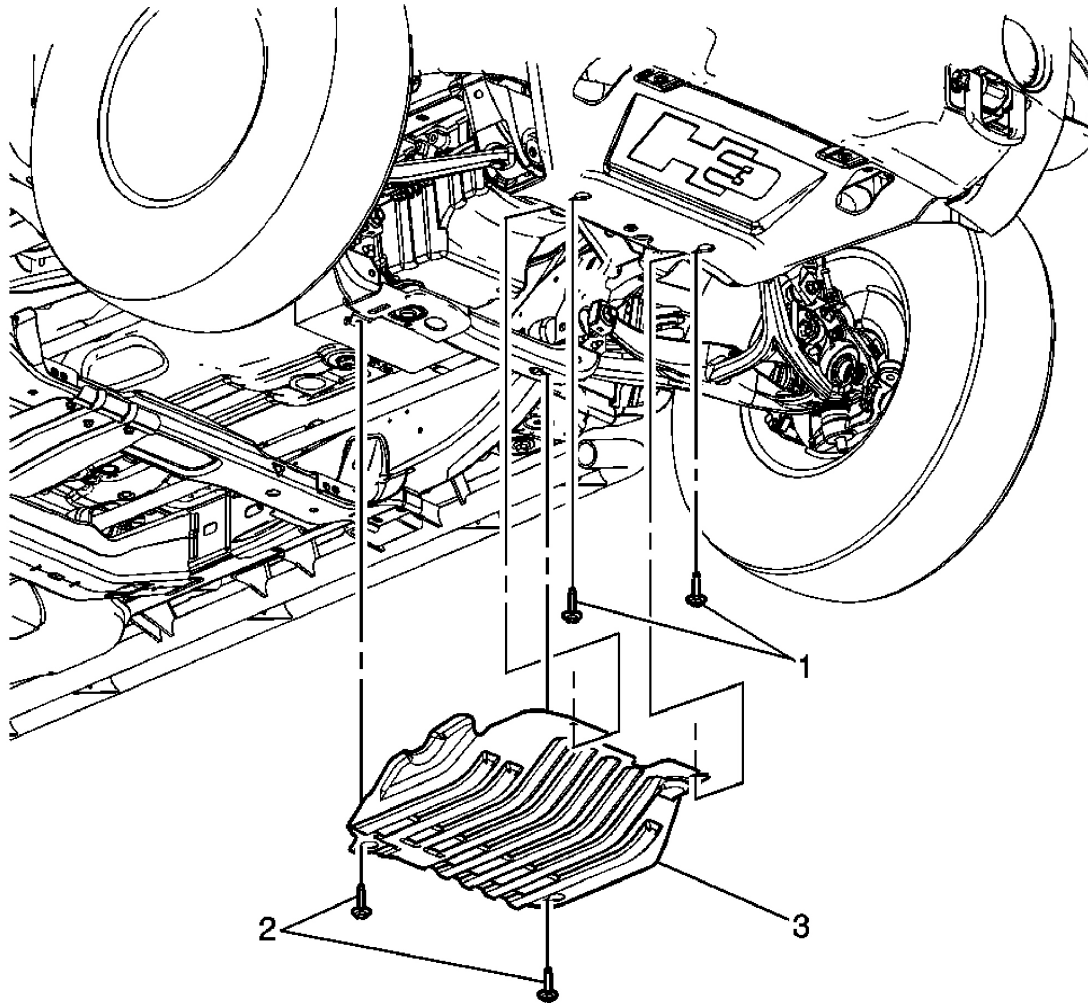

Fig. 3: Replacing Oil Pan Skid Plate
 Courtesy of GENERAL MOTORS CORP.

Oil Pan Skid Plate Replacement

Callout	Component Name
<p>NOTE: Refer to <u>Fastener Notice</u> .</p> <p>Fastener Tightening Specifications: Refer to <u>Fastener Tightening Specifications</u>. Preliminary Procedure: Raise the vehicle. Refer to <u>Lifting and Jacking the Vehicle</u> .</p>	
	<p>Bolts, Oil Pan Skid Plate (Qty: 2)</p>

2007 Hummer H3

2007 ACCESSORIES & EQUIPMENT Frame and Underbody - H3

1	Tighten: 20 N.m (15 lb ft)
2	Bolts, Oil Pan Skid Plate (Qty: 2) Tighten: 20 N.m (15 lb ft)
3	Plate, Oil Pan Skid

ENGINE SHIELD REPLACEMENT

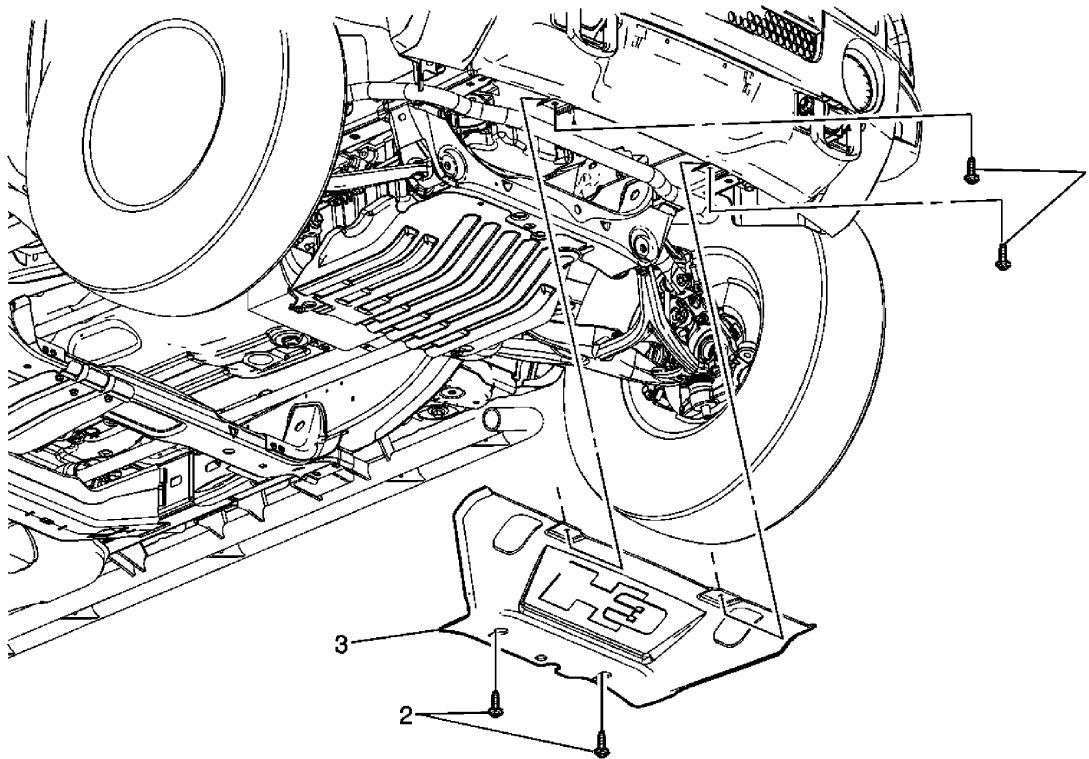

Fig. 4: Replacing Engine Shield
 Courtesy of GENERAL MOTORS CORP.

Engine Shield Replacement

Callout	Component Name
<p>NOTE: Refer to <u>Fastener Notice</u> .</p> <p>Fastener Tightening Specifications: Refer to <u>Fastener Tightening Specifications</u>. Preliminary Procedure: Raise the vehicle. Refer to <u>Lifting and Jacking the Vehicle</u> .</p>	

2007 Hummer H3

2007 ACCESSORIES & EQUIPMENT Frame and Underbody - H3

1	Bolts, Engine Shield (Qty: 2) Tighten: 20 N.m (15 lb ft)
2	Bolts, Engine Shield (Qty: 2) Tighten: 20 N.m (15 lb ft)
3	Shield, Engine

REAR BUMPER IMPACT BAR EXTENSION REPLACEMENT

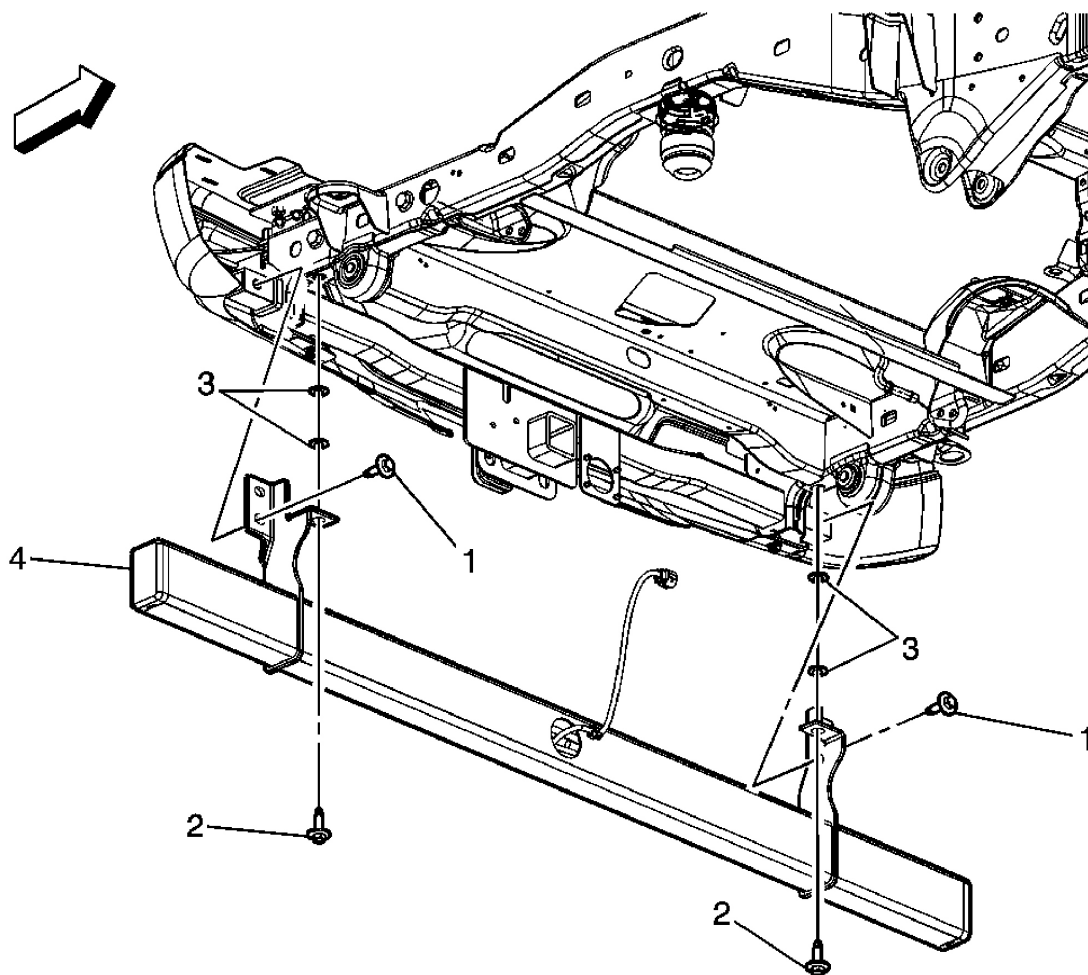

Fig. 5: View Of Rear Bumper Impact Bar Extension
 Courtesy of GENERAL MOTORS CORP.

Rear Bumper Impact Bar Extension Replacement

Callout	Component Name
---------	----------------

2007 Hummer H3

2007 ACCESSORIES & EQUIPMENT Frame and Underbody - H3

Preliminary Procedure

1. Raise the vehicle. Refer to **Lifting and Jacking the Vehicle** .
2. Disconnect the electrical connector.

1	Rear Bumper Impact Bar Extension Bolt (Qty: 2) NOTE: Refer to <u>Fastener Notice</u> . Tighten: 35 N.m (26 lb in)
2	Rear Bumper Impact Bar Extension Bolt (Qty: 2) Tighten: 35 N.m (26 lb in)
3	Rear Bumper Impact Bar Extension Washer (Qty: 4)
4	Rear Bumper Impact Bar Extension

CROSSMEMBER REPLACEMENT

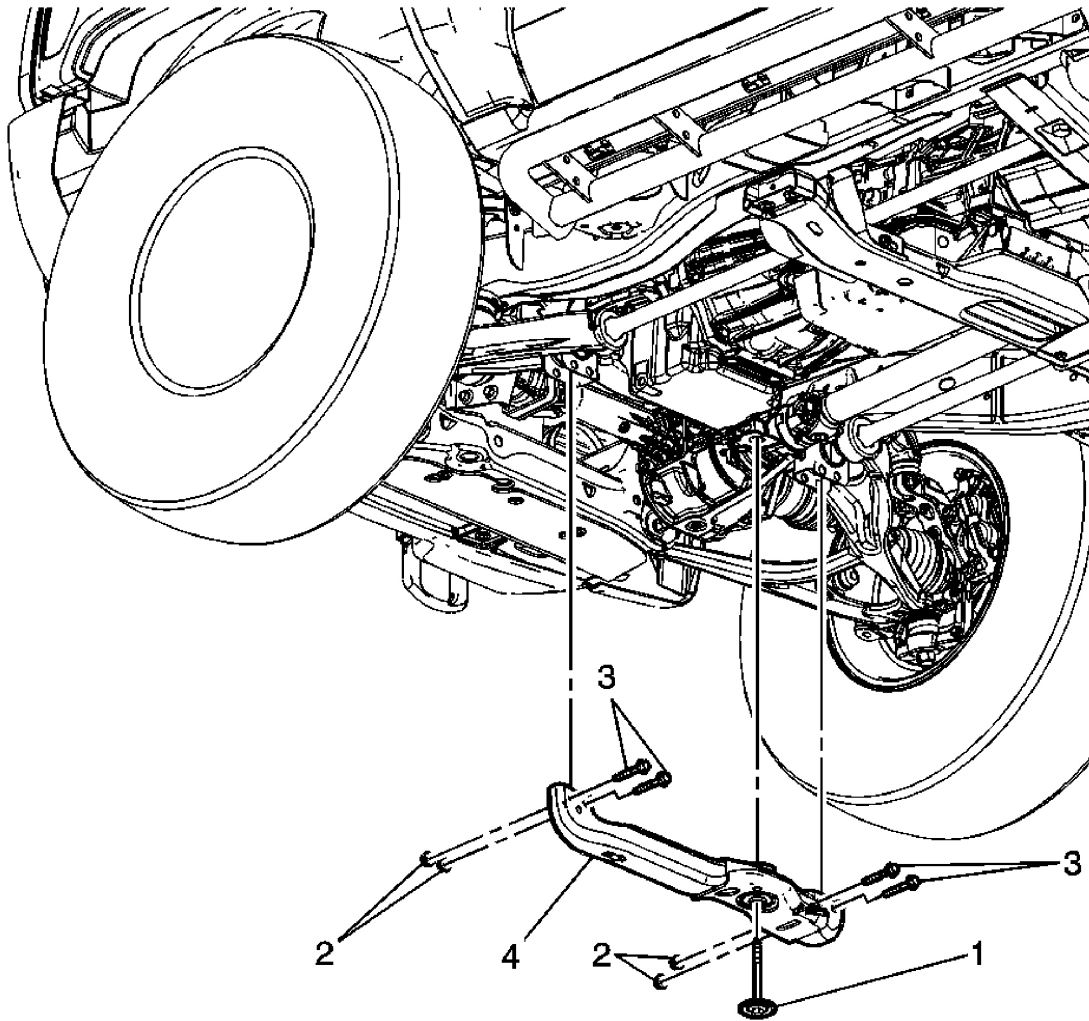

Fig. 6: Replacing Crossmember
 Courtesy of GENERAL MOTORS CORP.

Crossmember Replacement

Callout	Component Name
Preliminary Procedures	
<ol style="list-style-type: none"> 1. Raise the vehicle. Refer to <u>Lifting and Jacking the Vehicle</u> . 2. Remove the engine shield. Refer to <u>Engine Shield Replacement</u>. 3. Remove the oil pan skid plate. Refer to <u>Oil Pan Skid Plate Replacement</u>. 4. Support the front differential assembly. 	
	Front Differential Assembly Bolt

2007 Hummer H3

2007 ACCESSORIES & EQUIPMENT Frame and Underbody - H3

1	NOTE: Refer to <u>Fastener Notice</u> . Tighten: 100 N.m (74 lb ft)
2	Crossmember Nut (Qty: 4) Tighten: 70 N.m (52 lb ft) plus 200 degrees
3	Crossmember Bolt (Qty: 4)
4	Crossmember

TRANSMISSION SUPPORT CROSSMEMBER REPLACEMENT

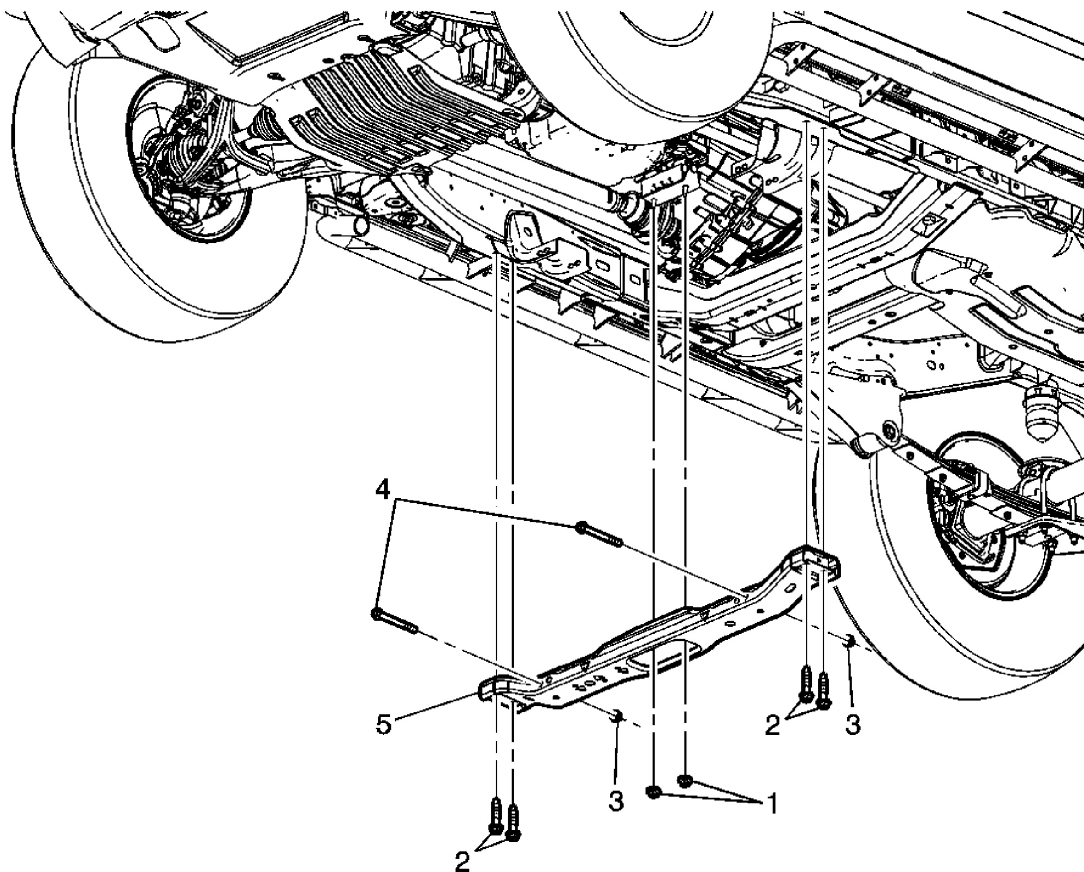

Fig. 7: View Of Transmission Support Crossmember
Courtesy of GENERAL MOTORS CORP.

Transmission Support Crossmember Replacement

Callout	Component Name
---------	----------------

2007 Hummer H3

2007 ACCESSORIES & EQUIPMENT Frame and Underbody - H3

NOTE:

Refer to Fastener Notice .

Fastener Tightening Specifications: Refer to Fastener Tightening Specifications .

Preliminary Procedures

1. Raise the vehicle. Refer to Lifting and Jacking the Vehicle .
2. Remove the transfer case shield. Refer to Transfer Case Shield Replacement .
3. Support the transmission with a transmission jack.

1	Transmission Mount Nut (Qty: 2) Tighten: 57 N.m (42 lb ft)
2	Transmission Support Bolt (Qty: 4) Tighten: 100 N.m (74 lb ft)
3	Transmission Support Nut (Qty: 4) Tighten: 50 N.m (37 lb ft)
4	Transmission Support Bolt (Qty: 4)
5	Transmission Support

FRAME CUSHION OR INSULATOR REPLACEMENT

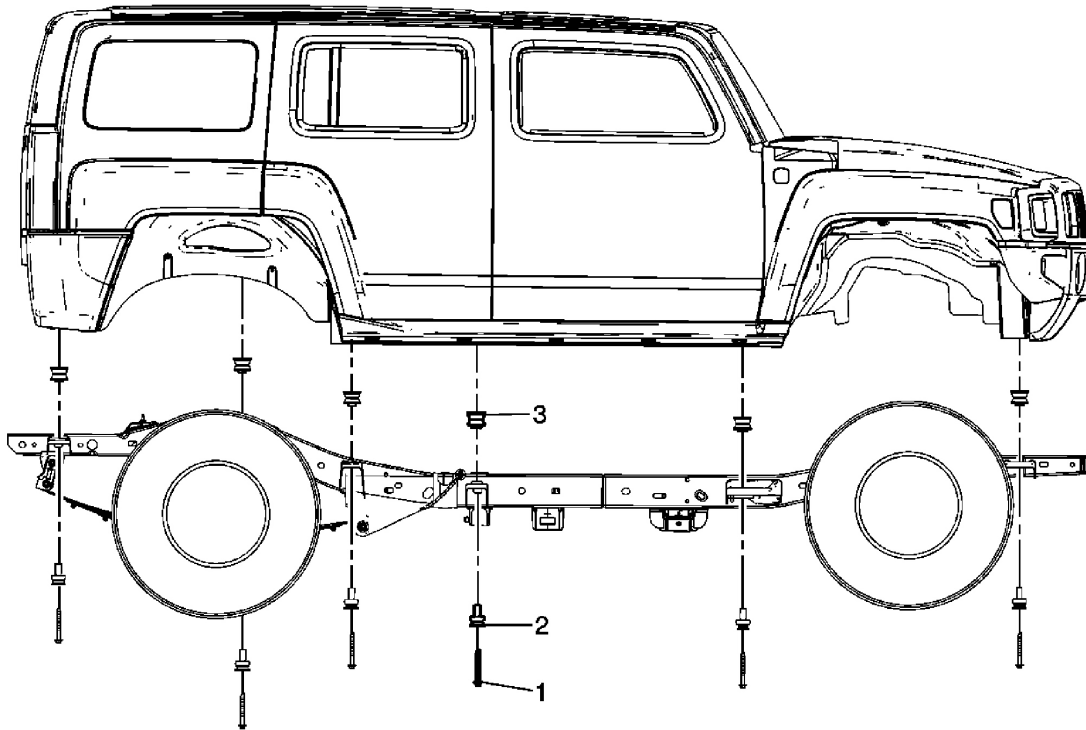

Fig. 8: Locating Frame Cushion Or Insulators
 Courtesy of GENERAL MOTORS CORP.

Frame Cushion or Insulator Replacement

Callout	Component Name
<p>NOTE: Refer to <u>Fastener Notice</u> .</p> <p>Fastener Tightening Specifications: Refer to <u>Fastener Tightening Specifications</u>. Preliminary Procedure: Raise the vehicle. Refer to <u>Lifting and Jacking the Vehicle</u> .</p>	
1	<p>Bolt, Frame cushion/Insulator (Qty: 12) Tip: It is only necessary to remove the cushion/insulator bolt of the cushion/insulator being replaced. Though it may be necessary to loosen the cushion/insulator bolts to either side of the cushion/insulator being replaced in order to gain enough clearance to remove the cushion/insulator(s) being replaced. Tighten: 115 N.m (85 lb ft)</p>
2	<p>Cushion/Insulator, Frame (Qty: 12)</p>

3 Cushion/Insulator, Frame (Qty: 12)

WHEELHOUSE PANEL REPLACEMENT (FRONT)

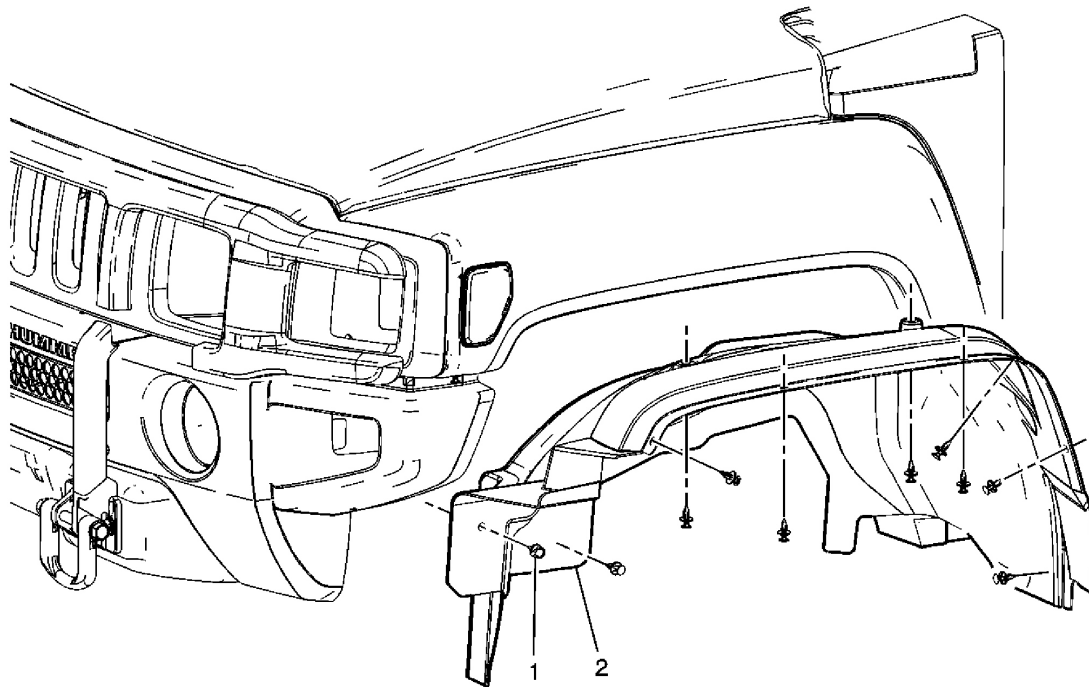

Fig. 9: Replacing Wheelhouse Panel
 Courtesy of GENERAL MOTORS CORP.

Wheelhouse Panel Replacement (Front)

Callout	Component Name
Fastener Tightening Specifications: Refer to <u>Fastener Tightening Specifications</u> .	
Preliminary Procedures	
1. Lift and support vehicle. Refer to <u>Lifting and Jacking the Vehicle</u> .	
2. Remove the front wheel. Refer to <u>Tire and Wheel Removal and Installation</u> .	
1	Retainer, Front Wheelhouse Panel (Qty: 10)
2	Panel, Front Wheelhouse

WHEELHOUSE PANEL REPLACEMENT (REAR)

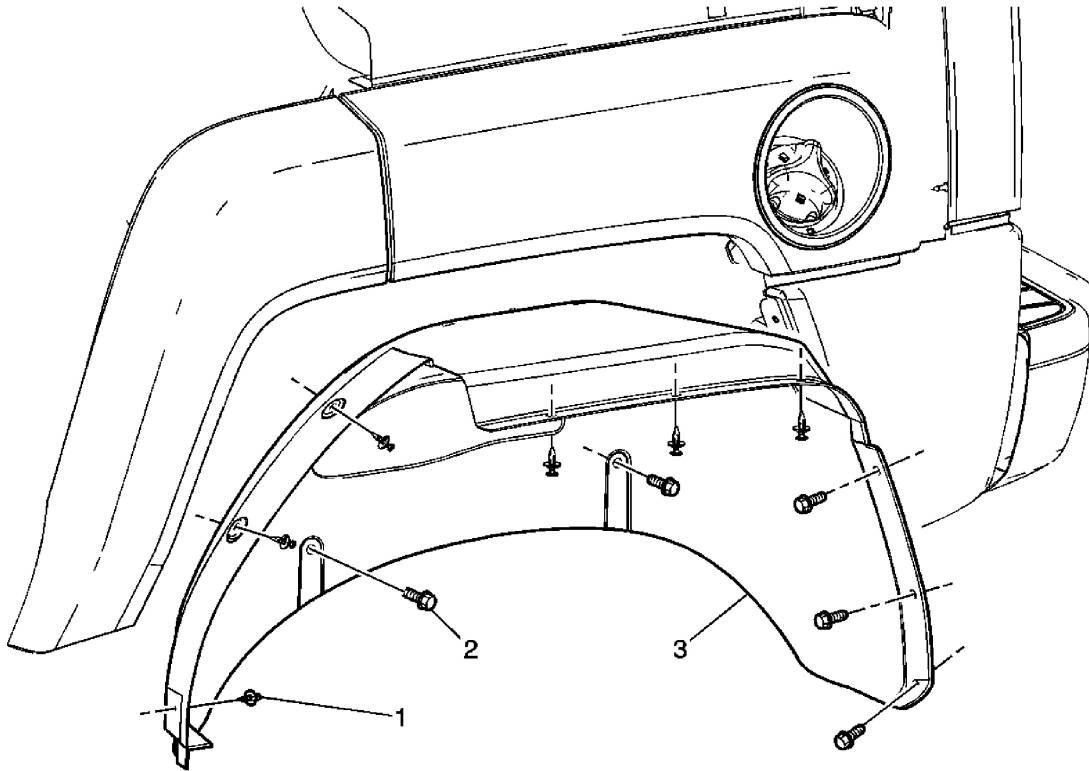

Fig. 10: View Of Rear Wheelhouse Panel
 Courtesy of GENERAL MOTORS CORP.

Wheelhouse Panel Replacement (Rear)

Callout	Component Name
Fastener Tightening Specifications: Fastener Tightening Specifications.	
1	Retainer, Wheelhouse (Qty: 6)
2	Bolts, Wheelhouse Panel (Qty: 5) Tighten: 10 N.m (89 lb in)
3	Panel, Wheelhouse Rear

ASSIST STEP REPLACEMENT (ASSIST STEP)

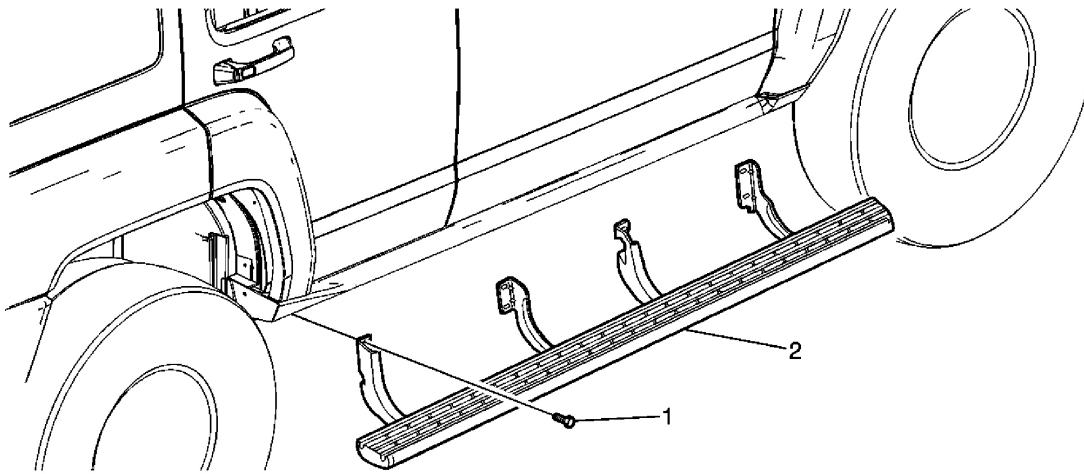

Fig. 11: Replacing Assist Step
 Courtesy of GENERAL MOTORS CORP.

Assist Step Replacement (Assist Step)

Callout	Component Name
<p>NOTE: Refer to <u>Fastener Notice</u> .</p> <p>Fastener Tightening Specifications: Refer to <u>Fastener Tightening Specifications</u>. Preliminary Procedure: Raise the vehicle. Refer to <u>Lifting and Jacking the Vehicle</u> .</p>	
<p>1</p>	<p>Assist Step Bolts (Qty: 8)</p> <p>Tighten: 50 N.m (37 lb in)</p>
<p>2</p>	<p>Assist Step</p>

ASSIST STEP REPLACEMENT (SIDE STEP)

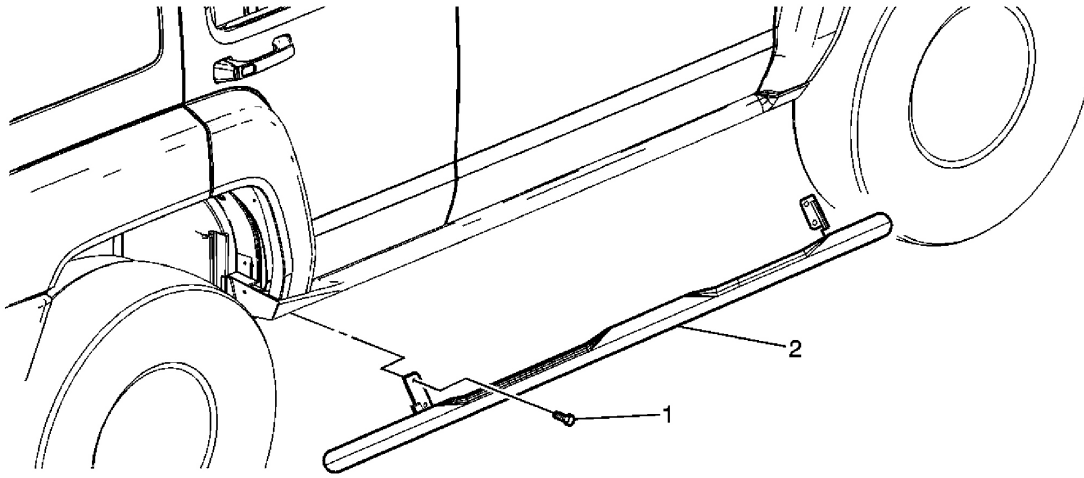

Fig. 12: Replacing Side Assist Step
 Courtesy of GENERAL MOTORS CORP.

Assist Step Replacement (Side Step)

Callout	Component Name
NOTE:	
Refer to <u>Fastener Notice</u> .	
Fastener Tightening Specifications: Refer to <u>Fastener Tightening Specifications</u> .	
Preliminary Procedure: Raise the vehicle. Refer to <u>Lifting and Jacking the Vehicle</u> .	
1	Side Step Bolts (Qty: 4)
Tighten: 50 N.m (37 lb in)	
2	Side Step

TRAILER HITCH REPLACEMENT

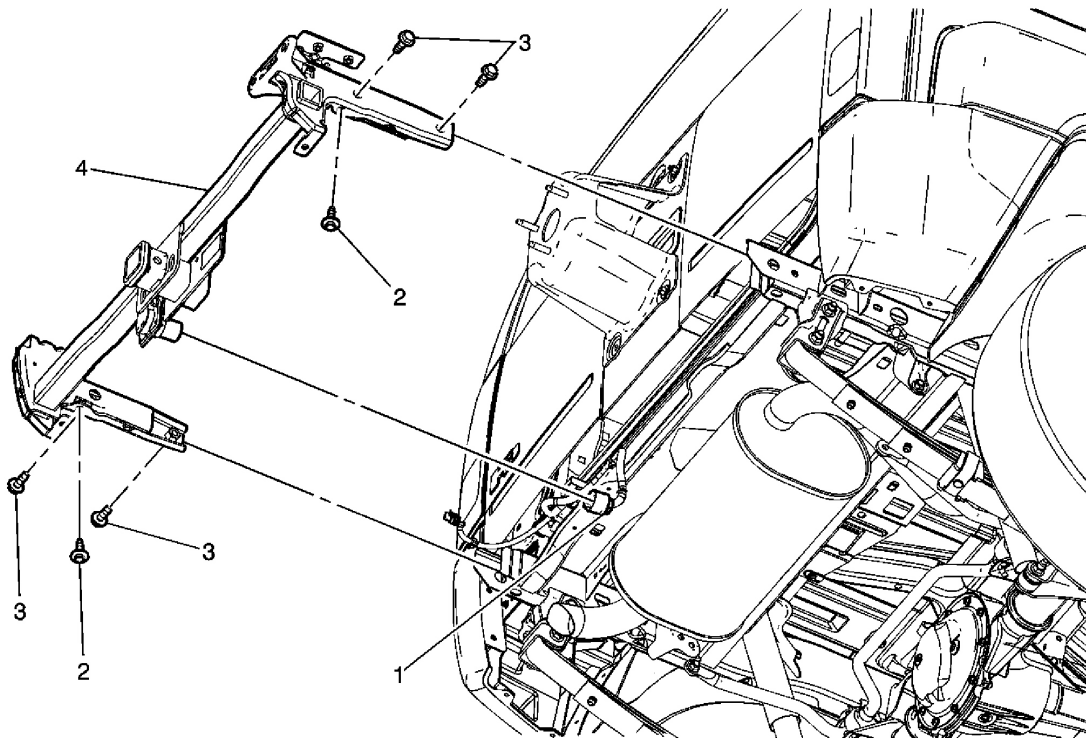

Fig. 13: Replacing Trailer Hitch
 Courtesy of GENERAL MOTORS CORP.

Trailer Hitch Replacement

Callout	Component Name
Preliminary Procedure: Remove rear bumper. Refer to Rear Bumper Impact Bar Replacement .	
1	Trailer Wire Connector
2	Trailer Hitch Bolts (Qty: 2) NOTE: Refer to Fastener Notice . Tighten: 100 N.m (74 lb ft)
3	Trailer Hitch Bolts (Qty: 4) Tighten: 160 N.m (118 lb ft)
4	Trailer Hitch