

2007 Hummer H3

2007 ACCESSORIES & EQUIPMENT Exterior Trim - H3

2007 ACCESSORIES & EQUIPMENT

Exterior Trim - H3

SPECIFICATIONS

FASTENER TIGHTENING SPECIFICATIONS

Fastener Tightening Specifications

Application	Specification	
	Metric	English
Cargo Tie Down Loops	34 N.m	25 lb ft
Front Bumper Impact Bar Bolts	50 N.m	37 lb ft
Grille Guard/Brush Guard Bolts	50 N.m	37 lb ft
Radiator Grille Nut	3 N.m	27 lb in
Rear Side Door Flare Screws	2 N.m	18 lb in
Rear Wheel Opening Flare Bolts	9 N.m	80 lb in
Rocker Panel Screws	2 N.m	18 lb in
Windshield Side Reveal Molding Screws	2 N.m	18 lb in

REPAIR INSTRUCTIONS

QUARTER PANEL UPPER APPLIQUE REPLACEMENT

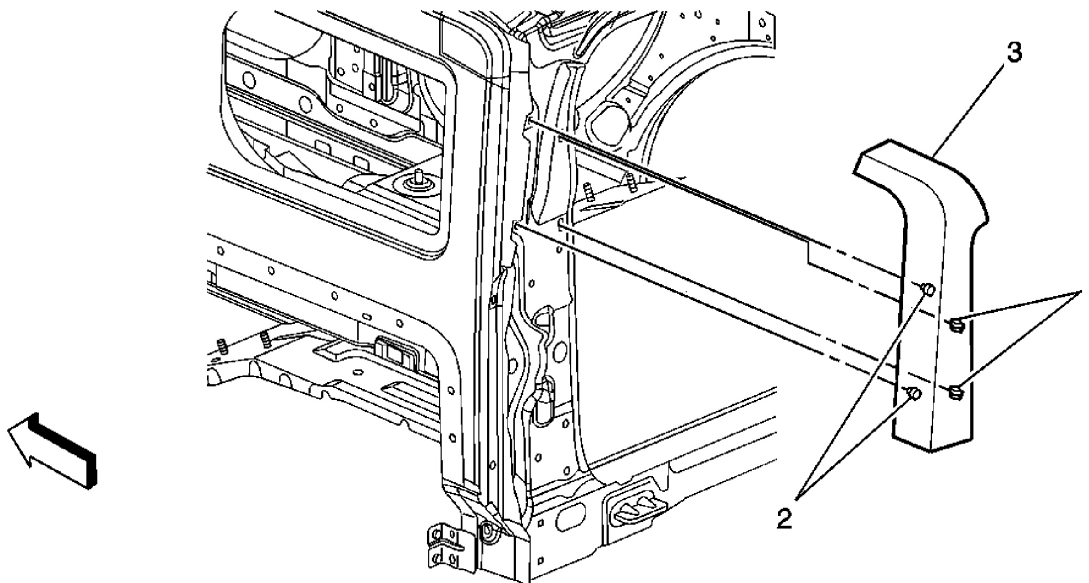

Fig. 1: Applique Replacement - Quarter Panel Upper
 Courtesy of GENERAL MOTORS CORP.

Quarter Panel Upper Applique Replacement

Callout	Component Name
Fastener Tightening Specifications: Refer to <u>Fastener Tightening Specifications</u> .	
1	Clips, Integral (Qty: 2) Tip: Pull applique inside edge outward in order to release clips.
2	Retainers, Integral (Qty: 2) Tip: Pull applique outward in order to release retainers.
3	Applique, Quarter Panel Upper

CARGO TIE DOWN LOOP BRACKET REPLACEMENT

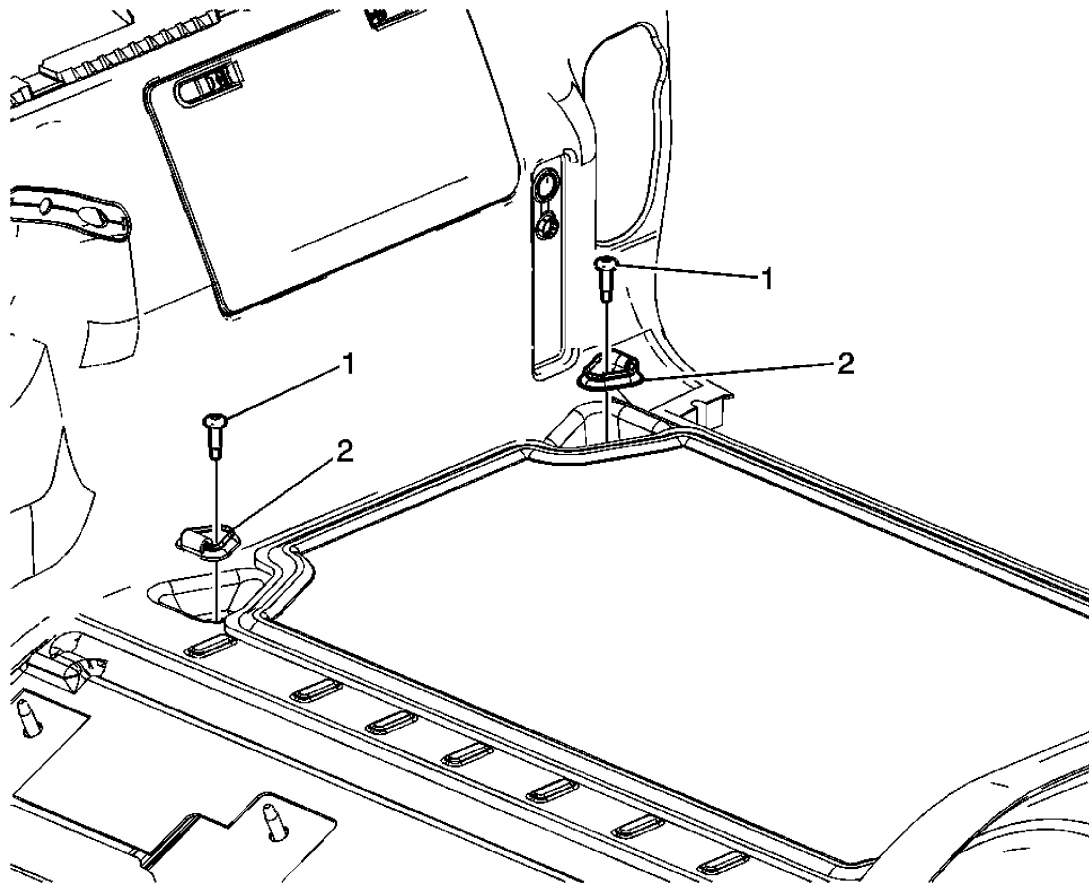

Fig. 2: Bracket Replacement - Cargo Tie Down Loop
 Courtesy of GENERAL MOTORS CORP.

Cargo Tie Down Loop Bracket Replacement

Callout	Component Name
NOTE: Refer to <u>Fastener Notice</u> .	
Fastener Tightening Specifications: Refer to <u>Fastener Tightening Specifications</u> .	
1	Bolt, Cargo Tie Down Loop (Qty: 4) Tighten: 34 N.m (25 lb ft)
2	Loop Assembly, Cargo Tie Down

DOOR EMBLEM AND NAMEPLATE REPLACEMENT (GME)

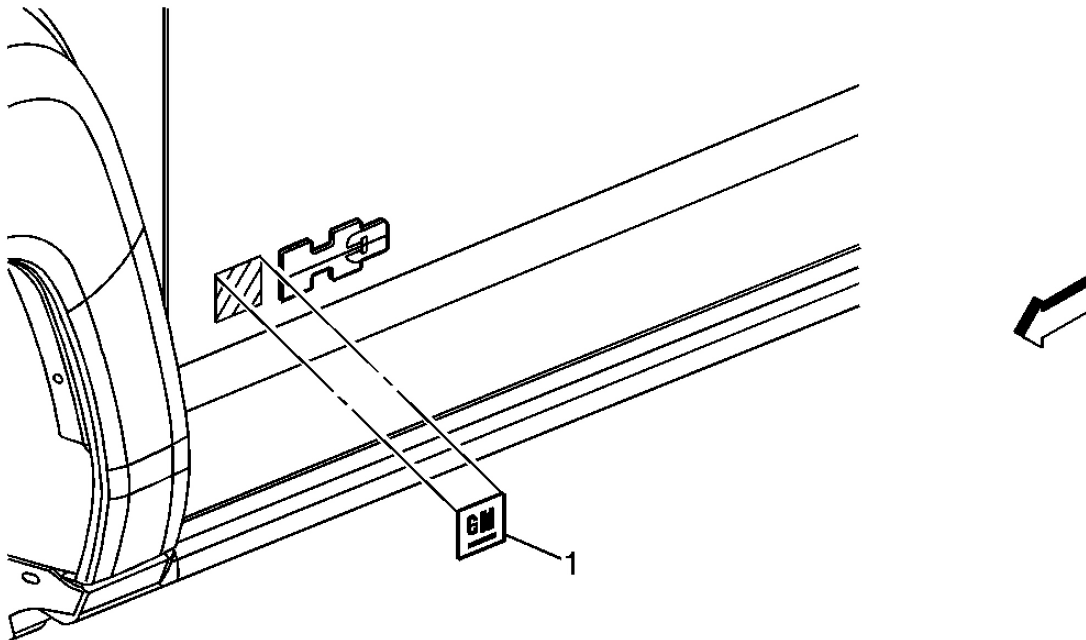

Fig. 3: View Of Door Emblem and Nameplate
 Courtesy of GENERAL MOTORS CORP.

Door Emblem and Nameplate Replacement (GME)

Callout	Component Name
Fastener Tightening Specifications: Refer to <u>Fastener Tightening Specifications</u> .	
	Front Door Nameplate 1. When removing protective liners from adhesive backed nameplates, be

1

careful not to touch the tape with hands and do not allow the tape to come in contact with dirt or any foreign matter prior to adhesion.

2. Use a **J 25070** or equivalent to remove the old nameplate. Clean all the adhesive residue from the fender, wipe the surface dry with a clean lint-free towel prior to installing new nameplate.
3. Ensure full adhesion is made once the nameplate has been installed.

Tip: Clean and dry thoroughly the area where the emblem will be installed.

DOOR EMBLEM AND NAMEPLATE REPLACEMENT (H3)

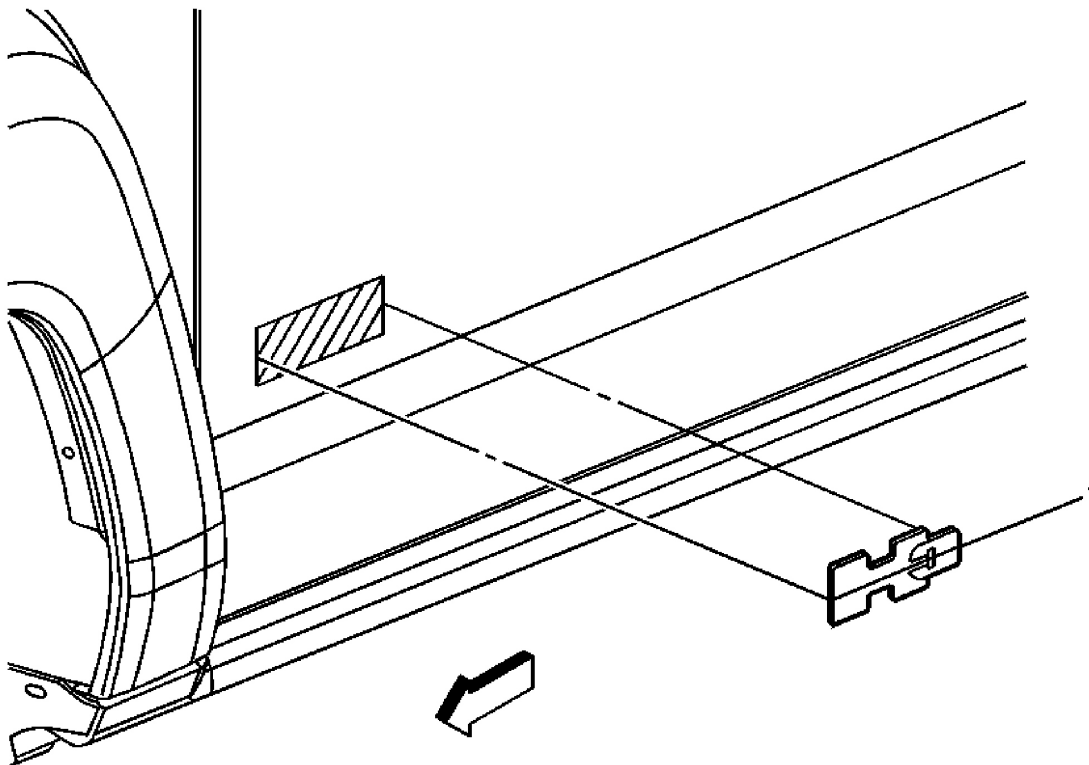

Fig. 4: View Of Door Emblem & Nameplate
 Courtesy of GENERAL MOTORS CORP.

Door Emblem and Nameplate Replacement (H3)

Callout	Component Name
Fastener Tightening Specifications: Refer to <u>Fastener Tightening Specifications</u>.	
	Side Front Door Emblem (Qty: 1)

1

1. When removing protective liners from adhesive backed nameplates, be careful not to touch the tape with hands and do not allow the tape to come in contact with dirt or any foreign matter prior to adhesion.
2. Use a **J 25070** or equivalent to remove the old nameplate. Clean all the adhesive residue from the fender, wipe the surface dry with a clean lint-free towel prior to installing new nameplate.
3. Ensure full adhesion is made once the nameplate has been installed.

Tip: Clean and dry thoroughly the area where the emblem will be installed.

ENDGATE EMBLEM AND NAMEPLATE REPLACEMENT (BASE)

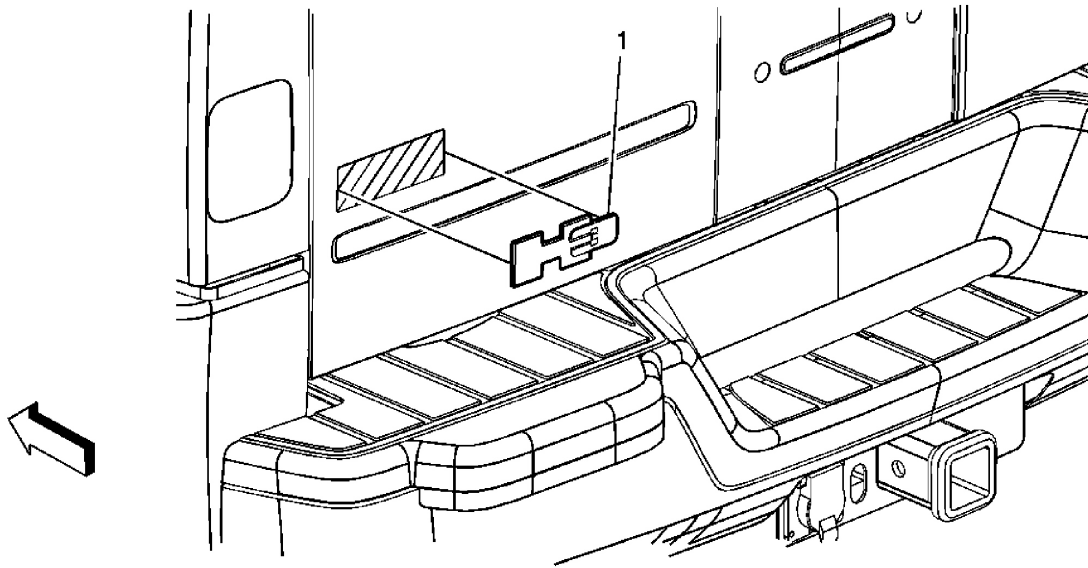

Fig. 5: Emblem/Nameplate Replacement - Endgate
 Courtesy of GENERAL MOTORS CORP.

Endgate Emblem and Nameplate Replacement (Base)

Callout	Component Name
Fastener Tightening Specifications: Refer to <u>Fastener Tightening Specifications</u> .	
	Endgate Emblem (Qty: 1) <ol style="list-style-type: none"> 1. When removing protective liners from adhesive backed nameplates, be careful not to touch the tape with hands and do not allow the tape to come in contact with dirt or any foreign matter prior to adhesion.

1

2. Use a **J 25070** or equivalent to remove the old nameplate. Clean all the adhesive residue from the fender, wipe the surface dry with a clean lint-free towel prior to installing new nameplate.
3. Ensure full adhesion is made once the nameplate has been installed.

Tip: Clean and dry thoroughly where the emblem will be installed.

FRONT WHEEL OPENING FLARE REPLACEMENT (BASE)

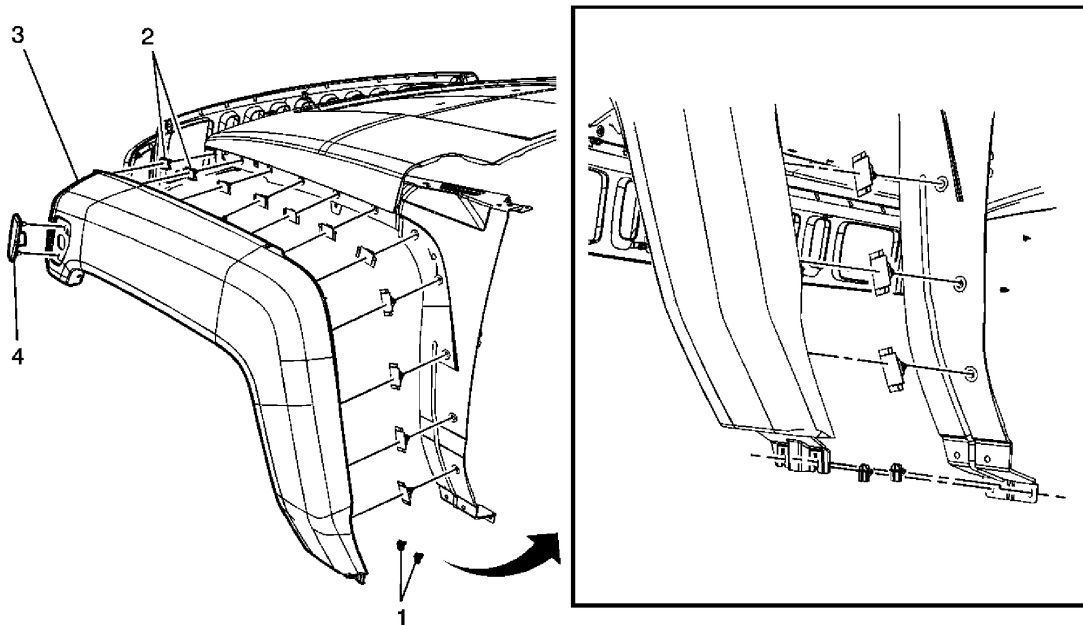

Fig. 6: Wheel Opening Flare Replacement - Front
 Courtesy of GENERAL MOTORS CORP.

Front Wheel Opening Flare Replacement (Base)

Callout	Component Name
Preliminary Procedures	
<ol style="list-style-type: none"> 1. Remove the front wheelhouse panel. Refer to <u>Wheelhouse Panel Replacement (Front)</u> or <u>Wheelhouse Panel Replacement (Rear)</u> . 2. Disconnect the front side marker lamp electrical connector from the marker lens housing. 	
	Pencil Brace Bolt (Qty: 2)

2007 Hummer H3

2007 ACCESSORIES & EQUIPMENT Exterior Trim - H3

1	NOTE: Refer to <u>Fastener Notice</u> . Tighten: 10 N.m (89 lb in)
2	Lower Fender Flare Retainer (Qty: 2)
3	Front Wheel Housing Opening Flare Retainer (Qty: 11) Procedure <ol style="list-style-type: none">1. Pull the flare away from the vehicle slightly, use small needle nose pliers to depress the tabs on the retainers.2. Pull front flare outward at the rear then rearward to release from under the edge of the front grille.3. Transfer the front marker lamp lens housing to the new front flare.
4	Front Wheel Housing Opening Flare Assembly

FRONT WHEEL OPENING FLARE REPLACEMENT (WITH BRM AND RHD)

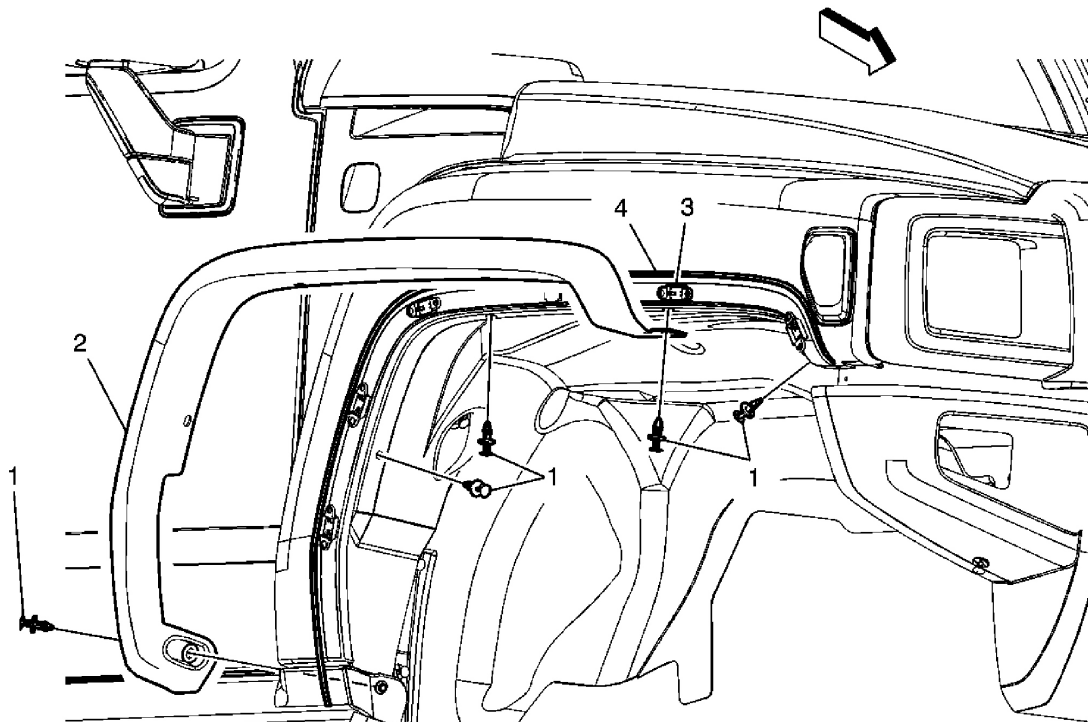

Fig. 7: View Of Front Wheel Opening Flare (With BRM & RHD)
Courtesy of GENERAL MOTORS CORP.

Front Wheel Opening Flare Replacement (with BRM and RHD)

Callout	Component Name
<p>NOTE: Refer to <u>Exterior Trim Emblem Removal Notice</u> .</p>	
<p>Preliminary Procedures</p> <ol style="list-style-type: none"> 1. The component part and surface should be 21°C (70°F) prior to installation. The vehicle should remain at 21°C (70°F) for one hour after assembly to allow the adhesive to develop sufficient bond strength. 2. Clean the old adhesive tape from the flare and wipe the surface with a clean, dry lint-free towel prior to installing the front flare. 3. When removing protective liners from the adhesive tape, be careful not to touch the tape with the hands and do not allow the tape to come in contact with dirt or any foreign matter prior to adhesion. 4. Remove either the LF or RF front wheelhouse panel. Refer to <u>Wheelhouse Panel Replacement (Front)</u> or <u>Wheelhouse Panel Replacement (Rear)</u> . 	
<p>1</p>	<p>RH Front Flare Retainer (Qty: 6) Tip:</p> <ol style="list-style-type: none"> 1. Disengage the bottom retainers. 2. Using a plastic flat-bladed tool, release the adhesive tape from the flare. 3. Pull the flare outward in order to release the outer flare retainers.
<p>2</p>	<p>RH Front Flare Assembly (LH Similar)</p>
<p>3</p>	<p>RH Front Flare Retainer (Qty: 6)</p>
<p>4</p>	<p>Double Sided Adhesive Tape Tip: Remove the adhesive tape backing only after the flare assembly is secured to the vehicle. Completely wet-out the entire outer periphery of the flare.</p>

REAR WHEEL OPENING FLARE REPLACEMENT (BASE REAR DOOR)

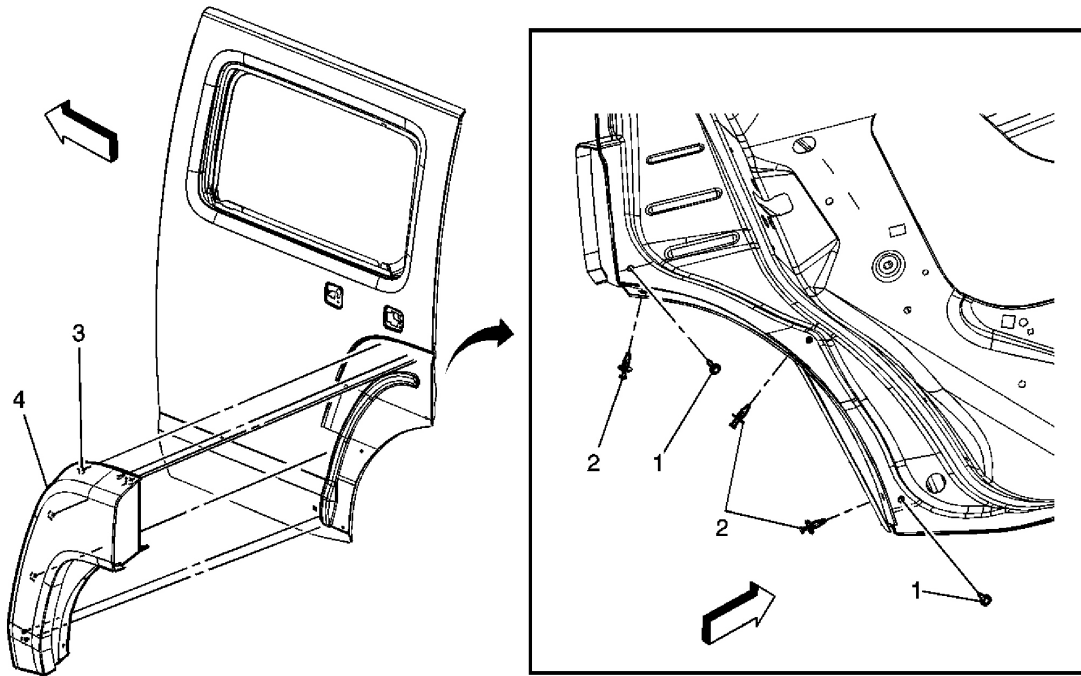

Fig. 8: Wheel Opening Flare Replacement - Rear (Door Side)
 Courtesy of GENERAL MOTORS CORP.

Rear Wheel Opening Flare Replacement (Base Rear Door)

Callout	Component Name
Preliminary Procedure	
1. Open either the RR or LR door in order to access the rear side door flare attachment screws and retainers. 2. Close the door prior to removing the flare assembly from the door.	
1	Rear Side Door Flare Screw (Qty: 2) NOTE: Refer to Fastener Notice . Tighten: 2 N.m (18 lb in)
2	Push Pin Retainer (Qty: 3)
3	Wheelhouse Molding Retainer (Qty: 5) Tip: Carefully pull straight outward on the flare to release the retainers from the door.
4	Rear Side Door Flare Assembly

REAR WHEEL OPENING FLARE REPLACEMENT (BASE REAR BODY)

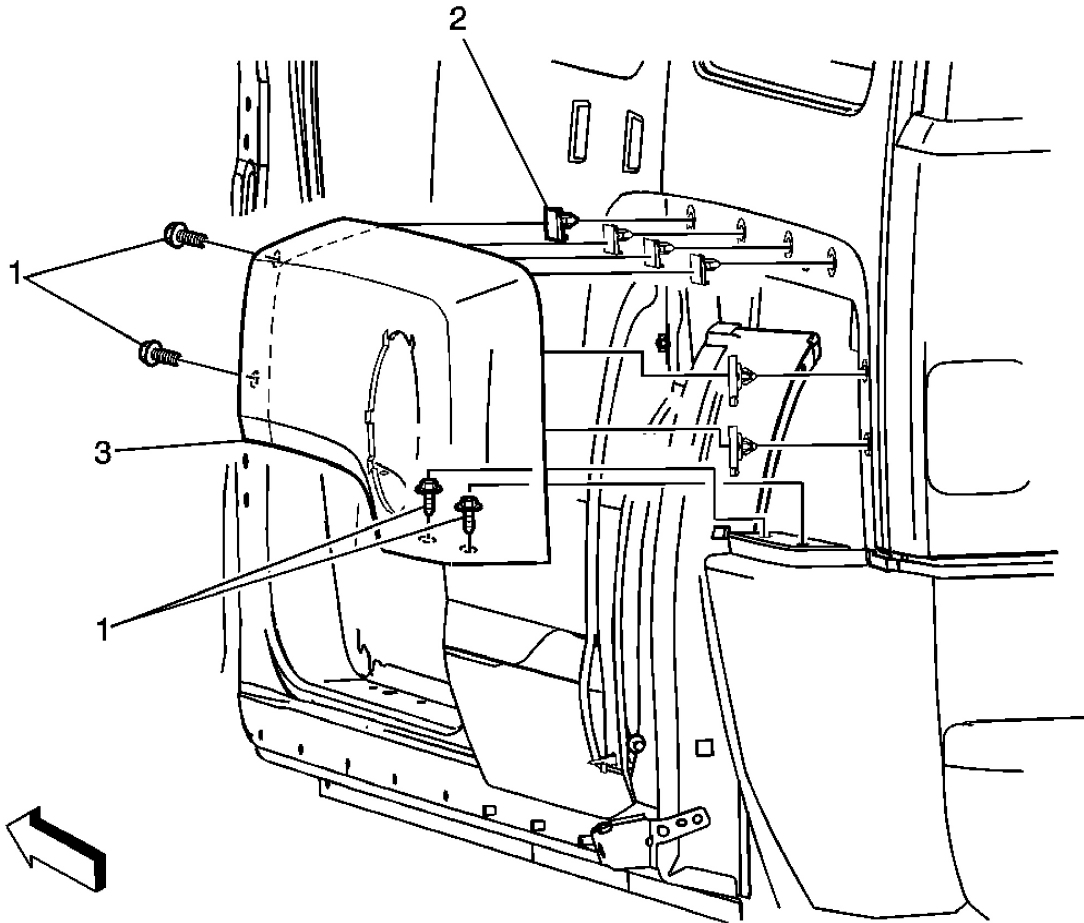

Fig. 9: Wheel Opening Flare Replacement - Rear (Wheelhouse)
 Courtesy of GENERAL MOTORS CORP.

Rear Wheel Opening Flare Replacement (Base Rear Body)

Callout	Component Name
<p>Preliminary Procedure</p> <ol style="list-style-type: none"> 1. Remove the rear wheelhouse panel. Refer to <u>Wheelhouse Panel Replacement (Front)</u> or <u>Wheelhouse Panel Replacement (Rear)</u> . 2. Remove the fuel filler pocket. Refer to <u>Fuel Tank Filler Pipe Housing Replacement</u> . 	
	<p>Rear Wheel Opening Flare Bolt (Qty: 4)</p> <p>NOTE:</p>

2007 Hummer H3

2007 ACCESSORIES & EQUIPMENT Exterior Trim - H3

1	Refer to Fastener Notice . Tighten: 9 N.m (80 lb in)
2	Rear Wheel Opening Flare Retainer (Qty: 6) Tip: Use side cutters to clip the ends of the retainers for removal.
3	Rear Wheel Opening Flare Assembly

REAR WHEEL OPENING FLARE REPLACEMENT (REAR DOOR W/BRM AND RHD)

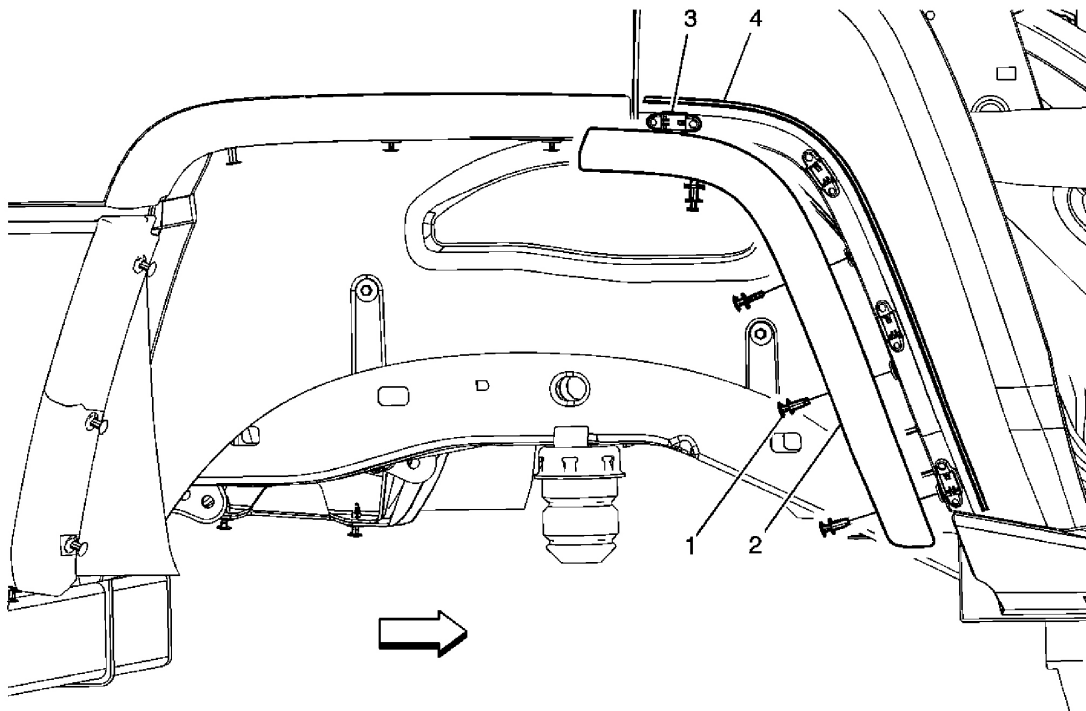

Fig. 10: Identifying Rear Wheel Opening Flare (Rear Door w/BRM & RHD)
Courtesy of GENERAL MOTORS CORP.

Rear Wheel Opening Flare Replacement (Rear Door w/BRM and RHD)

Callout	Component Name
---------	----------------

NOTE:

Refer to **Exterior Trim Emblem Removal Notice** .

Preliminary Procedures

1. The component part and surface should be 21°C (70°F) prior to installation. The vehicle should remain at 21°C (70°F) for one hour after assembly to allow the

2007 Hummer H3

2007 ACCESSORIES & EQUIPMENT Exterior Trim - H3

adhesive to develop sufficient bond strength.

2. Clean the old adhesive tape from the door flare and wipe the surface with a clean, dry lint-free towel prior to installing the door flare.
3. When removing protective liners from the adhesive tape, be careful not to touch the tape with the hands and do not allow the tape to come in contact with dirt or any foreign matter prior to adhesion.

1	Rear Door Flare Retainer (Qty: 4) Tip: <ol style="list-style-type: none">1. Disengage the inner retainers.2. Using a plastic flat-bladed tool, release the adhesive tape from the flare.3. Pull the flare outward in order to release the outer flare retainers.
2	Rear Door Flare (LH Similar)
3	Rear Door Flare Retainer (Qty: 4)
4	Double Sided Adhesive Tape Tip: Remove the adhesive tape backing only after the flare assembly is secured to the vehicle. Completely wet-out the entire outer periphery of the flare.

REAR WHEEL OPENING FLARE REPLACEMENT (REAR BODY W/BRM AND RHD)

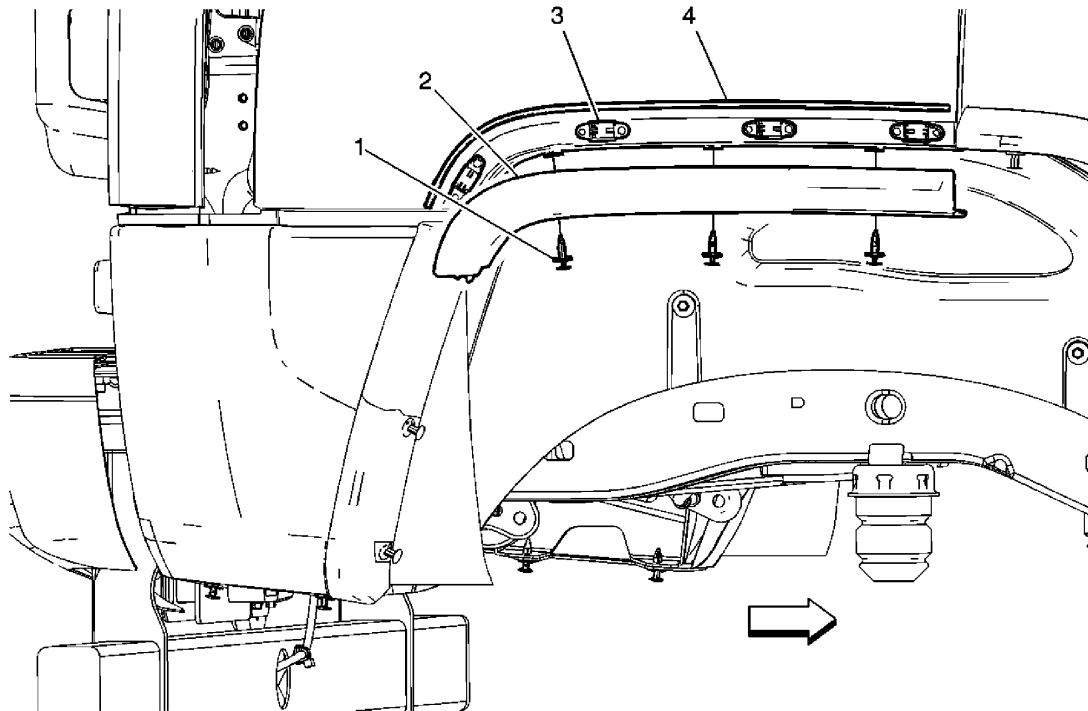

Fig. 11: Identifying Rear Wheel Opening Flare (Rear Body w/BRM & RHD)
 Courtesy of GENERAL MOTORS CORP.

Rear Wheel Opening Flare Replacement (Rear Body w/BRM and RHD)

Callout	Component Name
<p>NOTE:</p>	
<p>Refer to <u>Exterior Trim Emblem Removal Notice</u> .</p>	
<p>Preliminary Procedures</p>	
<ol style="list-style-type: none"> 1. The component part and surface should be 21°C (70°F) prior to installation. The vehicle should remain at 21°C (70°F) for one hour after assembly to allow the adhesive to develop sufficient bond strength. 2. Clean the old adhesive tape from the body flare and wipe the surface with a clean, dry lint-free towel prior to installing the body flare. 3. When removing protective liners from the adhesive tape, be careful not to touch the tape with the hands and do not allow the tape to come in contact with dirt or any foreign matter prior to adhesion. 	

Rear Body Flare Retainer (Qty: 3)

Tip:

2007 Hummer H3

2007 ACCESSORIES & EQUIPMENT Exterior Trim - H3

1	<ol style="list-style-type: none"> 1. Disengage the inner retainers. 2. Using a plastic flat-bladed tool, release the adhesive tape from the flare. 3. Pull the flare outward in order to release the body flare retainers.
2	Rear Body Flare (LH Similar)
3	Rear Body Flare Retainer (Qty: 4)
4	<p>Double Sided Adhesive Tape</p> <p>Tip: Remove the adhesive tape backing only after the flare assembly is secured to the vehicle. Completely wet-out the entire outer periphery of the flare.</p>

REAR WHEEL OPENING FLARE REPLACEMENT (REAR BUMPER W/BRM AND RHD)

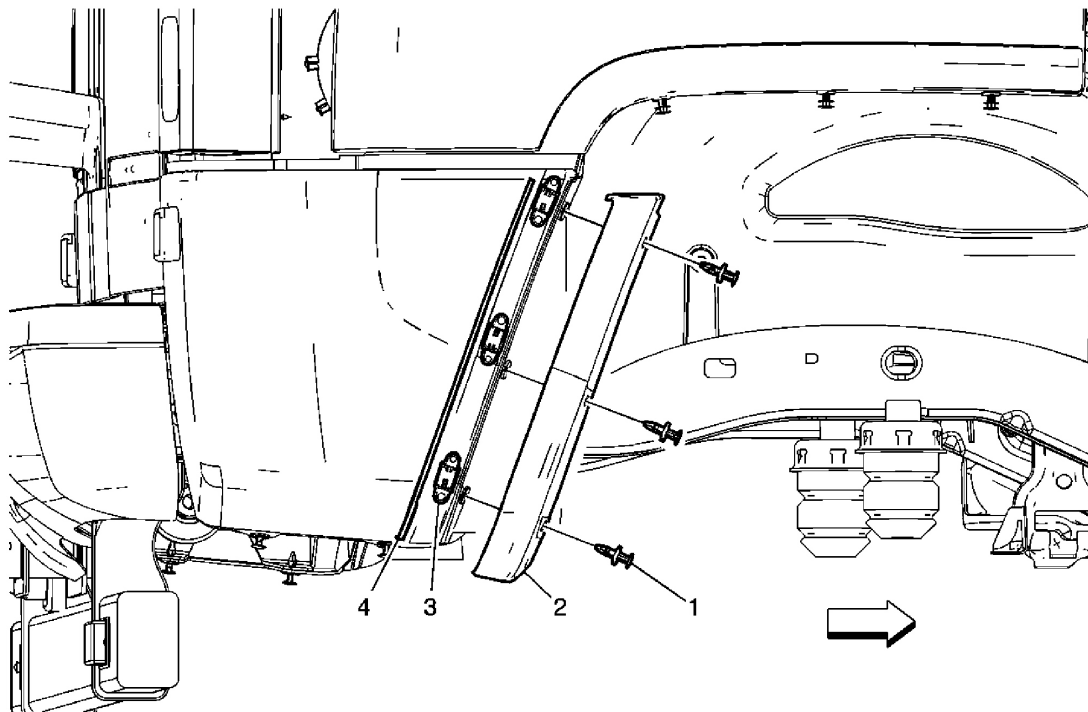

Fig. 12: Identifying Rear Wheel Opening Flare (Rear Bumper w/BRM & RHD)
 Courtesy of GENERAL MOTORS CORP.

Rear Wheel Opening Flare Replacement (Rear Bumper w/BRM and RHD)

Callout	Component Name
<p>NOTE: Refer to Exterior Trim Emblem Removal Notice .</p>	

Preliminary Procedures

1. The component part and surface should be 21°C (70°F) prior to installation. The vehicle should remain at 21°C (70°F) for one hour after assembly to allow the adhesive to develop sufficient bond strength.
2. Clean the old adhesive tape from the bumper flare and wipe the surface with a clean, dry lint-free towel prior to installing the bumper flare.
3. When removing protective liners from the adhesive tape, be careful not to touch the tape with the hands and do not allow the tape to come in contact with dirt or any foreign matter prior to adhesion.

1	<p>Rear Bumper Flare Retainer (Qty: 3)</p> <p>Tip:</p> <ol style="list-style-type: none"> 1. Disengage the inner retainers. 2. Using a plastic flat-bladed tool, release the adhesive tape from the flare. 3. Pull the flare outward in order to release the bumper flare retainers.
2	Rear Bumper Flare (LH Similar)
3	Rear Bumper Flare Retainer (Qty: 3)
4	<p>Double Sided Adhesive Tape</p> <p>Tip: Remove the adhesive tape backing only after the flare assembly is secured to the vehicle. Completely wet-out the entire outer periphery of the flare.</p>

FRONT BUMPER LOWER FASCIA GRILLE REPLACEMENT

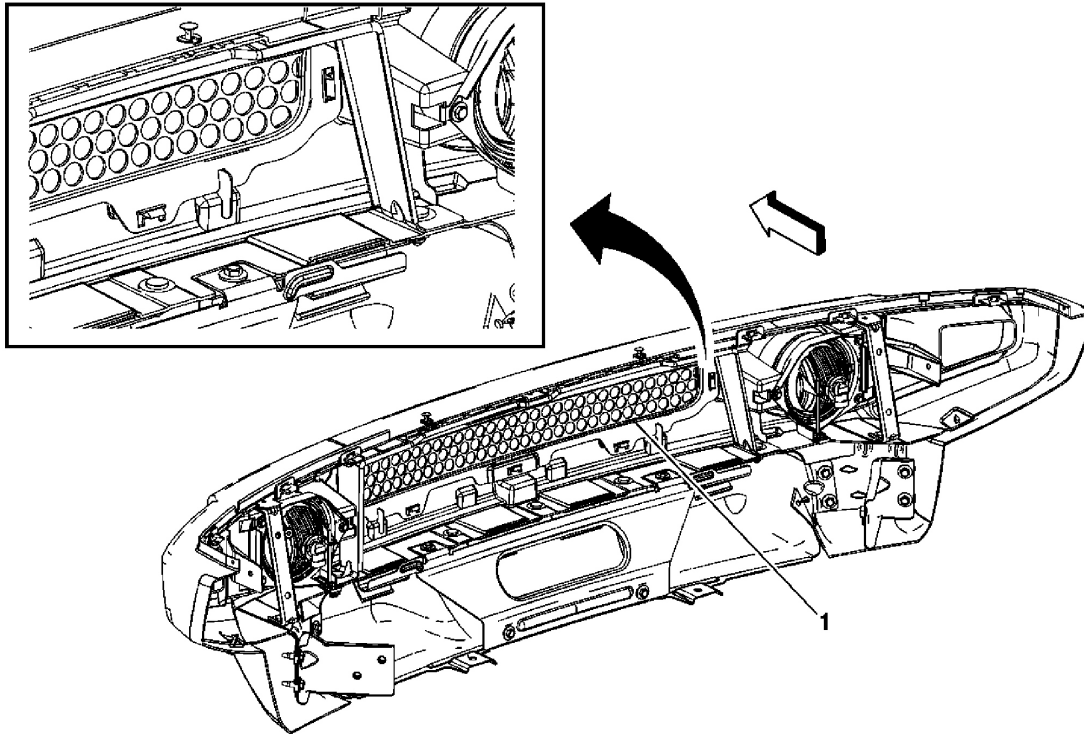

Fig. 13: View Of Front Bumper Lower Fascia Grille
 Courtesy of GENERAL MOTORS CORP.

Front Bumper Lower Fascia Grille Replacement

Callout	Component Name
Preliminary Procedure: Remove the front bumper. Refer to Front Bumper Fascia Replacement .	
1	Front Bumper Fascia Lower Grille Tip: Release the tabs to dislocate the grille from the filler assembly.

GRILLE REPLACEMENT

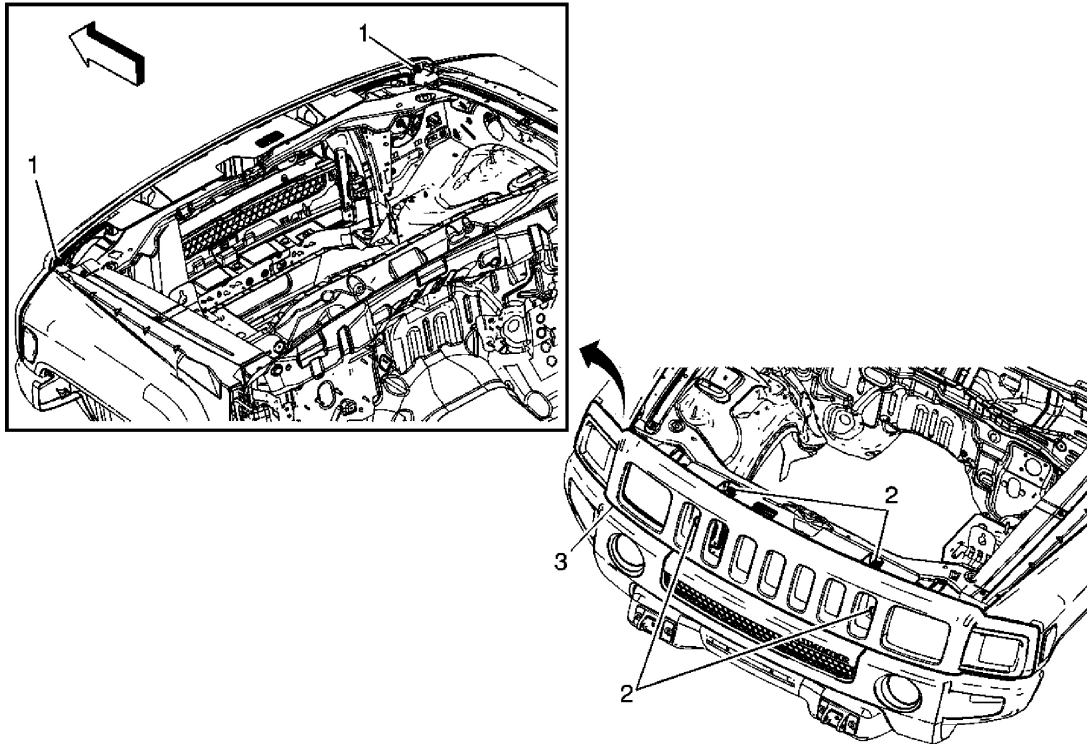

Fig. 14: Identifying Grille
 Courtesy of GENERAL MOTORS CORP.

Grille Replacement

Callout	Component Name
<p>Preliminary Procedure: Remove the brush/grille guard (if equipped). Refer to <u>Grille Guard/Brush Guard Replacement (Base)</u> or <u>Grille Guard/Brush Guard Replacement (H3X)</u>.</p>	
<p>1</p>	<p>Radiator Grille Nuts (Qty: 2)</p> <p>NOTE: Refer to <u>Fastener Notice</u> .</p> <p>Tighten: 7 N.m (62 lb in)</p>
<p>2</p>	<p>Radiator Grille Screws (Qty: 4)</p> <p>Tighten: 7 N.m (62 lb in)</p>
	<p>Radiator Grille</p> <p>Tip:</p>

3

- Pull outward evenly to release the retainer tabs from the retention clips around the headlamps.
- Pull outward evenly to release the retainer tabs from the retention clips at the center upper and lower grille area.
- Transfer the radiator grille support assembly as needed.

GRILLE GUARD/BRUSH GUARD REPLACEMENT (BASE)

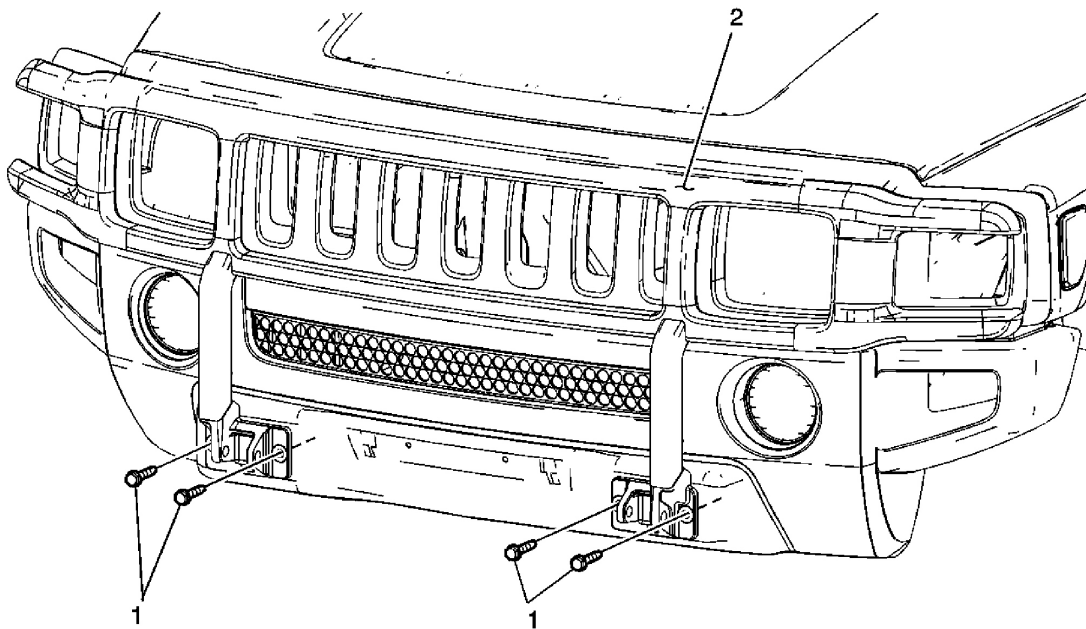

Fig. 15: Grille Guard/Brush Guard Replacement
 Courtesy of GENERAL MOTORS CORP.

Grille Guard/Brush Guard Replacement (Base)

Callout	Component Name
<p>NOTE: Refer to <u>Fastener Notice</u> .</p> <p>Fastener Tightening Specifications: Refer to <u>Fastener Tightening Specifications</u>. Preliminary Procedure: Remove the front tow hooks. Refer to <u>Front Tow Hook Replacement</u> .</p>	
<p>1</p>	<p>Bar Bolts, Front Bumper Impact (Qty: 4) Tip: Support the radiator grille guard prior to removing the bolts.</p>

	Tighten: 50 N.m (37 lb ft)
2	Guard Assembly, Radiator Grille

GRILLE GUARD/BRUSH GUARD REPLACEMENT (H3X)

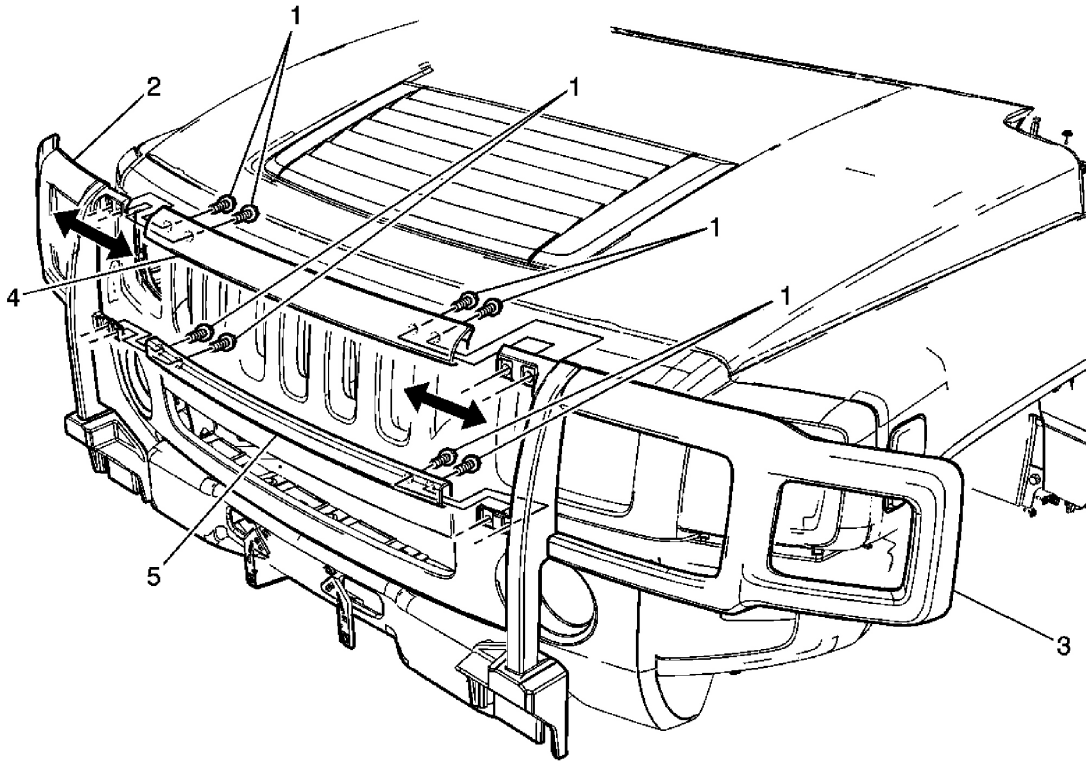

Fig. 16: Identifying Grille Guard/Brush Guard
 Courtesy of GENERAL MOTORS CORP.

Grille Guard/Brush Guard Replacement (H3X)

Callout	Component Name
Preliminary Procedure: Remove the front tow hooks. Refer to Front Tow Hook Replacement . Tip: Support the radiator grille/brush guard prior to removing the impact bar bolts.	
1	Radiator Grille Guard Assembly Bolts (Qty: 8) NOTE: Refer to Fastener Notice . Tighten: Tighten the bolts to 10 N.m (89 lb in)

2007 Hummer H3

2007 ACCESSORIES & EQUIPMENT Exterior Trim - H3

2	Radiator Grille Outer (RH) Guard Tip: Slide the outer grille into the upper and lower grille guard prior to installing the bolts.
3	Radiator Grille Outer (LH) Guard Tip: Slide the outer grille into the upper and lower grille guard prior to installing the bolts.
4	Radiator Grille Upper Guard
5	Radiator Grille Lower Guard

HOOD AIR GRILLE REPLACEMENT

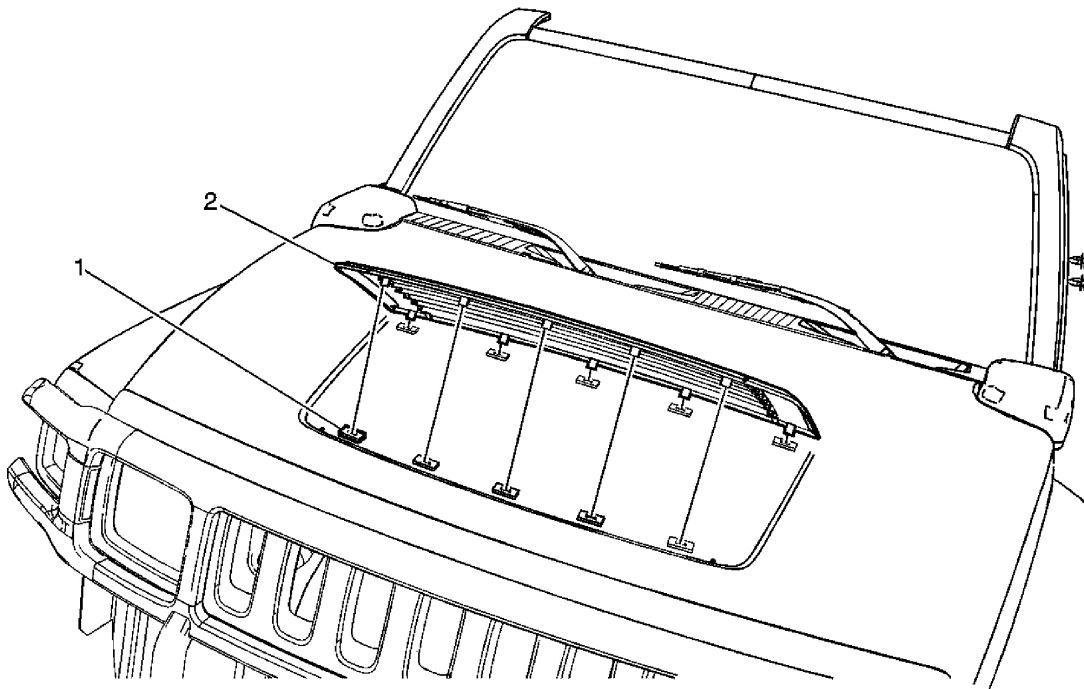

Fig. 17: Grille Replacement - Hood Air
Courtesy of GENERAL MOTORS CORP.

Hood Air Grille Replacement

Callout	Component Name
Fastener Tightening Specifications: Refer to <u>Fastener Tightening Specifications</u> .	
1	Clips, Integral Retention (Qty: 10) Tip: Evenly pull the hood air grille panel at the outer edges upward to release the 10 tabs from the hood retention clips.
2	Grille Assembly - Hood Air

ROCKER PANEL MOLDING REPLACEMENT

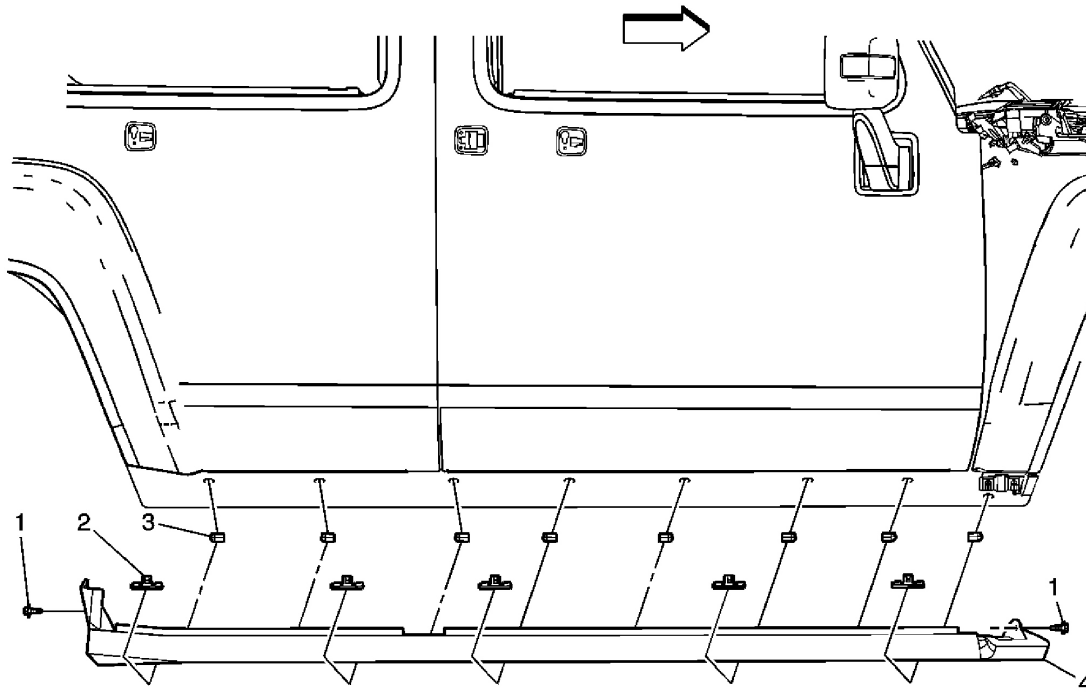

Fig. 18: Molding Replacement - Rocker Panel
 Courtesy of GENERAL MOTORS CORP.

Rocker Panel Molding Replacement

Callout	Component Name
Fastener Tightening Specifications: Refer to <u>Fastener Tightening Specifications</u> .	
NOTE: Refer to <u>Fastener Notice</u> .	
1	Screws, Rocker Panel (Qty: 2) Tighten: 2 N.m (18 lb in)
2	Retainers, Lower Rocker Panel (Qty: 5) Tip: Release the lower 5 retainers from the rocker by pulling panel downward.
3	Retainers, Upper Rocker Panel (Qty: 8) Tip: Release the upper 8 retainers from the rocker by pulling the panel outward.
4	Panel, Lower Rocker

WINDSHIELD SIDE REVEAL MOLDING REPLACEMENT

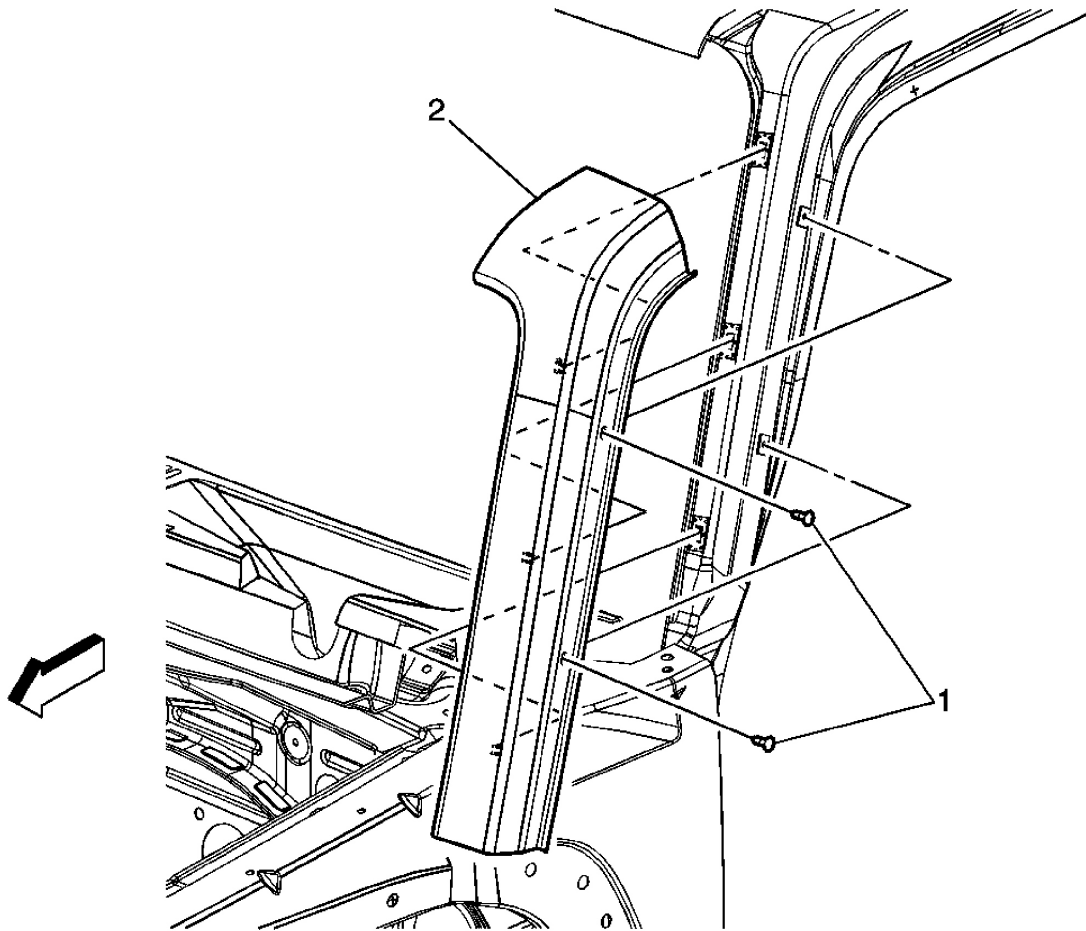

Fig. 19: Windshield Pillar Reveal Molding Replacement
 Courtesy of GENERAL MOTORS CORP.

Windshield Side Reveal Molding Replacement

Callout	Component Name
<p>NOTE: Refer to <u>Fastener Notice</u> .</p>	
<p>Fastener Tightening Specifications: Refer to <u>Fastener Tightening Specifications</u>.</p>	
<p>Preliminary Procedure</p>	
<p>1. Remove the non functional air inlet grille panel. Refer to <u>Non-Functional Air Inlet Grille Panel Replacement</u> .</p>	

- Open either the left or right front door and release the auxiliary weatherstrip up to the roof header to access the windshield side reveal molding screws.

1	Screws, Windshield Reveal Molding (Qty: 2) Tip: Pull reveal molding forward to release the tabs from the integral retention clips. Tighten: 2 N.m (18 lb in)
2	Molding, Windshield Reveal

SPARE WHEEL STOWAGE OUTER COVER REPLACEMENT

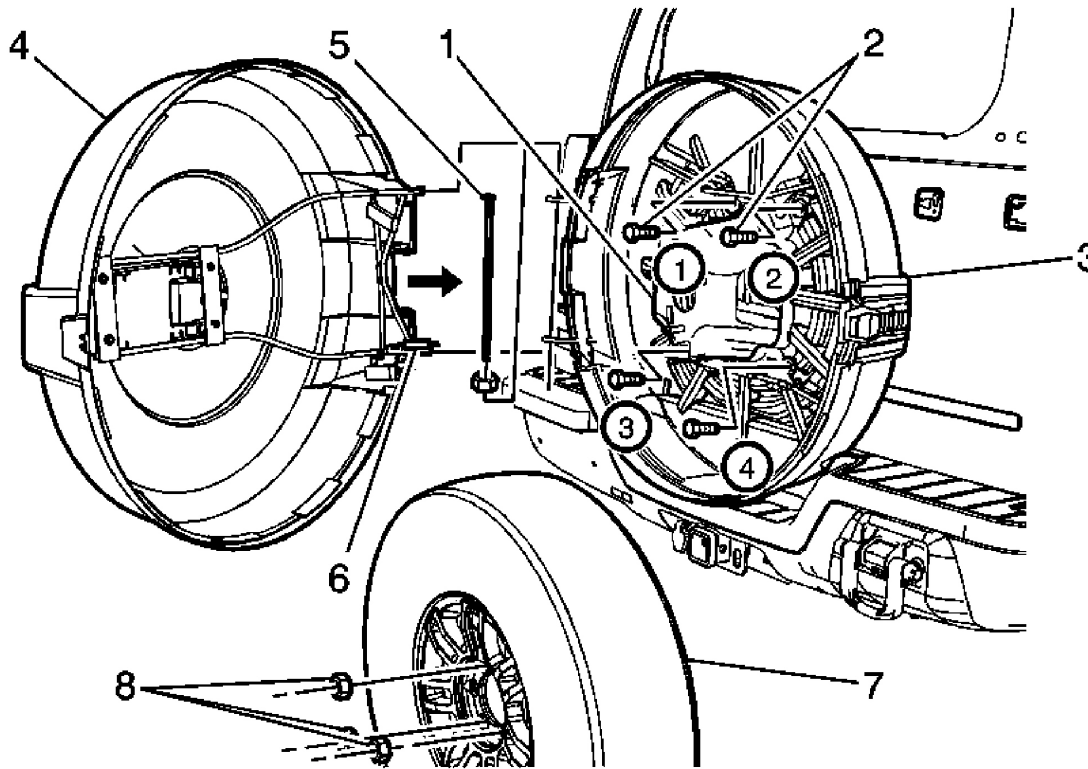

Fig. 20: Identifying Spare Wheel Stowage Outer Cover
 Courtesy of GENERAL MOTORS CORP.

Spare Wheel Stowage Outer Cover Replacement

Callout	Component Name
---------	----------------

Preliminary Procedures

- Remove the spare tire from the spare tire carrier.

2007 Hummer H3

2007 ACCESSORIES & EQUIPMENT Exterior Trim - H3

2. Remove the 4 nuts from the spare tire carrier studs.
3. Remove the spare tire carrier.
4. Remove the 4 spare tire carrier studs from the liftgate.

1	Spare Wheel Carrier Assembly
2	<p>Spare Wheel Carrier Bolt (Qty: 4)</p> <p>NOTE: Refer to <u>Fastener Notice</u> .</p> <p>Tip:</p> <ul style="list-style-type: none">• Apply LOCTITE® Blue, 242 to the threads prior to installing the spare wheel carrier bolts to the liftgate.• Tighten the 4 bolts in sequence as shown. <p>Tighten: 50 N.m (37 lb ft)</p>
3	Spare Wheel Stowage Inner Cover Assembly
4	<p>Spare Wheel Stowage Outer Cover Assembly</p> <p>Procedure</p> <ol style="list-style-type: none">1. Align the outer cover hinge to the inner cover hinge.2. If the outer cover sags, remove the 4 bolts holding the outer hinge to the outer cover.3. Place the outer cover in the Full Open position and swing the outer hinge to the closed position.4. Measure from the floor to the top bar of the outer hinge at the outermost vertical mounting plate.5. Using the palm of the hand, pry upward on the outer hinge and re-measure from the floor to the same location as previously measured on the outer hinge.6. Continue using the previous adjustment steps until the proper amount of height of the hinge outer is achieved to obtain the proper alignment of the Inner to Outer panels.
5	<p>Spare Wheel Carrier Hinge Bolt</p> <p>Tighten: 10 N.m (89 lb in)</p>

2007 Hummer H3

2007 ACCESSORIES & EQUIPMENT Exterior Trim - H3

6	Gas Strut Bolt Tighten: 10 N.m (89 lb in)
7	Spare Wheel Assembly
8	Spare Wheel Assembly Nut (Qty: 3) Tighten: 136 N.m (100 lb ft)