

2007 Hummer H3

2007 ACCESSORIES & EQUIPMENT Displays and Gages - H3

2007 ACCESSORIES & EQUIPMENT

Displays and Gages - H3

SPECIFICATIONS

FASTENER TIGHTENING SPECIFICATIONS

Fastener Tightening Specifications

Application	Specification	
	Metric	English
Instrument Panel Accessory Switch Assembly Screws	2 N.m	18 lb in
Instrument Panel Cluster Assembly Screws	2 N.m	18 lb in

FUEL LEVEL SPECIFICATIONS

The information in this table is intended for use with the **J 33431-C** Signal Generator and Instrument Panel Tester. The fuel level sensor values represent the test values to be used on the Signal Generator to drive the fuel gage display to the indicated positions. Vehicles that require more than one fuel level sensor calculate gage position from many possible resistance combinations of fuel levels between the two tanks. Therefore, the values in the table may not correlate directly to readings taken from the vehicle primary or secondary sending units.

The values in this table are approximate values based on information obtained from properly operating vehicles. Actual results may vary slightly.

Fuel Level Specifications

Fuel Gage Display	Resistance	Fuel Level	Fuel Remaining
19.8 Gallon Tank			
E	40-70 ohms	0-10%	0-8.5 L (0-2.3 gal)
1/4	110 ohms	28%	23.4 L (6.2 gal)
1/2	143 ohms	51%	38.3 L (10.1 gal)
3/4	181 ohms	74%	53.2 L (14.1 gal)
F	215-250 ohms	90-100%	68.1-75.7 L (18-20 gal)
Low Fuel Indicator On	63 ohms	7%	9.3 L (2.4 gal)

SCHEMATIC AND ROUTING DIAGRAMS

2007 Hummer H3

2007 ACCESSORIES & EQUIPMENT Displays and Gages - H3

INSTRUMENT CLUSTER SCHEMATICS

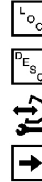
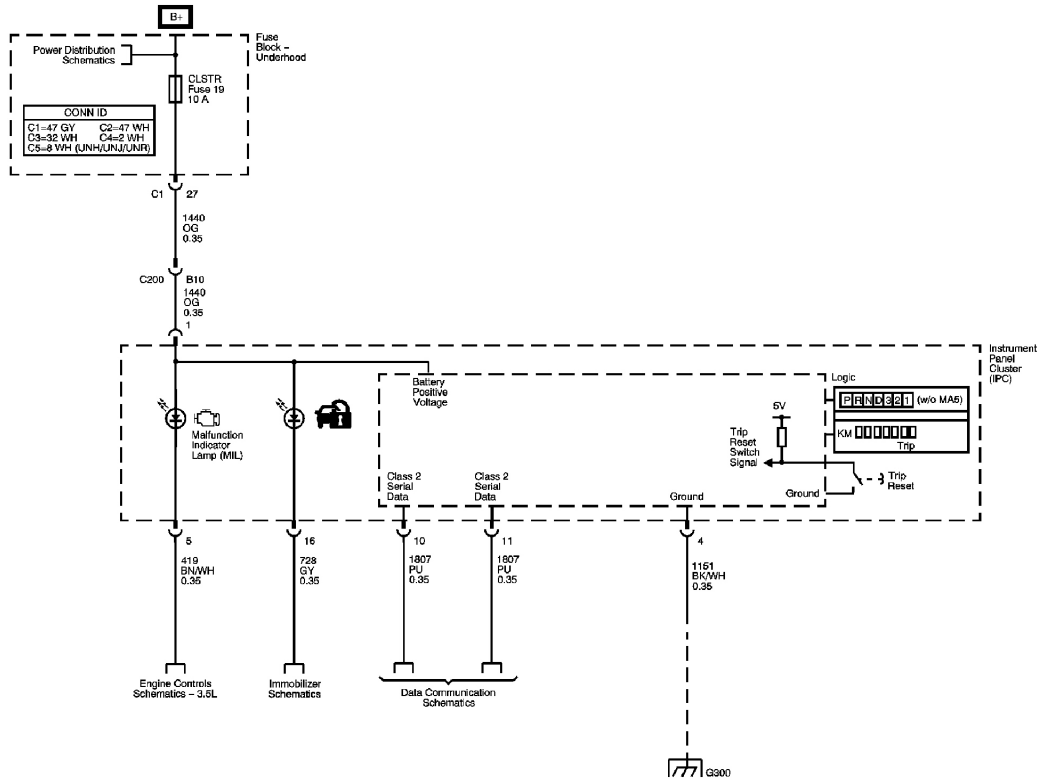

Fig. 1: Power, Ground, MIL and Security Schematic
 Courtesy of GENERAL MOTORS CORP.

2007 Hummer H3

2007 ACCESSORIES & EQUIPMENT Displays and Gages - H3

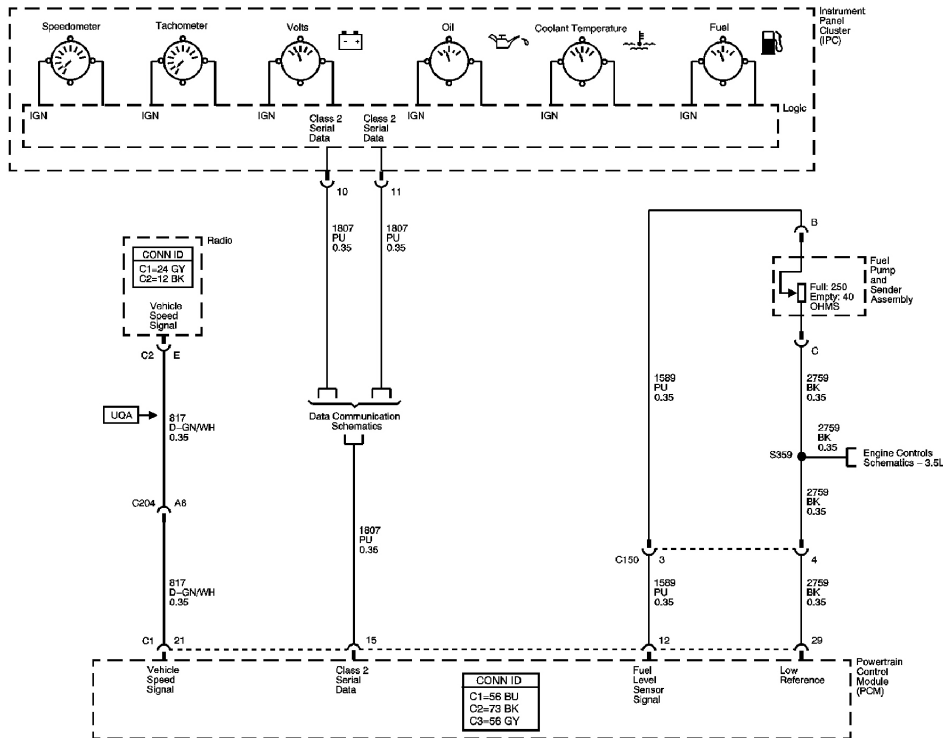

Fig. 2: Gages Schematic
 Courtesy of GENERAL MOTORS CORP.

2007 Hummer H3

2007 ACCESSORIES & EQUIPMENT Displays and Gages - H3

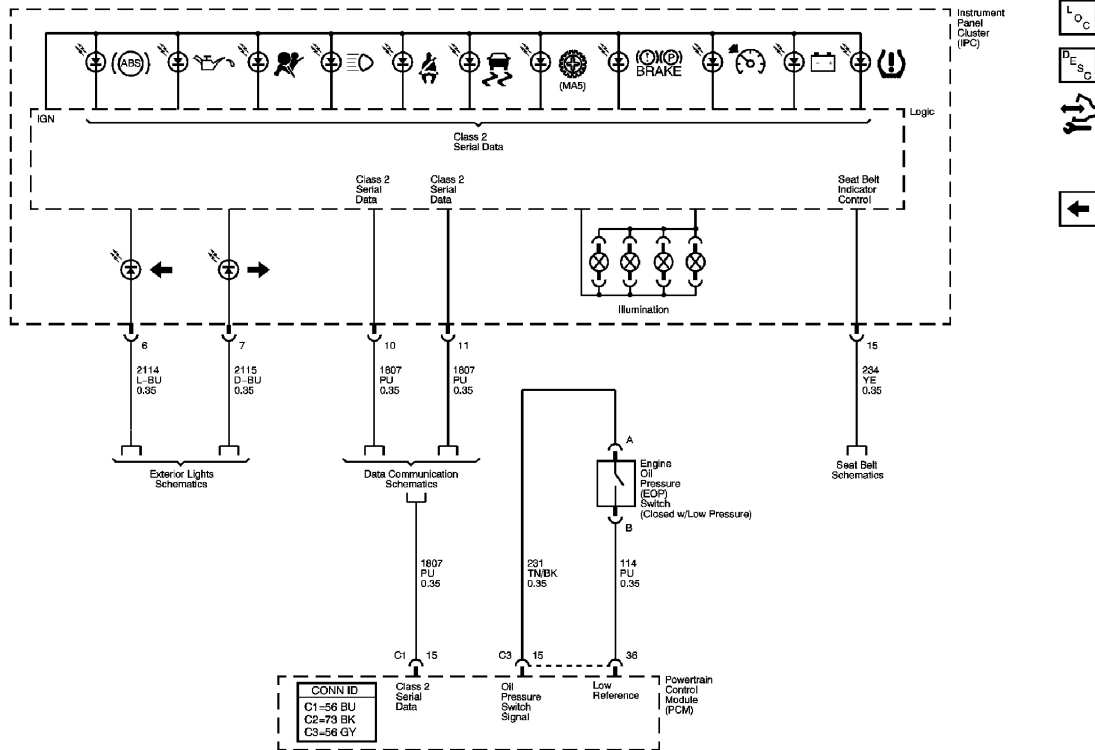

Fig. 3: Indicators Schematic
 Courtesy of GENERAL MOTORS CORP.

AUDIBLE WARNINGS SCHEMATICS

2007 Hummer H3

2007 ACCESSORIES & EQUIPMENT Displays and Gages - H3

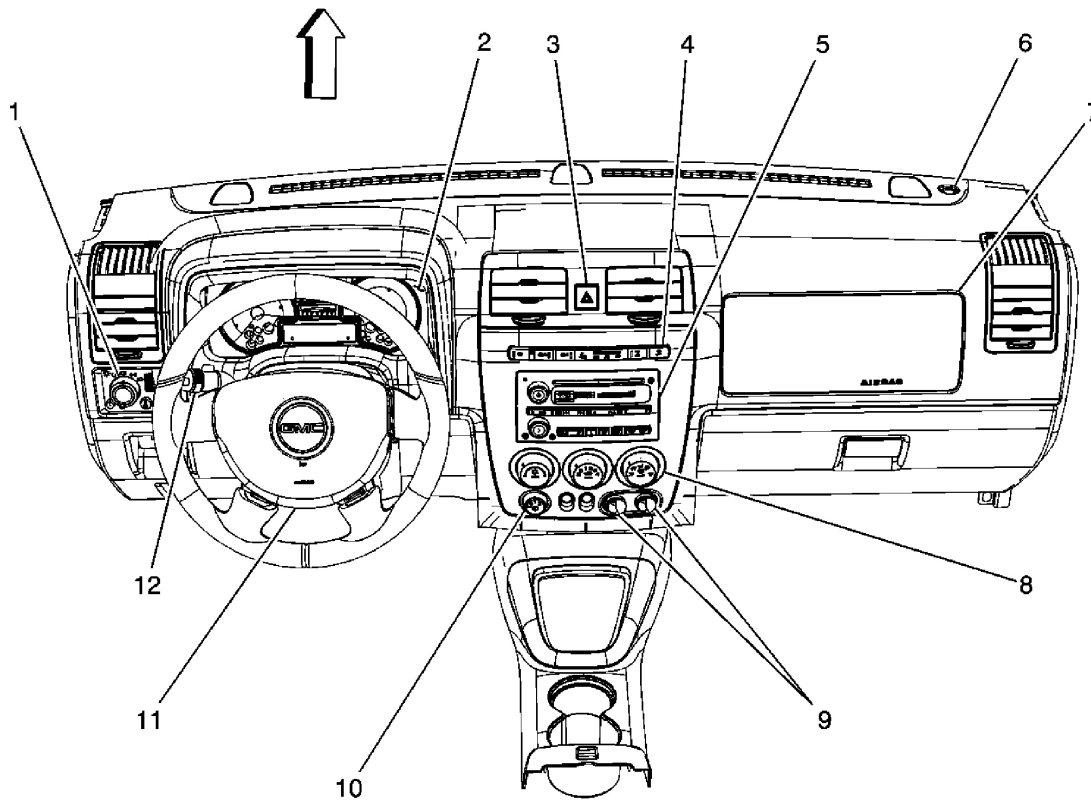

Fig. 5: Identifying I/P Harness Components
Courtesy of GENERAL MOTORS CORP.

Callouts For Fig. 5

Callout	Component Name
1	Headlamp Switch
2	Instrument Panel Cluster (IPC)
3	Hazard Switch
4	Accessory Switch
5	Radio
6	Ambient Light Sensor
7	Inflatable Restraint I/P Module
8	HVAC Control Module
9	Auxiliary Power Outlets - Front
10	Rear Window Wiper/Washer Switch
11	Inflatable Restraint Steering Wheel Module
12	Turn Signal/Multifunction Switch

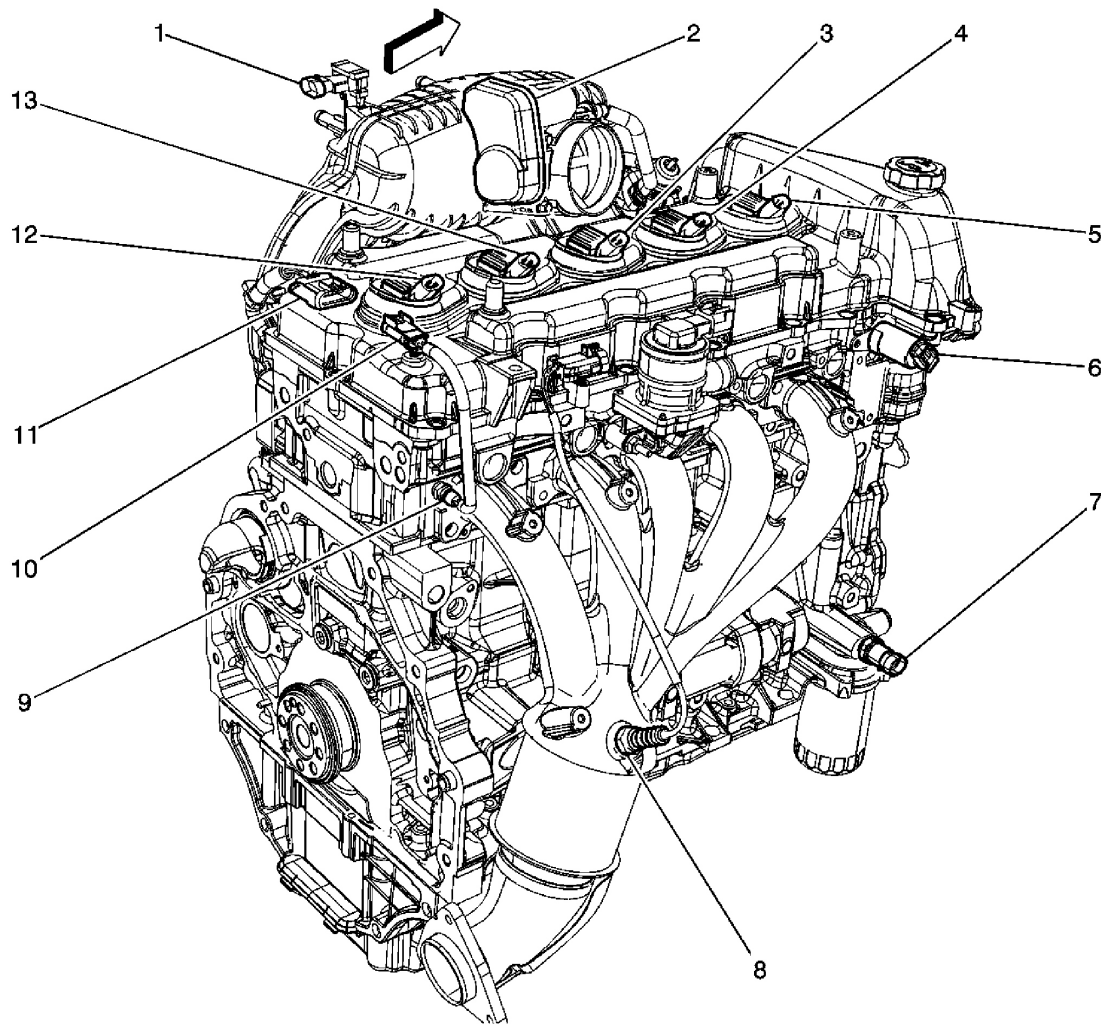

Fig. 6: Identifying Engine Components - Right Side (L52)
 Courtesy of GENERAL MOTORS CORP.

Callouts For Fig. 6

Callout	Component Name
1	Manifold Absolute Pressure (MAP) Sensor
2	Throttle Body
3	Ignition Coil 3
4	Ignition Coil 2
5	Ignition Coil 1
6	Camshaft Position (CMP) Actuator Solenoid - Bank 1 Exhaust
7	Engine Oil Pressure (EOP) Switch
8	Heated Oxygen Sensor (HO2S) 1

2007 Hummer H3

2007 ACCESSORIES & EQUIPMENT Displays and Gages - H3

9	Engine Coolant Temperature (ECT) Sensor
10	Engine Coolant Temperature (ECT) Sensor Connector
11	C101 Fuel Injector Harness to Engine Harness
12	Ignition Coil 5
13	Ignition Coil 4

DISPLAYS AND GAGES CONNECTOR END VIEWS

Engine Oil Pressure (EOP) Switch

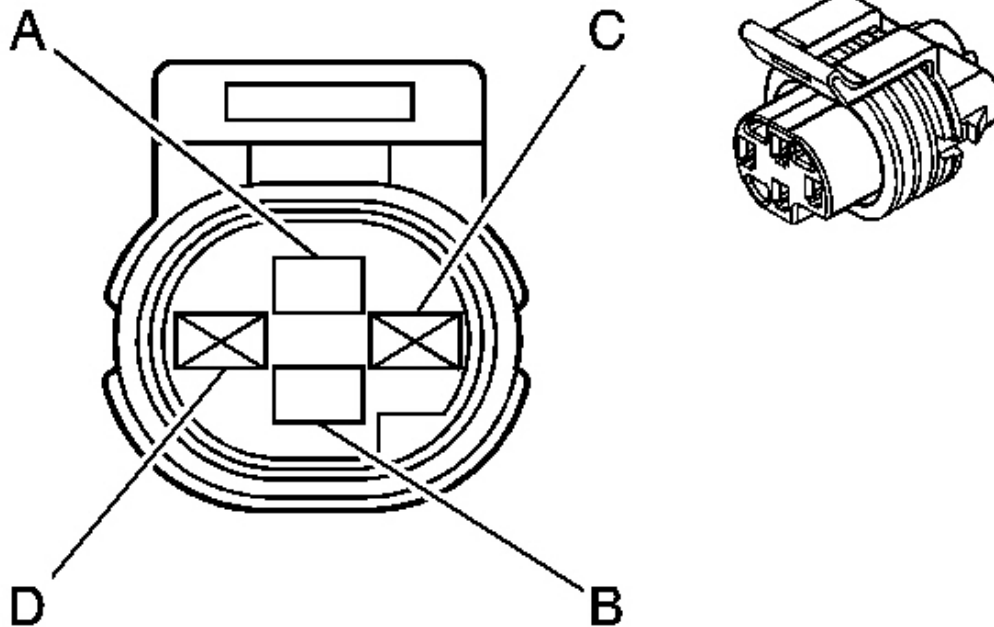

Fig. 7: Engine Oil Pressure (EOP) Switch Connector End View
Courtesy of GENERAL MOTORS CORP.

Engine Oil Pressure (EOP) Switch Connector Parts Information

Connector Part Information

- OEM: 12065400
- Service: 12126436

2007 Hummer H3

2007 ACCESSORIES & EQUIPMENT Displays and Gages - H3

- Description: 2-Way F Metri-Pack 150 Series, Sealed (L-GN)

Terminal Part Information

- Terminal/Tray: 12048074/2
- Core/Insulation Crimp: E/1
- Release Tool/Test Probe: 12094429/J-35616-2A (GY)

Engine Oil Pressure (EOP) Switch Connector Terminal Identification

Pin	Wire Color	Circuit No.	Function
A	TN/BK	231	Oil Pressure Switch Signal
B	PU	114	Low Reference
C	-	-	Not Available
D	-	-	Not Available

Instrument Panel Cluster (IPC)

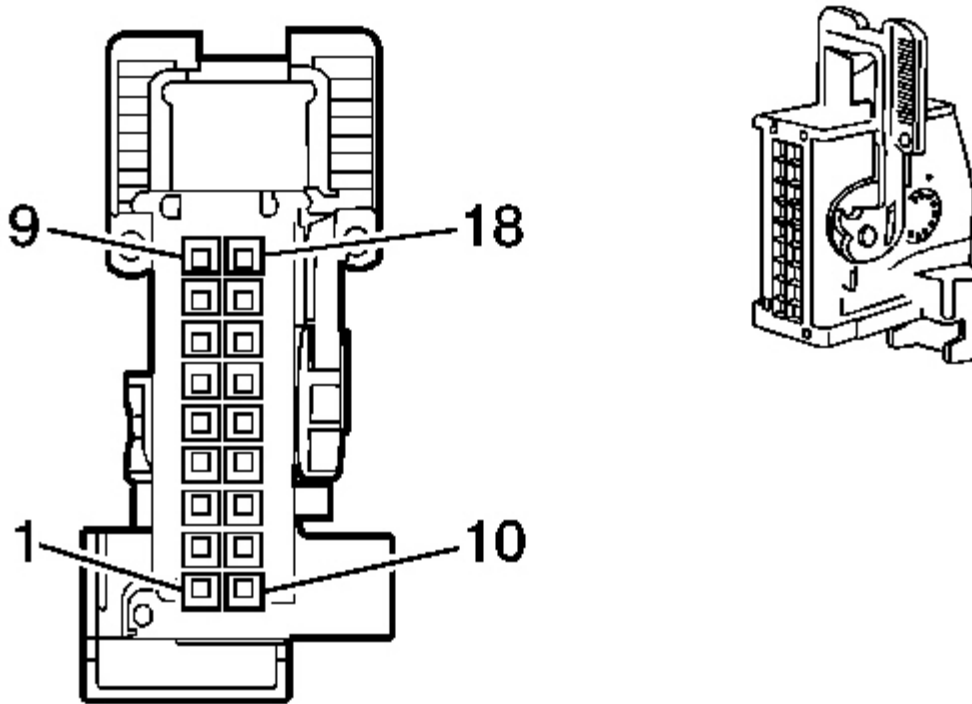

Fig. 8: Instrument Panel Cluster (IPC) Connector End Views
Courtesy of GENERAL MOTORS CORP.

Instrument Panel Cluster (IPC) Connector Parts Information

Connector Part Information

- OEM: 185304-1
- Service: 89046871
- Description: 18-Way F Micro Quadlok (BK)

Terminal Part Information

- Terminal/Tray: 144969-1
- Core/Insulation Crimp: See Terminal Kit
- Release Tool/Test Probe: See Terminal Kit

2007 Hummer H3

2007 ACCESSORIES & EQUIPMENT Displays and Gages - H3

Instrument Panel Cluster (IPC) Connector Terminal Identification

Pin	Wire Color	Circuit No.	Function
1	OG	1440	Battery Positive Voltage
2-3	-	-	Not Used
4	BK/WH	1151	Ground
5	BN/WH	419	MIL Control
6	L-BU	2114	Left Turn Signal Lamp Supply Voltage
7	D-BU	2115	Right Turn Signal Lamp Supply Voltage
8-9	-	-	Not Used
10	PU	1807	Class 2 Serial Data
11	PU	1807	Class 2 Serial Data
12-14	-	-	Not Used
15	YE	234	Seat Belt Indicator Control
16	GY	728	Security Indicator Control
17-18	-	-	Not Used

DIAGNOSTIC INFORMATION AND PROCEDURES

DIAGNOSTIC CODE INDEX

DIAGNOSTIC CODE INDEX

DTC	Description
<u>DTC P0461</u>	Fuel Level Sensor Performance
<u>DTC P0462</u>	Fuel Level Sensor Circuit Low Voltage
<u>DTC P0463</u>	Fuel Level Sensor Circuit High Voltage
<u>DTC P0520</u>	Engine Oil Pressure (EOP) Sensor Circuit

DIAGNOSTIC STARTING POINT - DISPLAYS AND GAGES

Begin the displays and gages system diagnosis with **Diagnostic System Check - Vehicle** or the audible warning system diagnosis with **Diagnostic System Check - Vehicle** . The Diagnostic System Check will provide the following information:

- The identification of the control modules which command the system
- The ability of the control modules to communicate through the serial data circuit
- The identification of any stored diagnostic trouble codes (DTCs) and their status

2007 Hummer H3

2007 ACCESSORIES & EQUIPMENT Displays and Gages - H3

The use of the Diagnostic System Check will identify the correct procedure for diagnosing the system and where the procedure is located.

SCAN TOOL OUTPUT CONTROLS

Scan Tool Output Controls

Scan Tool Output Control	Additional Menu Selection(s)	Description
IPC Gages	-	The IPC drives all gages to the maximum physical position when you select On. The IPC drives all gages to the minimum physical position when you select Off.
Lamp Test	-	<p>The IPC illuminates the following indicators when you select On:</p> <ul style="list-style-type: none">• ABS• Air Bag• Brake• CRUISE• Fasten safety belt• High beam• SECURITY• Upshift <p>The indicators should illuminate until commanded Off.</p>
PRNDL Display	-	An underscore illuminates under each indicator in the PRNDL display until commanded Off.
Segments Test	-	All DIC and Odometer segments illuminate until commanded Off.

SCAN TOOL DATA LIST

The scan tool data lists contain all of the Instrument Panel, Gages and Console related parameters that are available on the scan tool. The parameters in the list are arranged in alphabetical order. The data list column indicates the location of the parameter within the scan tool menu selections.

2007 Hummer H3

2007 ACCESSORIES & EQUIPMENT Displays and Gages - H3

Use the scan tool data lists as directed by a diagnostic table or in order to supplement the diagnostic procedures. Begin all of the diagnostic procedures with **Diagnostic System Check - Vehicle** .

Use the scan tool data lists only after the following is determined:

- There is no published DTC procedure nor published symptom procedure for the customer concern.
- The DTC or symptom procedure indicated by the Diagnostic System Check does not resolve the customer concern.

The typical data values are obtained from a properly operating vehicle under the conditions specified in the first row of the scan tool data list table. Comparison of the parameter values from the suspect vehicle with the typical data values may reveal the source of the customer concern.

Body Control Module (BCM)

Scan Tool Parameter	Data List	Units Displayed	Typical Data Value
Operating Conditions: Ignition ON/Engine OFF/Headlamps Off/Doors Closed/Park Brake Unapplied			
Battery Voltage Signal	Data	Volts	12.2 V
Cargo Lamp Switch	Inputs	Active/Inactive	Inactive
Courtesy Lamp Output	Outputs	On/Off	Off
Courtesy Lamp Switch	Inputs	Active/Inactive	Inactive
Driver Door Ajar Sw	Inputs	Door Ajar/Door Closed	Door Closed
Driver Seatbelt	Inputs	Unbuckled/Buckled	Unbuckled
Hazard Lamp Switch	Inputs	Active/Inactive	Inactive
Headlamp Off Switch	Inputs	Active/Inactive	Inactive
Headlamp On Switch	Inputs	Active/Inactive	Inactive
Headlamp Relay	Outputs	On/Off	Off
High Beam Indicator Command	Outputs	On/Off	Off
High Beam Select Switch	Inputs	Active/Inactive	Inactive
Ignition Accessory	Inputs	Active/Inactive	Active
Ignition 1 Run/Crank	Inputs	Active/Inactive	Active
Ign. Off/Run/Crank	Inputs	Active/Inactive	Active
LF Turn/Hazard Lamp Command	Outputs	On/Off	Off

2007 Hummer H3

2007 ACCESSORIES & EQUIPMENT Displays and Gages - H3

LR Turn/Hazard Lamp Command	Outputs	On/Off	Off
Park Brake Switch	Inputs	Applied/Released	Released
Park Lamps Signal	Outputs	On/Off	Off
Park Lamp Switch	Inputs	On/Off	Off
Passenger Door Ajar Sw	Inputs	Door Ajar/Door Closed	Door Closed
RF Turn/Hazard Lamp Command	Outputs	On/Off	Off
RR Turn/Hazard Lamp Command	Outputs	On/Off	Off
Security Indicator Command	Outputs	On/Off	Off

Instrument Panel Cluster (IPC)

Scan Tool Parameter	Data List	Units Displayed	Typical Data Value
Operating Conditions: Ignition ON/Engine OFF/Seat Belt Buckled/High Beams Off/Park Brake Unapplied			
Battery Voltage	Data	Voltage	12.2 V (Varies)
Engine Coolant Temperature	Data	Celsius (Fahrenheit)	Varies
Engine Speed	Data	RPM	0 RPM
Fuel Level	Data	%	Varies
PRNDL Switch	Inputs	Park, Reverse, Neutral, Drive, 3rd, 2nd, 1st	Park
Trip Odometer	Data	kilometers (miles)	Varies
Trip Reset Switch	Inputs	Active/Inactive	Inactive
Vehicle Speed	Data	kilometers per hour (miles per hour)	0 mph (0 km/h)

Powertrain Control Module (PCM)

Scan Tool Parameter	Data List	Units Displayed	Typical Data Value
Operating Conditions: Engine Idling/Normal Operating Temperature			
Ambient Air Temperature	Engine Data	Celsius (Fahrenheit)	-35-60°C (-31-140°F) (Varies)
	Cruise Control		

2007 Hummer H3

2007 ACCESSORIES & EQUIPMENT Displays and Gages - H3

Cruise Control Active	Active IPC Data	Yes/No	No
ECT Sensor	Engine Data Air Data CMP Data EVAP Data Fuel Trim Data HO2S Data Ignition Data Misfire Data TAC Data Cooling/HVAC Data Cruise Control Data Electrical/Theft Data IPC Data I/M Data	Celsius (Fahrenheit)	85-105°C (185- 220°F)
Engine Oil Level Switch	Engine Data	OK/Low	OK
Engine Oil Pressure Switch	Engine Data CMP Data Electrical/Theft Data IPC Data	OK/Low	OK
Engine Oil Temperature Calculated	IPC Data	Celsius (Fahrenheit)	85-105°C (185- 220°F)
Engine Speed	Engine Data Air Data CMP Data EVAP Data Fuel Trim Data HO2S Data Ignition Data Induction Data Misfire Data TAC Data Cooling/HVAC Data	RPM	±100 RPM from desired idle speed

2007 Hummer H3

2007 ACCESSORIES & EQUIPMENT Displays and Gages - H3

	Cruise Control Data Electrical/Theft Data IPC Data		
Fuel Level Sensor	EVAP Data IPC Data	Voltage	0-5 V (Varies)
Fuel Tank Level Remaining	Engine Data EVAP Data Misfire Data IPC Data I/M Data	Percent	0-100% (Varies)
Ignition Accessory Signal	IPC Data	On/Off	On
Ignition 1 Signal	Engine Data Air Data CMP Data EVAP Data Fuel Trim Data HO2S Data Ignition Data Induction Data Misfire Data TAC Data Cooling/HVAC Data Cruise Control Data Electrical/Theft Data IPC Data I/M Data	Voltage	12.2 V (Varies)
Low EOP Indicator Command	IPC Data	On/Off	Off
MIL (Malfunction Indicator Lamp) Command	Engine Data IPC Data I/M Data	On/Off	Off
MIL Circuit Status	Engine Data IPC Data	OK/Short Gnd/Open/Short to B+/Incomplete	OK
	Engine Data		

2007 Hummer H3

2007 ACCESSORIES & EQUIPMENT Displays and Gages - H3

MIL Requested by DTC	Air Data CMP Data EVAP Data Fuel Trim Data HO2S Data Induction Data Misfire Data TAC Data Electrical/Theft Data I/M Data	Yes/No	No
Reduced Engine Power	TAC Data	Active/Inactive	Inactive
Vehicle Speed Sensor	Engine Data Air Data CMP Data EVAP Data Fuel Trim Data HO2S Data Ignition Data Induction Data Misfire Data TAC Data Cooling/HVAC Data Electrical/Theft Data IPC Data I/M Data	km/h (mph)	0 km/h (0 mph)

Radio

Scan Tool Parameter	Data List	Units Displayed	Typical Data Value
Operating Conditions: Ignition in RUN, Radio ON			
Balance	Data	Value	-50 to +50
Battery Voltage	Data	Volts	0-18 V
Fade	Data	Value	-50 to +50
Volume	Data	Percent	0-100%

SCAN TOOL DATA DEFINITIONS

Ambient Temperature Sensor

The scan tool displays 0-100°C. The measured temperature from the ambient outside air temperature sensor to the powertrain control module (PCM).

Balance

The scan tool displays 0-100%. The amount of left to right balance selected.

Battery Voltage

The scan tool displays 0-19 volts. The voltage measured at the battery positive voltage circuit of the instrument panel cluster (IPC).

Battery Voltage

The scan tool displays 0-19 volts. The battery voltage as monitored by the Radio.

Battery Voltage Signal

The scan tool displays 0-19 volts. The battery voltage as monitored by the body control module (BCM).

Cargo Lamp Switch

The scan tool displays Active or Inactive. The BCM monitors the signal circuit of the cargo lamp switch. A closed switch is displayed as Active.

Courtesy Lamp Output

The scan tool displays the commanded state of the courtesy lamp relay. The scan tool displays On when the BCM allows the courtesy lamp relay to go to ground to activate the courtesy lamps.

Courtesy Lamp Switch

The scan tool displays Active or Inactive. The BCM monitors the signal circuit of the courtesy lamp switch. A closed switch is displayed as Active.

Cruise Control Active

The scan tool displays Yes or No. The state of the cruise control indicator as commanded by

the powertrain control module (PCM).

Displayed Fuel Level

The scan tool displays 0-100%. The displayed fuel gage value in the IPC. This value may slightly differ from the monitored fuel level.

Driver Door Ajar Switch

The scan tool displays Door Ajar or Door Closed. The BCM monitors the signal circuit of the driver door ajar switch. An open switch is displayed as Door Ajar with the door open.

Driver Seatbelt

The scan tool displays Unbuckled or Buckled. The state of the fasten safety belt indicator as commanded by the BCM.

ECT Sensor

The scan tool displays -40 to +151°C (-40 to +304°F). The powertrain control module (PCM) monitors the voltage at the signal circuit of the engine coolant temperature sensor. The voltage is inversely proportional to the engine coolant temperature.

Engine Coolant Temperature

The scan tool displays 38°C-128°C (100°F-260°F). The displayed coolant temperature gage value in the IPC. This value may slightly differ from the monitored coolant temperature.

Engine Oil Level Switch

The scan tool displays OK or Low. The PCM monitors the signal circuit of the engine oil level and temperature sensor. A closed switch is displayed as Low with low engine oil level.

Engine Oil Pressure Switch

The scan tool displays OK or Low. The PCM monitors the signal circuit of the engine oil pressure switch. A closed switch is displayed as Low with low engine oil pressure.

Engine Oil Temperature Calculated

The scan tool displays Celsius (Fahrenheit). This is a calculated value of the engine oil as determined by the PCM.

Engine Speed

The scan tool displays 0-9999 RPM. The IPC monitors the engine speed signal circuit from the PCM.

Engine Speed

The scan tool displays 0-9999 RPM. The PCM computes the engine speed. It should remain close to desired idle under various engine loads with the engine idling.

Fade

The scan tool displays 0-252 counts. The amount of front to rear fade selected.

Fuel Level

The scan tool displays 0-100%. The IPC calculates the amount of fuel remaining in the tank based on the input from the PCM.

Fuel Level Sensor

The scan tool displays 0-5 volts. The PCM calculates the amount of fuel remaining in the tank based on the input from the fuel level sensor.

Fuel Level Sensor

The scan tool displays 0-100%. The PCM calculates the amount of fuel remaining in the tank based on the input from the fuel level sensor.

Hazard Lamp Switch

The scan tool displays Active or Inactive. The BCM monitors the hazard lamp switch circuit. When the hazard switch is turned Off the signal is displayed as Inactive.

Headlamp Off Switch

The scan tool displays Active or Inactive. The BCM monitors the signal circuit of the headlamp Off switch. A closed switch is displayed as Active.

Headlamp On Switch

The scan tool displays Active or Inactive. The BCM monitors the signal circuit of the

headlamp on switch. A closed switch is displayed as On.

Headlamp Relay

The scan tool displays On or Off. This is the state of the headlamp and the panel dimmer switch. The scan tool displays On when the headlamp and the panel dimmer switch is turned On or in auto position with the ambient light sensor in its dark state.

High Beam Indicator Command

The scan tool displays On or Off. This is the state of the high beam indicator as commanded by the IPC.

High Beam Select Switch

The scan tool displays Active or Inactive. The BCM monitors the high beam select switch circuit. When the high beam select switch is turned On the signal is displayed as Active.

Ignition 1 Signal

The scan tool displays 0-19 volts. The voltage measured at the ignition 1 voltage circuit of the PCM.

Ignition Accessory Signal

The scan tool displays On or Off. The BCM monitors the position of the ignition switch. On is displayed when the ignition switch is in the Run or ACCY position.

Ignition Off/Run/Crank

The scan tool displays Active or Inactive. The BCM monitors the signal circuit of the key in ignition switch. A closed switch is displayed as Active with the key in the ignition.

Ignition 1 Run/Crank

The scan tool displays Active or Inactive. The BCM monitors the position of the ignition switch. Active is displayed when the ignition switch is in the Run or CRANK position.

LF Turn/Hazard Lamp Command

The scan tool displays On or Off. This is the state of the left front turn lamp as commanded by the BCM.

LR Turn/Hazard Lamp Command

The scan tool displays On or Off. This is the state of the left rear turn lamp as commanded by the BCM.

Low EOP Indicator Command

The scan tool displays On or Off. This is the commanded state of the low engine oil pressure indicator by the PCM.

MIL (Malfunction Indicator Lamp) Command

The scan tool displays On or Off. This is the commanded state of the malfunction indicator lamp (MIL) by the PCM.

MIL Circuit Status

The scan tool displays OK, Short Gnd/Open, Short to B+ or Incomplete. This is the state of the MIL signal circuit as monitored by the PCM.

MIL Requested by DTC

The scan tool displays Yes or No. This is the parameter for determining if the MIL lamp is commanded on due to a set PCM DTC.

Park Brake Switch

The scan tool displays Applied or Released. The BCM monitors the signal circuit of the park brake switch. A closed switch is displayed as Applied.

Park Lamp Switch

The scan tool displays Active or Inactive. The BCM monitors the signal circuit of the parklamp switch. A closed switch is displayed as Active.

Passenger Door Ajar Switch

The scan tool displays Door Ajar or Door Closed. The BCM monitors the signal circuit of the passenger door ajar switch. An open switch is displayed as Door Ajar with the door open.

PRNDL Switch

The scan tool displays Park, Reverse, Neutral, Drive, 1st, 2nd or 3rd. The state of the PRNDL as commanded by the IPC.

Reduced Engine Power

The scan tool displays Inactive or Active. This is the state of the Reduced Engine Power indicator as monitored by the PCM.

RF Turn/Hazard Lamp Command

The scan tool displays On or Off. This is the state of the right front turn lamp as commanded by the BCM.

RR Turn/Hazard Lamp Command

The scan tool displays On or Off. This is the state of the right rear turn lamp as commanded by the BCM.

Security Indicator Command

The scan tool displays On or Off. This is the state of the security indicator as commanded by the BCM.

Trip Odometer

The scan tool displays miles. The IPC calculates trip odometer information from the vehicle speed data received from the PCM.

Trip Reset Switch

The scan tool displays Active or Inactive. The IPC monitors the control stem on the cluster. A closed switch is displayed as Active.

Vehicle Speed

The scan tool displays 0-255 km/h (0-155 mph). The IPC monitors the vehicle speed signal circuit from the PCM.

Vehicle Speed Sensor

The scan tool displays 0-255 km/h (0-155 mph). The PCM monitors the voltage at the signal circuit of the vehicle speed sensor. The voltage is proportional to the vehicle speed.

2007 Hummer H3

2007 ACCESSORIES & EQUIPMENT Displays and Gages - H3

Volume

The scan tool displays 0-100%. The volume selected.

DTC P0461

Diagnostic Instructions

- Perform the **Diagnostic System Check - Vehicle** prior to using this diagnostic procedure.
- Review **Strategy Based Diagnosis** for an overview of the diagnostic approach.
- **Diagnostic Procedure Instructions** provides an overview of each diagnostic category.

DTC Descriptor

DTC P0461

Fuel Level Sensor Performance

Diagnostic Fault Information

DTC P0461

Circuit	Short to Ground	Open/High Resistance	Short to Voltage	Signal Performance
Fuel Level Sensor Reference Voltage Circuit	P0462	-	-	P0461
Fuel Level Sensor Signal Circuit	P0462	P0463 1	P0463	P0461
Fuel Level Sensor Low Reference Circuit	-	P0463 1	P0463	P0461

1. Fuel Gage Inaccurate or Inoperative

Circuit Description

The fuel level sender changes resistance based on fuel level. The powertrain control module (PCM) monitors the signal circuit of the fuel level sender in order to determine fuel level. When the fuel tank is full, the sender resistance is low and the PCM senses a low signal voltage. When the fuel tank is empty, the sender resistance is high and the PCM senses a high signal voltage. The PCM uses the signal circuit of the fuel level sender in order to calculate the total remaining fuel percent in the tank. The PCM sends the fuel level percent via the class 2 serial data circuit to the instrument cluster in order to control the fuel gage. The fuel level information is also used for misfire and evaporative emission (EVAP) diagnostics.

This diagnostic tests for a stuck fuel level sender signal. The PCM sets this DTC if the fuel level sender signal appears to be stuck based on a lack of signal variation expected during normal operation.

Conditions for Running the DTC

- The ignition is ON.
- The PCM has confirmed that the fuel tank is between 15-85 percent full.

Conditions for Setting the DTC

The PCM does not detect a change in fuel level of at least 3.0L (0.79 gal) over a distance of 320 km (200 mi).

Action Taken When the DTC Sets

- The fuel gage defaults to empty.
- The LOW FUEL indicator illuminates.
- The PCM records the operating conditions at the time the diagnostic fails. The PCM stores the failure information in the Failure Records on the scan tool.

Conditions for Clearing the DTC

- The DTC becomes history when the conditions for setting the DTC are no longer present.
- The history DTC clears after 40 malfunction-free warm-up cycles.
- The PCM receives the clear code command from the scan tool.

Reference Information**Fuel Level Specifications****Fuel Level Specifications****Schematic Reference**

- **Instrument Cluster Schematics**
- **Engine Controls Schematics**

Connector End View Reference

- **Displays and Gages Connector End Views**

- **Powertrain Control Module Connector End Views**

Electrical Information Reference

- **Circuit Testing**
- **Connector Repairs**
- **Testing for Intermittent Conditions and Poor Connections**
- **Wiring Repairs**

Scan Tool Reference

Scan Tool Data List

Circuit/System Testing

1. Ignition OFF, remove the fuel level sender and verify that there is no obstructions interfering with the fuel level sender.
 - If interference is present, remove the obstruction.
2. If no interference is present, replace the fuel level sender.

Repair Procedures

Perform the **Diagnostic Repair Verification** after completing the diagnostic procedure.

- **Fuel Level Sensor Replacement**
- **Control Module References** for the PCM replacement, setup and programming

DTC P0462

Diagnostic Instructions

- Perform the **Diagnostic System Check - Vehicle** prior to using this diagnostic procedure.
- Review **Strategy Based Diagnosis** for an overview of the diagnostic approach.
- **Diagnostic Procedure Instructions** provides an overview of each diagnostic category.

DTC Descriptor

DTC P0462

Fuel Level Sensor Circuit Low Voltage

2007 Hummer H3

2007 ACCESSORIES & EQUIPMENT Displays and Gages - H3

Diagnostic Fault Information

DTC P0462

Circuit	Short to Ground	Open/High Resistance	Short to Voltage	Signal Performance
Fuel Level Sensor Reference Voltage Circuit	P0462	-	-	P0461
Fuel Level Sensor Signal Circuit	P0462	P0463 1	P0463	P0461
Fuel Level Sensor Low Reference Circuit	-	P0463 1	P0463	P0461
1. Fuel Gage Inaccurate or Inoperative				

Circuit Description

The fuel level sender changes resistance based on fuel level. The powertrain control module (PCM) monitors the signal circuit of the fuel level sender in order to determine fuel level. When the fuel tank is full, the sender resistance is low and the PCM senses a low signal voltage. When the fuel tank is empty, the sender resistance is high and the PCM senses a high signal voltage. The PCM uses the signal circuit of the fuel level sender in order to calculate the total remaining fuel percentage in the tank. The PCM sends the fuel level percent via the class 2 serial data circuit to the instrument cluster in order to control the fuel gage. The fuel level information is also used for misfire and evaporative emission (EVAP) diagnostics.

Conditions for Running the DTC

The ignition is ON.

Conditions for Setting the DTC

- The fuel level signal is greater than 99 percent.
- The above condition is present for greater than 20 seconds.

Action Taken When the DTC Sets

- The fuel gage defaults to empty.
- The LOW FUEL indicator illuminates.
- The PCM records the operating conditions at the time the diagnostic fails. The PCM displays the failure information in the Failure Records on the scan tool.

Conditions for Clearing the DTC

- The DTC becomes history when the conditions for setting the DTC are no longer present.
- The history DTC clears after 40 malfunction-free warm-up cycles.
- The PCM receives the clear code command from the scan tool.

Reference Information

Fuel Level Specifications

Fuel Level Specifications

Schematic Reference

- Instrument Cluster Schematics
- Engine Controls Schematics

Connector End View Reference

- Displays and Gages Connector End Views
- Powertrain Control Module Connector End Views

Electrical Information Reference

- Circuit Testing
- Connector Repairs
- Testing for Intermittent Conditions and Poor Connections
- Wiring Repairs

Scan Tool Reference

Scan Tool Data List

Circuit/System Testing

1. Ignition OFF, disconnect the harness connector at the fuel level sensor.
2. Ignition ON, verify that the scan tool Fuel Tank Level Remaining parameter is less than 4 percent.
 - If greater than 4 percent, test the signal circuit for a short to ground. If the circuit tests normal, replace the PCM.
3. If all circuits test normal, test or replace the fuel level sensor.

2007 Hummer H3

2007 ACCESSORIES & EQUIPMENT Displays and Gages - H3

Repair Procedures

Perform the **Diagnostic Repair Verification** after completing the diagnostic procedure.

- **Fuel Level Sensor Replacement**
- **Control Module References** for the PCM replacement, setup and programming

DTC P0463

Diagnostic Instructions

- Perform the **Diagnostic System Check - Vehicle** prior to using this diagnostic procedure.
- Review **Strategy Based Diagnosis** for an overview of the diagnostic approach.
- **Diagnostic Procedure Instructions** provides an overview of each diagnostic category.

DTC Descriptor

DTC P0463

Fuel Level Sensor Circuit High Voltage

Diagnostic Fault Information

DTC P0463

Circuit	Short to Ground	Open/High Resistance	Short to Voltage	Signal Performance
Fuel Level Sensor Reference Voltage Circuit	P0462	-	-	P0461
Fuel Level Sensor Signal Circuit	P0462	P0463 1	P0463	P0461
Fuel Level Sensor Low Reference Circuit	-	P0463 1	P0463	P0461

1. Fuel Gage Inaccurate or Inoperative

Circuit Description

The fuel level sender changes resistance based on fuel level. The powertrain control module (PCM) monitors the signal circuit of the fuel level sender in order to determine fuel level. When the fuel tank is full, the sender resistance is low and the PCM senses a low signal voltage. When the fuel tank is empty, the sender resistance is high and the PCM senses a high signal voltage. The PCM uses the signal circuit of the fuel level sender in order to calculate the total remaining fuel

percentage in the tank. The PCM sends the fuel level percent via the class 2 serial data circuit to the instrument cluster in order to control the fuel gage. The fuel level information is also used for misfire and evaporative emission (EVAP) diagnostics.

Conditions for Running the DTC

The ignition is ON.

Conditions for Setting the DTC

- The fuel level signal is less than 1 percent.
- The above condition is present for greater than 20 seconds.

Action Taken When the DTC Sets

- The fuel gage defaults to empty.
- The LOW FUEL indicator illuminates.
- The PCM records the operating conditions at the time the diagnostic fails. The PCM displays the failure information in the Failure Records on the scan tool.

Conditions for Clearing the DTC

- The DTC becomes history when the conditions for setting the DTC are no longer present.
- The history DTC clears after 40 malfunction-free warm-up cycles.
- The PCM receives the clear code command from the scan tool.

Reference Information**Fuel Level Specifications****Fuel Level Specifications****Schematic Reference**

- **Instrument Cluster Schematics**
- **Engine Controls Schematics**

Connector End View Reference

- **Displays and Gages Connector End Views**
- **Powertrain Control Module Connector End Views**

Electrical Information Reference

- **Circuit Testing**
- **Connector Repairs**
- **Testing for Intermittent Conditions and Poor Connections**
- **Wiring Repairs**

Scan Tool Reference

Scan Tool Data List

Circuit/System Testing

1. Ignition OFF, disconnect the harness connector at the fuel level sensor.
2. Ignition OFF, test for less than 1 ohm of resistance between the low reference circuit and ground.
 - If greater than 1 ohm, test the low reference circuit for a short to voltage or an open/high resistance. If the circuit tests normal, replace the PCM.
3. Ignition ON, install a 3-amp fused jumper between the signal circuit and the low reference circuit. Verify the scan tool Fuel Tank Level Remaining parameter or the Fuel Level Sensor parameter is greater than 98 percent.
 - If less than 98 percent, test the signal circuit for a short to voltage or an open/high resistance. If the circuit tests normal, replace the PCM.
4. If all circuits test normal, test or replace the fuel level sensor.

Repair Procedures

Perform the **Diagnostic Repair Verification** after completing the diagnostic procedure.

- **Fuel Level Sensor Replacement**
- **Control Module References** for the PCM replacement, setup and programming

DTC P0464

Diagnostic Instructions

- Perform the **Diagnostic System Check - Vehicle** prior to using this diagnostic procedure.
- Review **Strategy Based Diagnosis** for an overview of the diagnostic approach.
- **Diagnostic Procedure Instructions** provides an overview of each diagnostic category.

2007 Hummer H3

2007 ACCESSORIES & EQUIPMENT Displays and Gages - H3

DTC Descriptor

DTC P0464

Fuel Level Sensor Circuit High Voltage

Diagnostic Fault Information

DTC P0464

Circuit	Short to Ground	Open/High Resistance	Short to Voltage	Signal Performance
Fuel Level Sensor Signal Circuit	P0462	P0463, P0464 1	P0463	P0461
Fuel Level Sensor Low Reference Circuit	-	P0463, P0464 1	P0463	P0461
1. Fuel Gage Inaccurate or Inoperative				

Circuit Description

The fuel level sender changes resistance based on fuel level. The powertrain control module (PCM) monitors the signal circuit of the fuel level sender in order to determine fuel level. When the fuel tank is full, the sender resistance is low and the PCM senses a low signal voltage. When the fuel tank is empty, the sender resistance is high and the PCM senses a high signal voltage. The PCM uses the signal circuit of the fuel level sender in order to calculate the total remaining fuel percentage in the tank. The PCM sends the fuel level percent via the class 2 serial data circuit to the instrument cluster in order to control the fuel gage. The fuel level information is also used for misfire and evaporative emission (EVAP) diagnostics.

Conditions for Setting the DTC

- The fuel level change is greater than 10 percent.
- The above condition is present for greater than 30 seconds.

Action Taken When the DTC Sets

- DTC P0442 is aborted.
- The ECM/PCM records the operating conditions at the time the diagnostic fails. The ECM/PCM displays the failure information in the Failure Records on the scan tool.

Conditions for Clearing the DTC

- The DTC becomes history when the conditions for setting the DTC are no longer present.
- The history DTC clears after 40 malfunction-free warm-up cycles.

Reference Information

Fuel Level Specifications

Fuel Level Specifications

Schematic Reference

- Instrument Cluster Schematics
- Engine Controls Schematics

Connector End View Reference

- Displays and Gages Connector End Views
- Powertrain Control Module Connector End Views

Electrical Information Reference

- Circuit Testing
- Connector Repairs
- Testing for Intermittent Conditions and Poor Connections
- Wiring Repairs

Scan Tool Reference

Scan Tool Data List

Circuit/System Testing

1. Ignition OFF, disconnect the harness connector at the fuel level sensor.
2. Ignition OFF, test for less than 1 ohm of resistance between the low reference circuit and ground.
 - If greater than 1 ohm, test the low reference circuit for a short to voltage or an open/high resistance. If the circuit tests normal, replace the PCM.
3. Install a Signal Generator and Instrument Panel Tester between the signal circuit terminal 2 and the low reference circuit terminal 3.

2007 Hummer H3

2007 ACCESSORIES & EQUIPMENT Displays and Gages - H3

4. Ignition ON, vary the signal generator resistance between 40 and 250 ohms. Verify that the scan tool Fuel Tank Level Remaining or the Fuel Level Sensor parameter displays a range that varies between 5 and 95 percent as the signal generator resistance changes.
 - If not within the specified range, test the signal circuit for an open/high resistance. If the circuit tests normal, replace the PCM.
5. If all circuits test normal, test or replace the fuel level sensor.

Repair Procedures

Perform the **Diagnostic Repair Verification** after completing the diagnostic procedure.

- **Fuel Level Sensor Replacement**
- **Control Module References** for the PCM replacement, setup and programming

DTC P0520

Diagnostic Instructions

- Perform the **Diagnostic System Check - Vehicle** prior to using this diagnostic procedure.
- Review **Strategy Based Diagnosis** for an overview of the diagnostic approach.
- **Diagnostic Procedure Instructions** provides an overview of each diagnostic category.

DTC Descriptor

DTC P0520

Engine Oil Pressure (EOP) Sensor Circuit

Diagnostic Fault Information

DTC P0520

Circuit	Short to Ground	Open/High Resistance	Short to Voltage	Signal Performance
Oil Pressure Switch Signal	1	P0520	-	-
Low Reference Oil Pressure Switch Signal	-	P0520	-	-

1. Engine Oil Pressure Indicator Always On

Circuit Description

With low oil pressure, the engine oil pressure (EOP) switch closes and the signal circuit is low.

With oil pressure above 4.5 psi, the EOP switch opens and the signal circuit is high. The powertrain control module (PCM) monitors the oil pressure switch signal circuit and sends a class 2 message to the instrument panel cluster (IPC), indicating the switch status.

Conditions for Running the DTC

- DTC P0117 is not set.
- DTC P0118 is not set.
- DTC P1111 is not set.
- DTC P1114 is not set.
- The ignition is ON, with the engine OFF.
- Engine temperature at the last shutdown was at least 80°C (176°F).

Conditions for Setting the DTC

- The PCM detects that the oil pressure switch signal circuit is high.
- The above condition is present for greater than 10 seconds.

Action Taken When the DTC Sets

The PCM stores the conditions that are present when the DTC sets. This information is stored as Failure Records data only. This information is not stored as Freeze Frame data.

Conditions for Clearing the DTC

- The DTC becomes history when the conditions for setting the DTC are no longer present.
- The history DTC clears after 40 malfunction-free warm-up cycles.
- The PCM receives the clear code command from the scan tool.

Reference Information**Schematic Reference**

- **Instrument Cluster Schematics**
- **Engine Controls Schematics**

Connector End View Reference

- **Displays and Gages Connector End Views**
- **Powertrain Control Module Connector End Views**

Electrical Information Reference

- **Circuit Testing**
- **Connector Repairs**
- **Testing for Intermittent Conditions and Poor Connections**
- **Wiring Repairs**

Scan Tool Reference

Scan Tool Data List

Circuit/System Testing

1. Ignition OFF, disconnect the EOP switch.
2. Ignition OFF, test for less than 1 ohm of resistance between the low reference circuit and ground.
 - If greater than 1 ohm, test the low reference circuit for an open/high resistance. If the circuit tests normal, replace the PCM.
3. Ignition ON, install a 3-amp fused jumper wire between the signal circuit and the low reference circuit. Verify the scan tool Engine Oil Pressure Switch parameter is Low.
 - If not Low, test the signal circuit of the EOP switch for an open/high resistance. If the circuit tests normal replace the PCM.
4. If all circuits test normal, test or replace the EOP switch.

Repair Procedures

Perform the **Diagnostic Repair Verification** after completing the diagnostic procedure.

- **Engine Oil Pressure Sensor and/or Switch Replacement**
- **Control Module References** for the PCM replacement, setup and programming

SYMPTOMS - DISPLAYS AND GAGES

IMPORTANT: The following steps must be completed before using the symptom tables.

1. Perform the **Diagnostic System Check - Vehicle** before using the Symptom Tables in order to verify that all of the following are true:
 - There are no DTCs set.

- The control modules can communicate via the serial data link.
2. Review the system operation in order to familiarize yourself with the system functions. Refer to the following:

- **Instrument Cluster Description and Operation**
- **Indicator/Warning Message Description and Operation**
- **Driver Information Center (DIC) Description and Operation**
- **Audible Warnings Description and Operation**
- **Door Ajar Indicator Description and Operation**
- **Compass Calibration and Magnetic Variance**

Visual/Physical Inspection

- Inspect for aftermarket devices which could affect the operation of the Instrument Cluster or Audible Warning Systems. Refer to **Checking Aftermarket Accessories** .
- Inspect the easily accessible or visible system components for obvious damage or conditions which could cause the symptom.
- Inspect the applicable reservoir for the proper fluid level related to the indicator or message.
- Verify that the indicators work properly during the displays test.

Intermittent

Faulty electrical connections or wiring may be the cause of intermittent conditions. Refer to **Testing for Intermittent Conditions and Poor Connections** .

Symptom List

Refer to a symptom diagnostic procedure from the following list in order to diagnose the symptom:

Gages

- **Engine Coolant Temperature Gage Inaccurate or Inoperative**
- **Fuel Gage Inaccurate or Inoperative**
- **Speedometer and/or Odometer Inaccurate or Inoperative**
- **Tachometer Inaccurate or Inoperative**

Indicators

- **ABS Indicator Always On**
- **ABS Indicator Inoperative**
- **Air Bag Indicator Circuit Malfunction**
- **Brake Warning Indicator Malfunction**
- **Charge Indicator Always On**
- **Charge Indicator Inoperative**
- **Door Ajar Indicator Malfunction**
- **Engine Oil Pressure Indicator Always On**
- **Engine Overheated Indicator Always On**
- **Fog Lamp Indicator Inoperative**
- **High Beam Indicator Always On**
- **High Beam Indicator Inoperative**
- **Malfunction Indicator Lamp (MIL) Always On** for the 3.7L engine
- **Malfunction Indicator Lamp (MIL) Inoperative** for the 3.7L engine
- **Mirror Compass Display Inoperative or Inaccurate**
- **Mirrors - Temperature Display Inaccurate**
- **Mirrors - Temperature Displays SC or OC**
- **Passenger Presence System Indicator Circuit Malfunction**
- **Security Indicator Malfunction**
- **Seat Belt Indicator Circuit Malfunction - Driver**
- **Seat Belt Indicator Circuit Malfunction - Passenger**
- **Service Indicator Always On**
- **Service Indicator Inoperative**
- **Traction Off Indicator Inoperative**
- **Transfer Case Shift Control Switch Indicator Always On - Two or More**
- **Transfer Case Shift Control Switch Indicator Flashes, then Returns to Previous Mode**
- **Transfer Case Shift Control Switch Indicator Inoperative - One or More**
- **Turn Signal Lamps and/or Indicators Always On or Flashing**
- **Turn Signal Lamps and/or Indicators Inoperative**

- **Interior Backlighting Does Not Dim**
- **Interior Backlighting Inoperative**

Odometer

Odometer Trip/Reset Switch Inoperative

Audible Warning

- **Chime Always On**
- **Chime Inoperative**

CHIME ALWAYS ON

Diagnostic Instructions

- Perform the **Diagnostic System Check - Vehicle** prior to using this diagnostic procedure.
- Review **Strategy Based Diagnosis** for an overview of the diagnostic approach.
- **Diagnostic Procedure Instructions** provides an overview of each diagnostic category.

Circuit/System Description

The radio generates the audible warning through the left front speaker. The radio receives audible warning requests via GMLAN serial data from the body control module (BCM).

Reference Information

Schematic Reference

- **Instrument Cluster Schematics**
- **Body Control System Schematics**

Connector End View Reference

- **Displays and Gages Connector End Views**
- **Data Communication Connector End Views**

Electrical Information Reference

- **Circuit Testing**
- **Connector Repairs**

- **Testing for Intermittent Conditions and Poor Connections**
- **Wiring Repairs**

Scan Tool Reference

Scan Tool Data List

Circuit/System Testing

1. Ignition ON, headlamp switch OFF, verify the scan tool Headlamp Switch ON parameter is Inactive.
 - If not Inactive, test the headlamps signal circuit for an open or short to voltage. If the circuit tests normal, replace the headlamp switch.
2. Ignition ON, park lamp switch OFF, verify the scan tool Park Lamp Switch parameter is Off.
 - If not Off, test the park lamp switch signal circuit for an open or short to voltage. If the circuit tests normal, replace the headlamp switch.
3. Ignition OFF, key out of the ignition, verify the scan tool Ign. Off/Run/Crank parameter is Inactive.
 - If not Inactive, test the key in ignition signal circuit for a short to ground. If the circuit tests normal, replace the ignition switch.
4. Ignition ON, doors closed, verify the scan tool Door Ajar Switch parameters show Door Closed.
 - If not Door Closed, go to **Courtesy Lamps Always On** .
5. If all circuits test normal, replace the BCM.

Repair Procedures

Perform the **Diagnostic Repair Verification** after completing the diagnostic procedure.

- **Ignition and Start Switch Replacement**
- **Headlamp Switch Replacement**
- **Control Module References** for BCM replacement, setup and programming

CHIME INOPERATIVE

Diagnostic Instructions

- Perform the **Diagnostic System Check - Vehicle** prior to using this diagnostic procedure.

- Review **Strategy Based Diagnosis** for an overview of the diagnostic approach.
- **Diagnostic Procedure Instructions** provides an overview of each diagnostic category.

Circuit/System Description

The radio generates the audible warning through the left front speaker. The radio receives audible warning requests via class 2 serial data from the body control module (BCM).

Reference Information

Schematic Reference

- **Instrument Cluster Schematics**
- **Radio/Navigation System Schematics**

Connector End View Reference

- **Displays and Gages Connector End Views**
- **Entertainment/Communication Connector End Views**

Electrical Information Reference

- **Circuit Testing**
- **Connector Repairs**
- **Testing for Intermittent Conditions and Poor Connections**
- **Wiring Repairs**

Scan Tool Reference

Scan Tool Data List

Circuit/System Testing

1. Ignition OFF, key in the ignition, open the driver door. The courtesy lamps should illuminate
 - If the courtesy lamps do not illuminate, go to **Courtesy Lamps Inoperative** .
2. Ignition ON, radio ON, adjust the radio balance and fade to the left front speaker.
 - If the speaker does not operate properly, go to **Speakers Inoperative - One or More** .

3. If the speaker operates properly, replace the radio.

Repair Procedures

Perform the **Diagnostic Repair Verification** after completing the diagnostic procedure.

Control Module References for the Radio replacement, setup and programming

DOOR AJAR INDICATOR MALFUNCTION**Diagnostic Instructions**

- Perform the **Diagnostic System Check - Vehicle** prior to using this diagnostic procedure.
- Review **Strategy Based Diagnosis** for an overview of the diagnostic approach.
- **Diagnostic Procedure Instructions** provides an overview of each diagnostic category.

Circuit/System Description

The body control module (BCM) receives an input from all four door ajar switches, drivers, passengers, left rear and right rear. The door ajar switches are normally open when the doors are fully closed. When a door is opened, the door ajar switch contacts close providing a path to ground. The driver information center (DIC) on the instrument panel cluster (IPC), illuminates the door ajar message when the one of the doors is open. The IPC receives a serial data message from the BCM, indicating the door ajar status. If this message is displayed and the vehicle speed is greater than 8.1 km/h (5 mph), a chime will sound.

Reference Information**Schematic Reference**

- **Instrument Cluster Schematics**
- **Door Lock/Indicator Schematics**

Connector End View Reference

- **Displays and Gages Connector End Views**
- **Vehicle Access Connector End Views**

Electrical Information Reference

- **Circuit Testing**

- **Connector Repairs**
- **Testing for Intermittent Conditions and Poor Connections**
- **Wiring Repairs**

Scan Tool Reference

Scan Tool Data List

Circuit/System Testing

1. Ignition OFF, disconnect the harness connectors at the four door ajar switch assemblies.
2. Ignition OFF, test for less than 1.0 ohm of resistance between each of the four ground circuits and ground.
 - If any of the ground circuits are greater than 1.0 ohm, test that ground circuit for an open/high resistance.
3. Verify all the scan tool Door Ajar Switch parameters show Door Closed.
 - If not Door Closed, test the appropriate signal circuit for a short to ground. If the circuits test normal, replace the BCM.
4. Install a 3-amp fused jumper one at a time between the four signal circuits and ground. Verify that each scan tool Door Ajar Switch parameter is Door Ajar when each signal circuit is jumpered.
 - If not Door Ajar, test the appropriate signal circuit for a short to voltage or an open/high resistance. If all circuits test normal, replace the BCM.
5. Ignition OFF, reconnect the harness connectors at the four door ajar switch assemblies, one at a time. Open and close the door with the reconnected harness. Verify that each scan tool Door Ajar Switch parameter is Door Ajar when the door is open and Door Closed when the door is closed.
 - If not Door Ajar when open or Door Closed when closed, replace the appropriate door ajar switch assembly.
6. If all circuits test normal, test or replace the IPC.

Repair Procedures

Perform the **Diagnostic Repair Verification** after completing the diagnostic procedure.

Control Module References for BCM or IPC replacement, setup and programming

ENGINE COOLANT TEMPERATURE GAGE INACCURATE OR INOPERATIVE

Diagnostic Instructions

- Perform the **Diagnostic System Check - Vehicle** prior to using this diagnostic procedure.
- Review **Strategy Based Diagnosis** for an overview of the diagnostic approach.
- **Diagnostic Procedure Instructions** provides an overview of each diagnostic category.

Circuit/System Description

The instrument panel cluster (IPC) displays the engine coolant temperature as determined by the powertrain control module (PCM). The IPC receives a serial data message from the PCM indicating the engine coolant temperature.

Reference Information

Schematic Reference

Instrument Cluster Schematics

Connector End View Reference

Displays and Gages Connector End Views

Electrical Information Reference

- **Circuit Testing**
- **Connector Repairs**
- **Testing for Intermittent Conditions and Poor Connections**
- **Wiring Repairs**

Scan Tool Reference

Scan Tool Data List

Circuit/System Testing

Ignition ON, perform the engine coolant gage sweep test with the scan tool.

- If the engine coolant gage does not sweep from its low to high position, replace the IPC.

Repair Procedures

Perform the **Diagnostic Repair Verification** after completing the diagnostic procedure.

Control Module References for the IPC replacement, setup and programming

ENGINE OIL PRESSURE INDICATOR ALWAYS ON

Diagnostic Instructions

- Perform the **Diagnostic System Check - Vehicle** prior to using this diagnostic procedure.
- Review **Strategy Based Diagnosis** for an overview of the diagnostic approach.
- **Diagnostic Procedure Instructions** provides an overview of each diagnostic category.

Circuit Description

With low oil pressure, the engine oil pressure (EOP) switch closes and the signal circuit is low. With oil pressure above 4.5 psi, the EOP switch opens and the signal circuit is high. The powertrain control module (PCM) monitors the oil pressure switch signal circuit and sends a class 2 message to the instrument panel cluster (IPC), indicating the switch status.

Reference Information

Schematic Reference

- **Instrument Cluster Schematics**
- **Engine Controls Schematics**

Connector End View Reference

- **Displays and Gages Connector End Views**
- **Powertrain Control Module Connector End Views**

Electrical Information Reference

- **Circuit Testing**
- **Connector Repairs**
- **Testing for Intermittent Conditions and Poor Connections**
- **Wiring Repairs**

Scan Tool Reference

Scan Tool Data List

Circuit/System Testing

1. Ignition OFF, disconnect the EOP switch.
2. Ignition ON, verify the scan tool Engine Oil Pressure Switch parameter is OK.
 - If not OK, test the signal circuit of the EOP switch for a short to ground. If the circuit tests normal replace the PCM.
3. Ignition ON, perform the lamp test with the scan tool to turn the engine oil pressure indicator OFF.
 - If the engine oil pressure indicator does not turn OFF, replace the IPC.
4. If all circuits test normal, test or replace the EOP switch.

Repair Procedures

Perform the **Diagnostic Repair Verification** after completing the diagnostic procedure.

- **Engine Oil Pressure Sensor and/or Switch Replacement**
- **Control Module References** for the PCM replacement, setup and programming

FUEL GAGE INACCURATE OR INOPERATIVE**Diagnostic Instructions**

- Perform the **Diagnostic System Check - Vehicle** prior to using this diagnostic procedure.
- Review **Strategy Based Diagnosis** for an overview of the diagnostic approach.
- **Diagnostic Procedure Instructions** provides an overview of each diagnostic category.

Circuit Description

The fuel level sender changes resistance based on fuel level. The powertrain control module (PCM) monitors the signal circuit of the fuel level sender in order to determine fuel level. When the fuel tank is full, the sender resistance is low and the PCM senses a low signal voltage. When the fuel tank is empty, the sender resistance is high and the PCM senses a high signal voltage. The PCM uses the signal circuit of the fuel level sender in order to calculate the total remaining fuel percentage in the tank. The PCM sends the fuel level percent via the class 2 serial data circuit to the instrument cluster in order to control the fuel gage. The fuel level information is also used for misfire and evaporative emission (EVAP) diagnostics.

Reference Information**Schematic Reference**

- **Instrument Cluster Schematics**

- **Engine Controls Schematics**

Connector End View Reference

- **Displays and Gages Connector End Views**
- **Powertrain Control Module Connector End Views**

Electrical Information Reference

- **Circuit Testing**
- **Connector Repairs**
- **Testing for Intermittent Conditions and Poor Connections**
- **Wiring Repairs**

Scan Tool Reference

Scan Tool Data List

Circuit/System Testing

1. Ignition OFF, disconnect the harness connector at the fuel level sensor. Install a signal generator and instrument panel tester between the signal circuit and the low reference circuit.
2. Ignition ON, vary the resistance on the signal generator from 40-250 ohms. Verify that the scan tool Fuel Tank Level Remaining parameter displays the correct fuel level percent.
 - If the fuel level percent is incorrect, test the signal circuit and the low reference circuit for an open/high resistance. If the circuits test normal, replace the PCM.
3. Ignition ON, vary the resistance on the signal generator from 40-250 ohms and monitor the fuel gage.
 - If the gage is incorrect, replace the IPC.
4. If all circuits test normal, test or replace the fuel level sensor.

Repair Procedures

Perform the **Diagnostic Repair Verification** after completing the diagnostic procedure.

- **Fuel Level Sensor Replacement**
- **Control Module References** for the PCM replacement, setup and programming

MIRROR COMPASS DISPLAY INOPERATIVE OR INACCURATE**Diagnostic Instructions**

- Perform the **Diagnostic System Check - Vehicle** prior to using this diagnostic procedure.
- Review **Strategy Based Diagnosis** for an overview of the diagnostic approach.
- **Diagnostic Procedure Instructions** provides an overview of each diagnostic category.

Circuit/System Description

The Inside Rearview Mirror (ISRVM) uses 2 magnetic field sensors for compass direction. One sensor is for north and south, the other is for east and west. The ISRVM supplies a signal and low reference to each sensor. As the vehicle travels with or against the Earth's magnetic pull, there will be a change in voltage on one or both sensors. As a result of the change in voltage, the ISRVM changes the heading on the compass display. The internal fault detection for the compass is handled by the ISRVM.

Reference Information**Schematic Reference**

- **Inside Rearview Mirror Schematics**
- **Instrument Cluster Schematics**

Connector End View Reference**Displays and Gages Connector End Views****Electrical Information Reference**

- **Circuit Testing**
- **Connector Repairs**
- **Testing for Intermittent Conditions and Poor Connections**
- **Wiring Repairs**

Scan Tool Reference**Scan Tool Data List****Circuit/System Testing**

1. Ignition ON, compass ON, verify that there is a compass reading on the display.
 - If the display is blank, replace the ISRVM.
 - If the display shows the letter C or CAL, perform the compass calibration procedure. Refer to **Compass Calibration and Magnetic Variance**.
2. Verify that the compass reading on the display is correct.
 - If not correct, perform the compass magnetic variation adjustment procedure. Refer to **Compass Calibration and Magnetic Variance**.
3. If the display is still incorrect, replace the ISRVM.

Repair Procedures

Perform the **Diagnostic Repair Verification** after completing the diagnostic procedure.

Control Module References for ISRVM replacement, setup and programming

MIRRORS - TEMPERATURE DISPLAY INACCURATE**Diagnostic Instructions**

- Perform the **Diagnostic System Check - Vehicle** prior to using this diagnostic procedure.
- Review **Strategy Based Diagnosis** for an overview of the diagnostic approach.
- **Diagnostic Procedure Instructions** provides an overview of each diagnostic category.

Circuit/System Description

The inside rear view mirror (ISRVM) applies 5 volts to the ambient air temperature sensor. The ambient air temperature sensor is a thermistor which varies in resistance as the temperature changes. As the resistance of the ambient air temperature sensor increases, the ISRVM senses a larger voltage drop across the sensor, indicating a lower temperature. As the resistance of the ambient air temperature sensor decreases, the ISRVM senses a smaller voltage drop across the sensor, indicating a higher temperature.

Diagnostic Aids

The following table will be used to measure the resistance of the sensor and compare it with the actual ambient temperature. The mirror temperature accuracy should be within 5 degrees of the actual temperature. The actual temperature should not be taken from a radio station, a sign displaying the temperature, etc. A temperature measuring tool such as a thermometer should be used. Some temperature measuring tools may be within 5 degrees of the actual temperature. Make sure to consult the manufacturer for the accuracy of the tool. This comparison can make the

2007 Hummer H3

2007 ACCESSORIES & EQUIPMENT Displays and Gages - H3

mirror seem off by 5-10 degrees of the actual temperature when it is not.

Ambient Air Temperature Sensor Resistance

°C	°F	Minimum Resistance K Ohms	Maximum Resistance K Ohms
-35	-31	234.81	250.59
-30	-22	171.69	182.31
-25	-13	126.82	133.99
-20	-4	94.63	99.49
-15	5	71.30	74.58
-10	14	54.21	56.43
-5	23	41.48	43.17
0	32	32.00	33.31
5	41	24.96	25.83
10	50	19.61	20.19
15	59	15.49	15.94
20	68	12.31	12.67
25	77	9.85	10.12
30	86	7.96	8.15
35	95	6.45	6.61
40	104	5.27	5.39
45	113	4.32	4.42
50	122	3.56	3.64
55	131	2.95	3.02
60	140	2.46	2.52

Reference Information

Schematic Reference

- [Inside Rearview Mirror Schematics](#)
- [Instrument Cluster Schematics](#)

Connector End View Reference

[Displays and Gages Connector End Views](#)

Electrical Information Reference

- Circuit Testing
- Connector Repairs
- Testing for Intermittent Conditions and Poor Connections
- Wiring Repairs

Scan Tool Reference

Scan Tool Data List

Circuit/System Testing

1. Ignition OFF, disconnect the harness connector at the ambient air temperature sensor. Install a signal generator and instrument panel tester between the signal circuit and the low reference circuit.
2. Ignition ON, vary the resistance on the signal generator from 2.5K to 230K. Verify that the temperature displayed on the ISRVM matches the ambient temperature resistance chart.
 - If the temperature displayed is incorrect, test the signal circuit and the low reference circuit for an open/high resistance. If the circuits test normal, replace the ISRVM.
3. If the temperature displayed is correct, replace the ambient air temperature sensor.

Repair Procedures

Perform the Diagnostic Repair Verification after completing the diagnostic procedure.

Control Module References for ISRVM replacement, setup and programming

MIRRORS - TEMPERATURE DISPLAYS SC OR OC

Diagnostic Instructions

- Perform the Diagnostic System Check - Vehicle prior to using this diagnostic procedure.
- Review Strategy Based Diagnosis for an overview of the diagnostic approach.
- Diagnostic Procedure Instructions provides an overview of each diagnostic category.

Circuit/System Description

The inside rearview mirror (ISRVM) applies 5 volts to the ambient air temperature sensor. The ambient air temperature sensor is a thermistor which varies in resistance as the temperature

2007 Hummer H3

2007 ACCESSORIES & EQUIPMENT Displays and Gages - H3

changes. As the resistance of the ambient air temperature sensor increases, the ISRVM senses a larger voltage drop across the sensor, indicating a lower temperature. As the resistance of the ambient air temperature sensor decreases, the ISRVM senses a smaller voltage drop across the sensor, indicating a higher temperature.

Diagnostic Aids

The following table will be used to measure the resistance of the sensor and compare it with the actual ambient temperature. The mirror's temperature accuracy should be within 5 degrees of the actual temperature. The actual temperature should not be taken from a radio station, a sign displaying the temperature, etc. A temperature measuring tool such as a thermometer should be used. Some temperature measuring tools may be within 5 degrees of the actual temperature. Make sure to consult the manufacturer for the accuracy of the tool. This comparison can make the mirror seem off by 5-10 degrees of the actual temperature when it is not.

Ambient Air Temperature Sensor Resistance

°C	°F	Minimum Resistance K Ohms	Maximum Resistance K Ohms
-35	-31	234.81	250.59
-30	-22	171.69	182.31
-25	-13	126.82	133.99
-20	-4	94.63	99.49
-15	5	71.30	74.58
-10	14	54.21	56.43
-5	23	41.48	43.17
0	32	32.00	33.31
5	41	24.96	25.83
10	50	19.61	20.19
15	59	15.49	15.94
20	68	12.31	12.67
25	77	9.85	10.12
30	86	7.96	8.15
35	95	6.45	6.61
40	104	5.27	5.39
45	113	4.32	4.42
50	122	3.56	3.64
55	131	2.95	3.02

2007 Hummer H3

2007 ACCESSORIES & EQUIPMENT Displays and Gages - H3

60

140

2.46

2.52

Reference Information

Schematic Reference

- Inside Rearview Mirror Schematics
- Instrument Cluster Schematics

Connector End View Reference

Displays and Gages Connector End Views

Electrical Information Reference

- Circuit Testing
- Connector Repairs
- Testing for Intermittent Conditions and Poor Connections
- Wiring Repairs

Scan Tool Reference

Scan Tool Data List

Circuit/System Testing

1. Ignition OFF, disconnect the ambient air temperature sensor.
2. Ignition OFF, test for less than 1 ohm of resistance between the low reference circuit and ground.
 - If greater than 1 ohm, test the ground circuit for an open/high resistance.
3. Ignition ON, verify that OC is displayed on the ISRVM display.
 - If OC is not displayed, test the signal circuit for a short to ground.
4. Ignition ON, install a 3-amp fused jumper wire between the signal circuit and ground. Verify that SC is displayed on the ISRVM display.
 - If SC is not displayed, test the signal circuit for an open/high resistance. If the circuit tests normal replace the ISRVM.
5. If the display is correct, replace the ambient air temperature sensor.

Repair Procedures

Perform the **Diagnostic Repair Verification** after completing the diagnostic procedure.

Control Module References for ISRVM replacement, setup and programming

ODOMETER TRIP/RESET SWITCH INOPERATIVE

Diagnostic Instructions

- Perform the **Diagnostic System Check - Vehicle** prior to using this diagnostic procedure.
- Review **Strategy Based Diagnosis** for an overview of the diagnostic approach.
- **Diagnostic Procedure Instructions** provides an overview of each diagnostic category.

Circuit/System Description

The instrument panel cluster (IPC) calculates the mileage based on the vehicle speed signal circuit from the powertrain control module (PCM). The PCM sends a class 2 serial data message to the IPC indicating the value of the odometer. The odometer will display 'error' if an internal IPC memory failure is detected or there is a class 2 communication fault. The odometer displays either miles or kilometers and the desired units can be accessed by pressing the trip/reset switch.

Reference Information

Schematic Reference

Instrument Cluster Schematics

Connector End View Reference

Displays and Gages Connector End Views

Electrical Information Reference

- **Circuit Testing**
- **Connector Repairs**
- **Testing for Intermittent Conditions and Poor Connections**
- **Wiring Repairs**

Scan Tool Reference

Scan Tool Data List

Circuit/System Testing

Ignition ON, press the trip reset button a few times to verify the odometer and trip odometer

- If the odometer display does not switch between odometer and trip odometer, replace IPC.

Repair Procedures

Perform the **Diagnostic Repair Verification** after completing the diagnostic procedure.

Control Module References for the IPC replacement, setup and programming

SPEEDOMETER AND/OR ODOMETER INACCURATE OR INOPERATIVE

Diagnostic Instructions

- Perform the **Diagnostic System Check - Vehicle** prior to using this diagnostic procedure.
- Review **Strategy Based Diagnosis** for an overview of the diagnostic approach.
- **Diagnostic Procedure Instructions** provides an overview of each diagnostic category.

Circuit/System Description

The instrument panel cluster (IPC) displays the vehicle speed based on the information from the powertrain control module (PCM). The PCM converts the data from the vehicle speed sensor to a 4000 pulses/mile signal. The PCM sends the vehicle speed information via class 2 serial data circuit to the IPC in order to display the vehicle speed and miles traveled.

Diagnostic Aids

Check for the following DTCs:

- **DTC B1000** , **DTC B1007** and **DTC B1009**
- **DTC U1000 and U1255** and **DTC U1001-U1254**

Reference Information

Schematic Reference

Instrument Cluster Schematics

Connector End View Reference

Displays and Gages Connector End Views

Electrical Information Reference

- **Circuit Testing**
- **Connector Repairs**
- **Testing for Intermittent Conditions and Poor Connections**
- **Wiring Repairs**

Scan Tool Reference

Scan Tool Data List

Circuit/System Testing

1. Ignition OFF, raise the vehicles drive wheels.
2. Engine ON, transmission in drive, verify the scan tool Vehicle Speed Sensor parameter matches the speedometer display.
 - If the Vehicle Speed Sensor parameter does not match the speedometer display, replace the IPC.
3. Verify that the odometer is operating properly.
 - If the odometer is not operating properly, replace the IPC.

Repair Procedures

Perform the **Diagnostic Repair Verification** after completing the diagnostic procedure.

Control Module References for IPC replacement, setup and programming

TACHOMETER INACCURATE OR INOPERATIVE

Diagnostic Instructions

- Perform the **Diagnostic System Check - Vehicle** prior to using this diagnostic procedure.
- Review **Strategy Based Diagnosis** for an overview of the diagnostic approach.
- **Diagnostic Procedure Instructions** provides an overview of each diagnostic category.

Circuit/System Description

The instrument panel cluster (IPC) displays the engine speed based on the information from the powertrain control module (PCM). The PCM converts the data from the engine speed sensor to a 2 pulses/engine revolution signal. The PCM sends the engine speed information via class 2 serial

data circuit to the IPC in order to display the engine speed.

Reference Information

Schematic Reference

Instrument Cluster Schematics

Connector End View Reference

Displays and Gages Connector End Views

Electrical Information Reference

- Circuit Testing
- Connector Repairs
- Testing for Intermittent Conditions and Poor Connections
- Wiring Repairs

Scan Tool Reference

Scan Tool Data List

Circuit/System Testing

Ignition ON, perform the tachometer gage sweep test with the scan tool.

- If the tachometer gage does not sweep from its low to high position, replace the IPC.

Repair Procedures

Perform the Diagnostic Repair Verification after completing the diagnostic procedure.

Control Module References for IPC replacement, setup and programming

REPAIR INSTRUCTIONS

AMBIENT AIR TEMPERATURE SENSOR REPLACEMENT

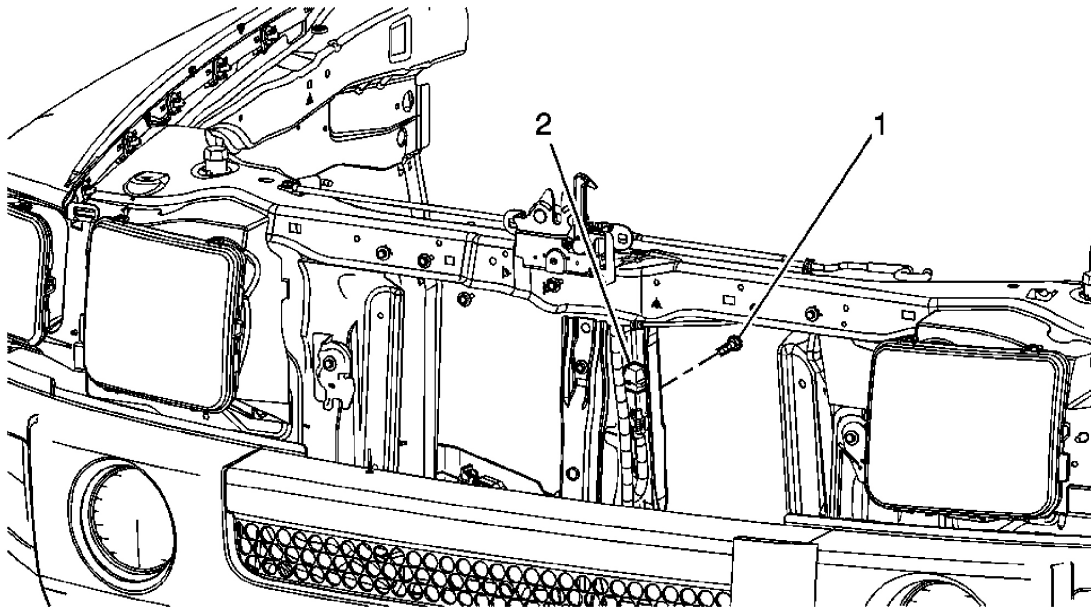

Fig. 9: Ambient Air Temperature Sensor Replacement
 Courtesy of GENERAL MOTORS CORP.

Ambient Air Temperature Sensor Replacement

Callout	Component Name
<p>NOTE: Refer to <u>Fastener Notice</u> .</p> <p>Fastener Tightening Specifications: Refer to <u>Fastener Tightening Specifications</u>. Preliminary Procedures: Remove the front grille. Refer to <u>Grille Replacement</u> .</p>	
1	Screw, Sensor Ambient Air Temperature Tighten: 10 N.m (89 lb in)
2	Sensor, Ambient Air Temperature

INSTRUMENT CLUSTER REPLACEMENT (LEFT HAND DRIVE)

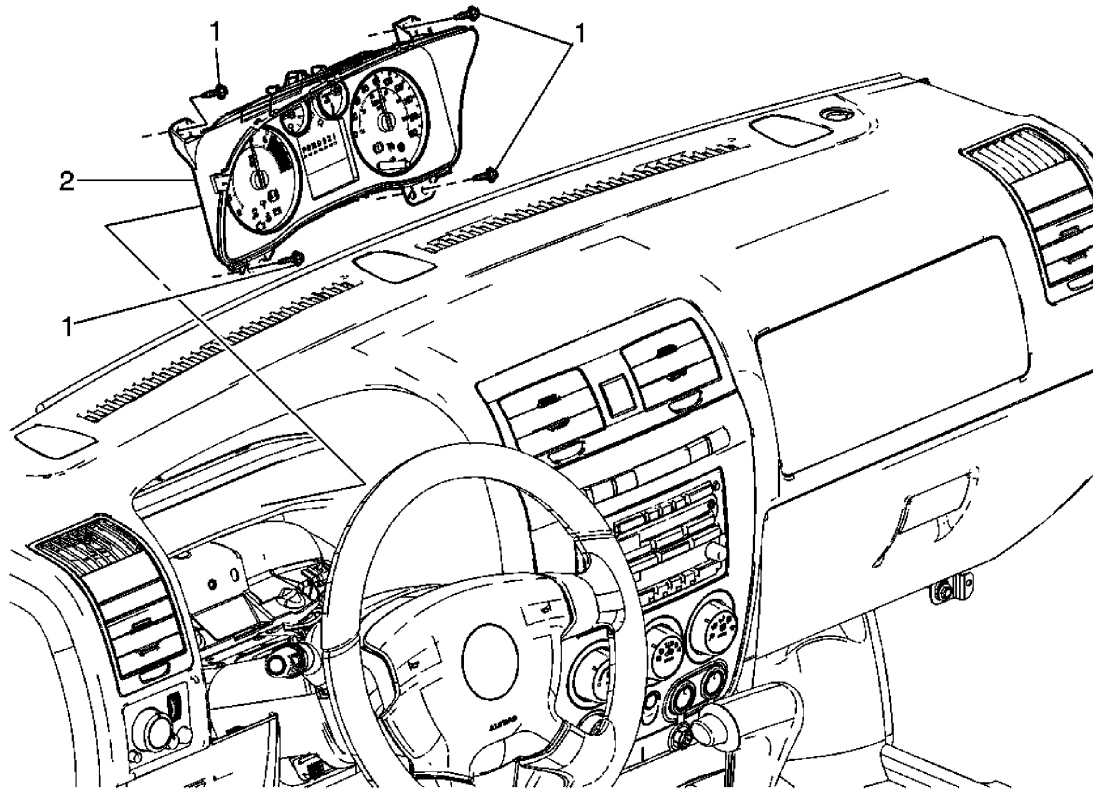

Fig. 10: Instrument Panel Cluster (IPC) Replacement
 Courtesy of GENERAL MOTORS CORP.

Instrument Cluster Replacement (Left Hand Drive)

Callout	Component Name
<p>Preliminary Procedure: Remove the instrument panel cluster trim plate. Refer to <u>Instrument Cluster Trim Panel Replacement (Left Hand Drive)</u> or <u>Instrument Cluster Trim Panel Replacement (Right Hand Drive)</u> .</p>	
<p>1</p>	<p>Instrument Panel Cluster Screw (Qty: 4)</p> <p>NOTE: Refer to <u>Fastener Notice</u> .</p> <p>Tighten: 2 N.m (18 lb in)</p>
<p>2</p>	<p>Instrument Panel Cluster Assembly</p> <p>Procedure</p>

1. Disconnect the electrical connector.
2. Reprogram the instrument cluster. Refer to **Control Module References** .

INSTRUMENT CLUSTER REPLACEMENT (RIGHT HAND DRIVE)

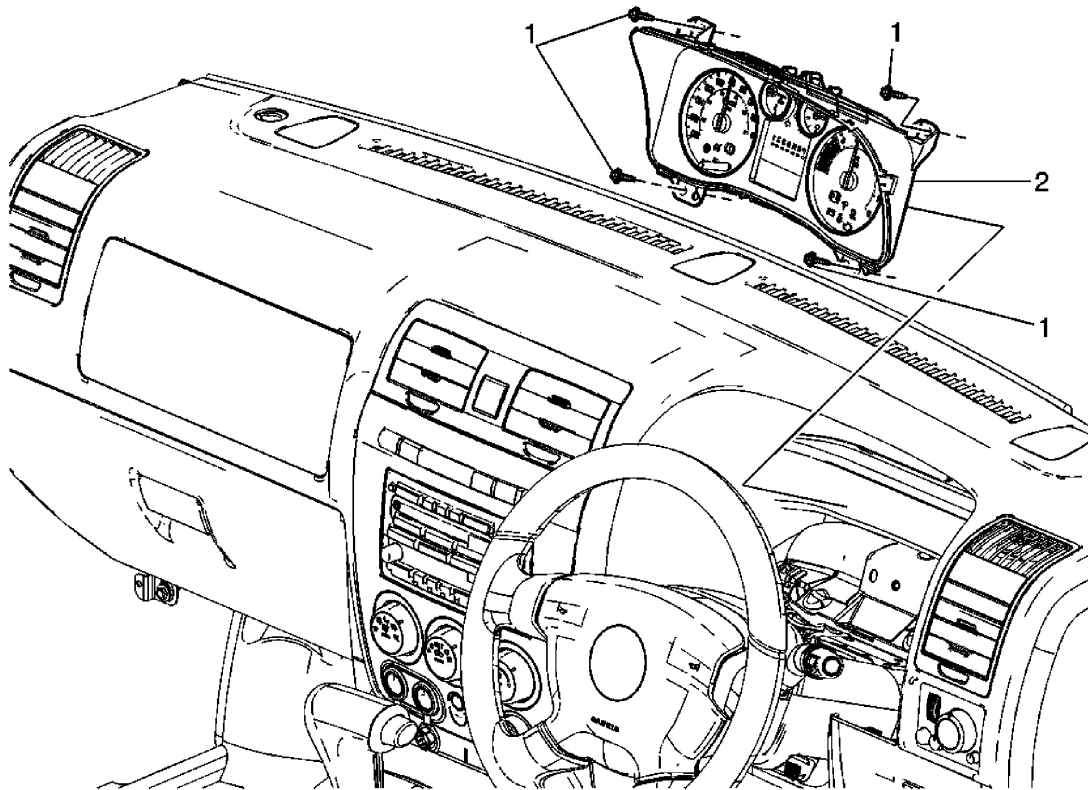

Fig. 11: Replacing Instrument Cluster (Right Hand Drive)
 Courtesy of GENERAL MOTORS CORP.

Instrument Cluster Replacement (Right Hand Drive)

Callout	Component Name
<p>Preliminary Procedure: Remove the instrument panel cluster trim plate. Refer to <u>Instrument Cluster Trim Panel Replacement (Left Hand Drive)</u> or <u>Instrument Cluster Trim Panel Replacement (Right Hand Drive)</u> .</p>	
<p>1</p>	<p>Instrument Panel Cluster Screw (Qty: 4)</p> <p>NOTE:</p>

	Refer to Fastener Notice .
	Tighten: 2 N.m (18 lb in)
2	Instrument Panel Cluster Assembly Procedure 1. Disconnect the electrical connector. 2. Reprogram the instrument cluster. Refer to Control Module References .

ACCESSORY SWITCH REPLACEMENT

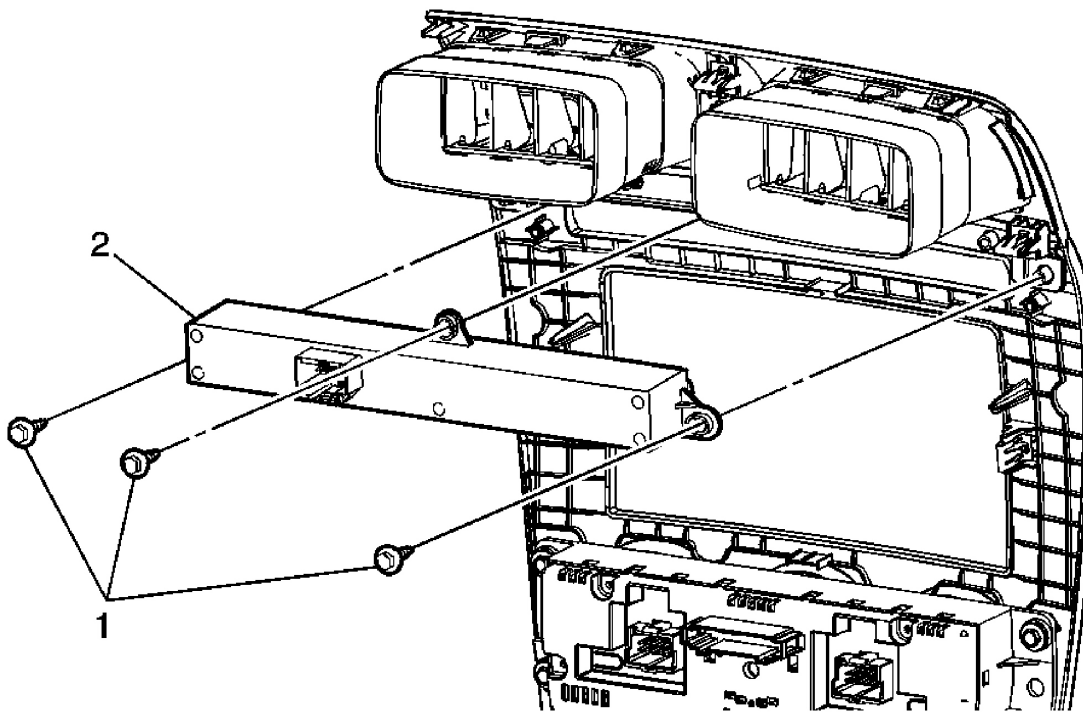

Fig. 12: Accessory Switch Replacement
Courtesy of GENERAL MOTORS CORP.

Accessory Switch Replacement

Callout	Component Name
Preliminary Procedure:	
Remove the instrument panel center trim plate. Refer to Instrument Panel Center Trim Panel Replacement (Left Hand Drive) or Instrument Panel Center Trim Panel	

2007 Hummer H3

2007 ACCESSORIES & EQUIPMENT Displays and Gages - H3

Replacement (Right Hand Drive) .

1	Instrument Panel Accessory Switch Screw (Qty: 3) NOTE: Refer to <u>Fastener Notice</u> . Tighten: 2 N.m (18 lb in)
2	Instrument Panel Accessory Switch Assembly

DESCRIPTION AND OPERATION

AUDIBLE WARNINGS DESCRIPTION AND OPERATION

The audible warnings alert the driver of a system concern or a critical vehicle condition. The radio generates the audible warnings through the left front speaker. The radio receives audible warning requests via the class 2 serial data line. If the radio receives multiple audible warning requests, the warning with the highest priority sounds first. On vehicles without a radio, the instrument panel cluster (IPC) will produce the chime. Either the radio or the IPC is the chime producer. The following lists the audible warning priority and the pulse rate:

1. Fast rate chime (200 pulses per minute)
2. Medium rate chime (150 pulses per minute)
3. Slow rate chime (50 pulses per minute)
4. Single chime

Door Ajar Warning

The chime producer activates the door ajar audible warning as requested by the body control module (BCM). The BCM sends a class 2 message to the chime producer indicating the chime frequency (medium rate) and duration (4 pulses). The door ajar warning sounds and the appropriate DOOR AJAR indicator illuminates in the driver information center (DIC) when the following occurs:

- The body control module (BCM) determines that a door, driver door, passenger door, left rear door, right rear door, is open and the signal circuit is low. The IPC receives a class 2 message from the BCM indicating the door ajar status.
- The vehicle is not in park. The IPC receives a class 2 message from the PCM indicating the gear position.
- The vehicle speed is greater than 8.05 km/h (5 MPH). The IPC uses the vehicle speed signal

circuit (4000 pulses/mile) from the PCM in order to calculate the vehicle speed.

Fasten Safety Belt Warning

The chime producer activates the fasten safety belt audible warning as requested by the BCM. The BCM sends a class 2 message to the chime producer indicating the chime frequency (slow rate) and duration (8 seconds). The fasten safety belt warning sounds and the fasten safety belt indicator illuminates when the following occurs:

- The ignition switch transitions to ON.
- The inflatable restraint sensing and diagnostic module (SDM) detects that the driver's seat belt is not buckled (signal is low). The IPC receives a class 2 message from the SDM indicating the drivers seat belt status.

If the seat belt is buckled when the ignition is turned ON, the chime will not sound. If the seat belt is buckled while the chime is sounding, the chime will stop. If the seat belt is unbuckled after the initial transition to ON, the chime will not sound.

Key-In-Ignition Warning

The chime producer activates the key-in-ignition audible warning as requested by the BCM. The BCM sends a class 2 message to the chime producer indicating the chime frequency (medium rate) and duration (continuous). The key-in-ignition warning sounds when the following occurs:

- The ignition switch is OFF.
- The body control module (BCM) determines that the driver's door is open and the signal circuit is low. The IPC receives a class 2 message from the BCM indicating the door ajar status.
- The BCM determines that the key-in-ignition switch is closed and the signal circuit is low. The IPC receives a class 2 message from the BCM indicating the key-in-ignition status.

Lights On Warning

The chime producer activates the lights on warning as requested by the body control module (BCM). The BCM sends a class 2 message to the chime producer indicating the chime frequency (fast rate) and duration (continuous). The lights on warning sounds when the following occurs:

- The ignition is OFF.
- The BCM determines that the drivers door is open and the signal circuit is low.
- The BCM determines that the headlamp switch is in the park or head position.

Park Brake Warning

The chime producer activates the park brake active audible warning as requested by the BCM. The BCM sends a class 2 message to the chime producer indicating the chime frequency (fast rate) and duration (4 pulses).

- The body control module (BCM) determines that the park brake is applied.
- The vehicle is not in park. The IPC receives a class 2 message from the powertrain control module (PCM) indicating the gear position.
- The vehicle speed is greater than 8.05 km/h (5 mph). The IPC uses the vehicle speed signal circuit (4000 pulses/mile) from the powertrain control module (PCM) in order to calculate the vehicle speed.

Additional Warnings

The following warnings have an associated instrument panel cluster (IPC) indicator or driver information center (DIC) indicator:

- Check Oil Level

The chime producer activates the audible warning as requested by the BCM. The BCM sends a class 2 message to the chime producer indicating the chime frequency (medium rate) and duration (4 pulses).

- Low Fuel

The chime producer activates the audible warning as requested by the BCM. The BCM sends a class 2 message to the chime producer indicating the chime frequency (medium rate) and duration (4 pulses).

- Oil Pressure Low Stop Engine

The chime producer activates the audible warning as requested by the BCM. The BCM sends a class 2 message to the chime producer indicating the chime frequency (fast rate) and duration (continuous).

- Reduced Engine Power

The chime producer activates the audible warning as requested by the BCM. The BCM sends a class 2 message to the chime producer indicating the chime frequency (medium rate) and (4 pulses) duration.

- Trans Hot Idle Engine

The chime producer activates the audible warning as requested by the BCM. The BCM sends a class 2 message to the chime producer indicating the chime frequency (fast rate) and duration (continuous).

- Turn Signal On

The chime producer activates the audible warning as requested by the BCM. The BCM sends a class 2 message to the chime producer indicating the chime frequency (fast rate) and duration (1 pulse).

Refer to **Indicator/Warning Message Description and Operation**.

COMPASS CALIBRATION AND MAGNETIC VARIANCE

Compass Calibration

Before calibrating the compass, drive the vehicle to an open area that is magnetically clean or free of large metallic objects such as high tension power lines or large steel buildings. Verify there are no magnetized roof antennas, magnets on or hanging from the mirror or any other magnetized objects on the inside or outside of the vehicle close to the mirror.

1. Start the engine.

IMPORTANT: Before calibrating the compass, make sure the mirror has the correct zone number. Refer to Compass Magnetic Variation Adjustment.

2. Press and hold the switch for the compass, which may be depicted as compass/temperature or COMP, depending on the type of mirror on the vehicle, until the letter "C" is displayed.
3. Drive the vehicle in circles at a speed of less than 8 km/h (5 mph) until the "C" is replaced by a proper vehicle heading. The calibration procedure is now complete.

Compass Magnetic Variation Adjustment

Magnetic variation adjustments are required when the compass displays a constant error in heading. Variation is the difference between magnetic north and true north due to geographical location.

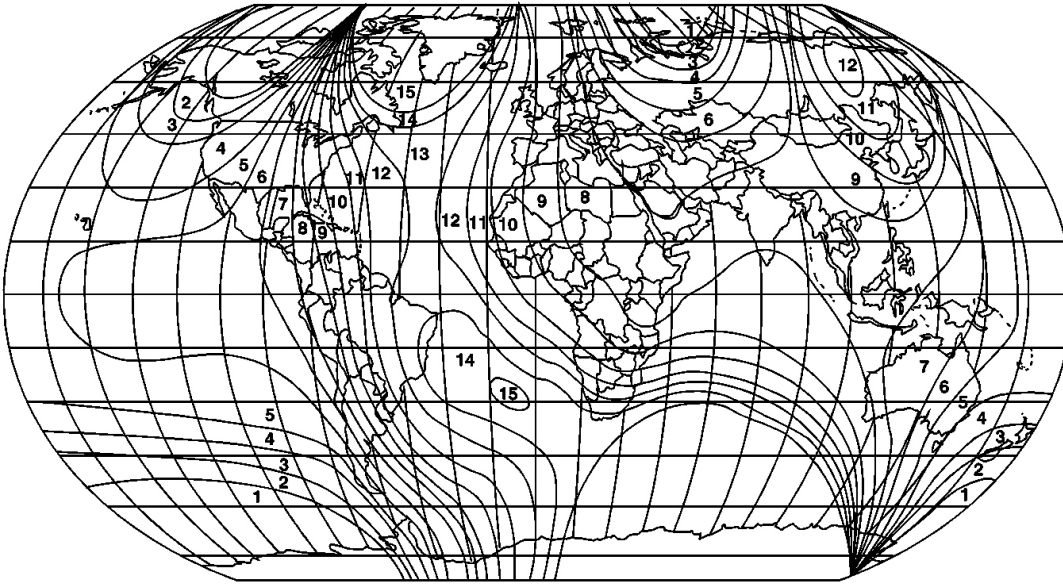

Fig. 13: World Magnetic Variation Map
Courtesy of GENERAL MOTORS CORP.

1. Locate your current geographic location on the World Magnetic Variation Map.
2. Turn ON the ignition, with the engine OFF.
3. Press and hold the switch for the compass, which may be depicted as compass/temperature or COMP, depending on the type of mirror on the vehicle, until a zone number appears on the compass display.
4. Release and press the switch again until the desired zone number appears.
5. Release and wait 4 seconds. The display will return to a compass heading. The variance procedure is now complete.
6. Calibrate the compass. Refer to **Compass Calibration** mentioned above.

DOOR AJAR INDICATOR DESCRIPTION AND OPERATION

Door Ajar Indicator

The instrument panel cluster (IPC) illuminates the door ajar indicator when the body control module (BCM) detects any of the 4 vehicle doors is open. The IPC receives a class 2 message from the BCM requesting illumination. The IPC sends a class 2 message to the radio in order to activate an audible warning.

DRIVER INFORMATION CENTER (DIC) DESCRIPTION AND OPERATION

2007 Hummer H3

2007 ACCESSORIES & EQUIPMENT Displays and Gages - H3

Driver Information Center (DIC)

The driver information center (DIC) consists of a double line 14 character display placed in the lower center area of the instrument panel cluster (IPC). The DIC will display vehicle information, configuration and warning parameters to the driver.

The display parameters are cycled, changed and acknowledged using a control stem. Pressing the stem for 1 second will display the DIC options. Pressing the stem for more than 2 seconds will select an option.

DIC Displays

The driver information center (DIC) parameters are displayed by order of priority as follows (from highest to lowest):

- Service Diagnostics
- Feature Programming
- Driver Warnings
- Vehicle Information

Vehicle Information

Vehicle information provides feedback to the driver on vehicle performance, mileage, maintenance or related information.

Vehicle information can only be displayed with the engine OFF and the ignition in the ON position.

When the English/Metric status changes, any applicable vehicle information data values will also change.

DIC Trip Information/Reset Capabilities

The available DIC Trip Information and reset capabilities are as follows:

- Odometer-Cannot be reset
- Trip Odometer-Can be reset

Odometer

The odometer is capable of displaying values from 0-999,999 KM or MI. If the ignition is in the OFF or UNLOCK/ACC position, the odometer can be displayed by pressing the trip/reset switch.

The odometer will remain displayed for 5 seconds.

Trip Odometers

The trip odometer is capable of displaying values from 0-9999.9 KM or MI.

When the maximum value is reached, the trip odometer will roll over to 0.0.

Holding the control stem for greater than 4 seconds while the trip odometer is displayed will reset the displayed trip odometer to 0.0 upon release of the stem. The trip odometer will remain displayed after being reset.

Engine Oil Life

Engine Oil Life percentage values are based on class 2 messages to the instrument panel cluster (IPC). The IPC requests this value when Engine Oil Life is selected on the DIC.

Engine Oil Life is capable of displaying values from 0 to 100%.

Pressing the control stem for longer than 2 seconds while Engine Oil Life is displayed on the DIC will reset the value to 100%. An audible warning will sound confirming that the system has been reset.

Display appears as OIL LIFE: XXX%.

Display Language

The driver information center (DIC) is capable of displaying messages in more than one language. The DIC language selection procedure is as follows:

1. With the engine OFF, turn the key to ON, but do not start the engine.
2. Close all doors so the DOORS message does not display in the DIC.
3. Momentarily press and release the trip reset stem until the current language is displayed: English, French or Spanish.
4. To select a different language, press and hold the trip reset stem until the next language appears.
5. Repeat Step 4 until the desired language is displayed. Once the desired language is shown on the DIC display, the language is set.
6. To exit language selection, momentarily press and release the trip stem. All DIC messages will now display in the language selected.

Feature Programming

Refer to **Personalization Description and Operation** .

Driver Warnings

For the list of Driver Warnings, refer to **Indicator/Warning Message Description and Operation**.

INDICATOR/WARNING MESSAGE DESCRIPTION AND OPERATION

Indicators

Symbol	Description
	ABS: Refer to <u>ABS Description and Operation</u>
	Air Bag: Refer to <u>SIR System Description and Operation</u>

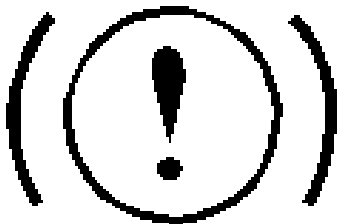

Brake: Refer to **Brake Warning System**
Description and Operation

2007 Hummer H3

2007 ACCESSORIES & EQUIPMENT Displays and Gages - H3

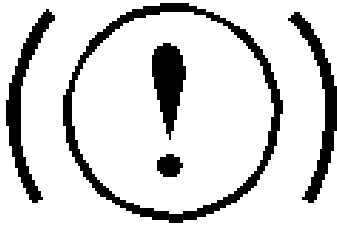

BRAKE (U.S.)

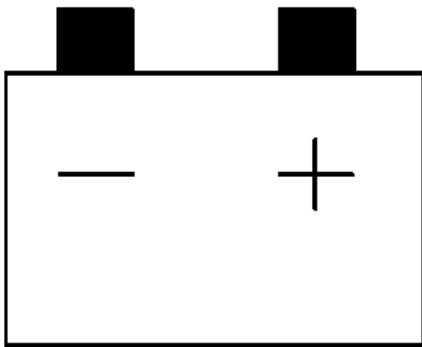

Charge: Refer to **Charging System**
Description and Operation

CRUISE: Refer to **Cruise Control**
Description and Operation

2007 Hummer H3

2007 ACCESSORIES & EQUIPMENT Displays and Gages - H3

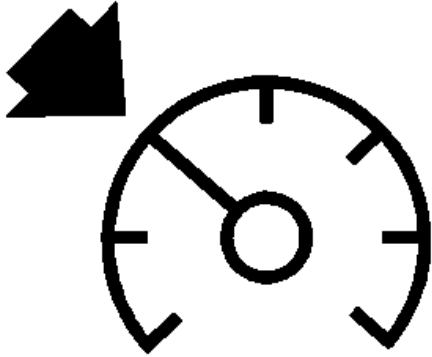

(Canada)
CRUISE (U.S.)



Fasten Safety Belt: Refer to **Seat Belt System Description and Operation**

2007 Hummer H3

2007 ACCESSORIES & EQUIPMENT Displays and Gages - H3



Fasten Passenger Seat Belts: Refer to Seat Belt System Description and Operation

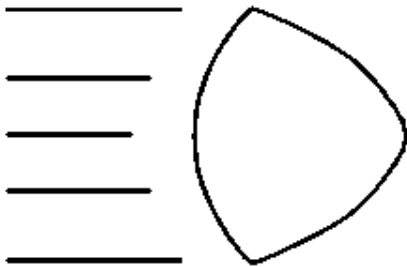

High Beam: Refer to Exterior Lighting Systems Description and Operation

Passenger Air Bag Off: Refer to SIR System Description and Operation

2007 Hummer H3

2007 ACCESSORIES & EQUIPMENT Displays and Gages - H3



Passenger Air Bag On: Refer to **SIR System Description and Operation**

SECURITY: Refer to **Content Theft Deterrent (CTD) Description and Operation**

2007 Hummer H3

2007 ACCESSORIES & EQUIPMENT Displays and Gages - H3

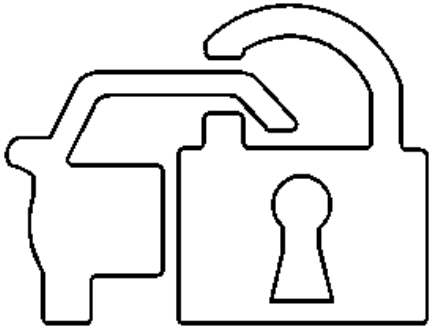

(Canada)
SECURITY (U.S.)

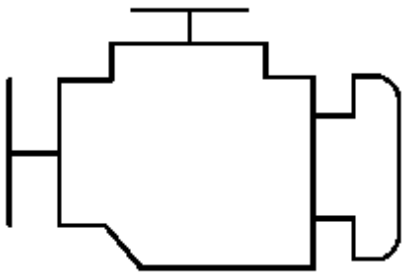

(Canada)
SERVICE ENGINE SOON (U.S.)

Refer to **Powertrain Control Module Description**

Tire Pressure Monitor: Refer to **Tire Pressure Monitor Description and Operation**

2007 Hummer H3

2007 ACCESSORIES & EQUIPMENT Displays and Gages - H3

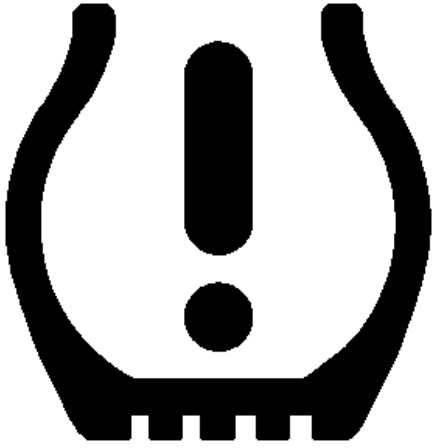

Turn Signals: Refer to Exterior Lighting Systems Description and Operation

Upshift Indicator: Refer to Indicator/Warning Message Description and Operation

2007 Hummer H3

2007 ACCESSORIES & EQUIPMENT Displays and Gages - H3

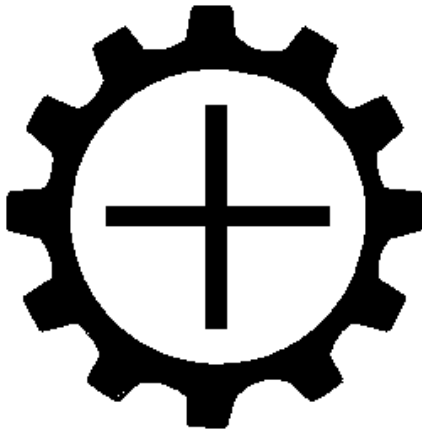
**DIC Warning Messages**

Symbol	Description
ABS	Refer to <u>ABS Description and Operation</u>
A/C OFF	Refer to <u>Cooling System Description and Operation</u>
BATTERY	Refer to <u>Charging System Description and Operation</u>
BRAKE FLUID	Refer to <u>Brake Warning System Description and Operation</u>
BRAKE SYSTEM	Refer to <u>Brake Warning System Description and Operation</u>
CARGO LAMP	Refer to <u>Interior Lighting Systems Description and Operation</u>
CHANGE OIL	Refer to Indicator/Warning Message Description and Operation
CHECK FUEL CAP	Refer to Indicator/Warning Message Description and Operation
DOORS	Refer to <u>Door Ajar Indicator Description and Operation</u>
DOMELAMP	Refer to <u>Interior Lighting Systems Description and Operation</u>

2007 Hummer H3

2007 ACCESSORIES & EQUIPMENT Displays and Gages - H3

ENG HOT	Refer to <u>Cooling System Description and Operation</u>
LO FUEL	Refer to Indicator/Warning Message Description and Operation
LOW TRAC	Refer to <u>ABS Description and Operation</u>
MAP LAMP	Refer to <u>Interior Lighting Systems Description and Operation</u>
OIL	Refer to Indicator/Warning Message Description and Operation
OIL LIFE	Refer to Indicator/Warning Message Description and Operation
PARK BRAKE	Refer to <u>Park Brake System Description and Operation</u>
REDUCED POWER	Refer to <u>Powertrain Control Module Description</u>
SERV 4WD	Refer to <u>Transfer Case Description and Operation</u>
SERV VEH	Refer to <u>Powertrain Control Module Description</u>
SERVICE TRACTION	Refer to <u>ABS Description and Operation</u>
TRAC OFF	Refer to <u>ABS Description and Operation</u>

CHANGE OIL

The instrument panel cluster (IPC) illuminates the CHANGE OIL indicator when the powertrain control module (PCM) determines that the engine oil should be changed. The IPC receives a class 2 message from the PCM indicating the remaining oil life percent. Once the oil is changed, perform the engine oil monitor reset procedure in order to clear the Change Engine Oil indicator. Refer to **GM Oil Life System Resetting** .

CHECK FUEL CAP

The IPC illuminates the CHECK FUEL CAP message in the driver information center (DIC) when the PCM detects a low fuel pressure condition. The IPC receives a class 2 message from the PCM requesting illumination.

LO FUEL

The IPC illuminates the LO FUEL message in the DIC when the IPC detects that the fuel level is

less than a pre-determined value. The IPC receives a class 2 message from the PCM indicating fuel level percent.

OIL

The IPC illuminates the OIL message in the DIC when the PCM detects a low oil pressure condition with the signal circuit low. The IPC receives a class 2 message from the PCM requesting illumination.

OIL LIFE

The IPC illuminates the OIL LIFE message when the PCM determines that the engine oil should be changed. The IPC receives a class 2 message from the PCM indicating the remaining oil life percent.

UPSHIFT INDICATOR

The IPC illuminates the UPSHIFT INDICATOR when the PCM determines that the vehicle should be shifted to the next higher gear. The IPC receives a class 2 message from the PCM requesting illumination.

INSTRUMENT CLUSTER DESCRIPTION AND OPERATION**Displays Test**

Certain instrument panel cluster (IPC) features are tested when the ignition is turned on in order to verify the features are working properly. The following indicators illuminate for 5 seconds:

- The Antilock Brake System (ABS) indicator
- The brake indicator
- The park brake indicator
- The SECURITY indicator
- The upshift indicator
- All gages sweep to their minimum physical position and then to their actual physical position.

The following indicators illuminate for the specified times:

- The AIR BAG indicator flashes 7 times.
- The seat belt indicator illuminates for 20 seconds followed by 55 seconds of flashing with the drivers seat belt unfastened, or, the seat belt indicator will illuminate for 8 seconds with

the drivers seat belt fastened.

- All message center segments illuminate briefly.

Indicators and Warning Messages

Refer to **Indicator/Warning Message Description and Operation**.

Engine Coolant Temperature Gage

The instrument panel cluster (IPC) displays the engine coolant temperature as determined by the powertrain control module (PCM). The IPC receives a class 2 message from the PCM indicating the engine coolant temperature. The engine coolant temperature gage defaults to 100°F (40°C) or below if:

- The PCM detects a malfunction in the engine coolant temperature sensor circuit.
- The IPC detects a loss of class 2 communications with the PCM.

Engine Oil Pressure Gage

The instrument panel cluster (IPC) displays the engine oil pressure as determined by the powertrain control module (PCM). The IPC receives a class 2 message from the PCM indicating the engine oil pressure. The engine oil pressure gage defaults to 0 psi (0 kPa) or below if:

- The PCM detects a malfunction in the engine oil pressure (EOP) sensor circuit.
- The IPC detects a loss of class 2 communications with the PCM.

Fuel Gage

The instrument panel cluster (IPC) displays the fuel level as determined by the powertrain control module (PCM). The IPC receives a class 2 message from the PCM indicating the fuel level percent. The fuel gage defaults to empty if:

- The PCM detects a malfunction in the fuel level sensor circuit.
- The IPC detects a loss of class 2 communications with the PCM.

Odometer

The base instrument panel cluster (IPC) contains a season odometer and a trip odometer. Momentarily press the trip/reset switch on the IPC in order to toggle between the season odometer and the trip odometer. Press the trip/reset switch for greater than 2 seconds, while the trip odometer is displayed, in order to reset the trip odometer.

The body control module (BCM) calculates the mileage based on the vehicle speed signal circuit from the powertrain control module (PCM). The BCM then sends a class 2 message to the IPC indicating the value of the odometer. The odometer will display 'error' if an internal BCM memory failure is detected.

PRND321 Display

The instrument panel cluster (IPC) displays the selected gear position as determined by the powertrain control module (PCM). The IPC receives a class 2 message from the PCM indicating the gear position. The PRND321 display blanks if:

- The PCM detects a malfunction in the transmission range switch circuit.
- The IPC detects a loss of class 2 communications with the PCM.

Speedometer

The instrument panel cluster (IPC) displays the vehicle speed based on the information from the powertrain control module (PCM). The PCM converts the data from the vehicle speed sensor to a 4000 pulses/mile signal. The IPC receives a class 2 message from the PCM indicating the vehicle speed.

Tachometer

The instrument panel cluster (IPC) displays the engine speed based on the information from the powertrain control module (PCM). The PCM converts the data from the engine speed sensor to a 2 pulses/engine revolution signal. The IPC receives a class 2 message from the PCM indicating the engine speed.

Voltmeter

The instrument panel cluster (IPC) displays the vehicle voltage based on the information from the body control module (BCM). The IPC uses class 2 serial data information from the BCM to provide a voltage level indication on the voltmeter.